

IGNITION COIL CATALOG

2026

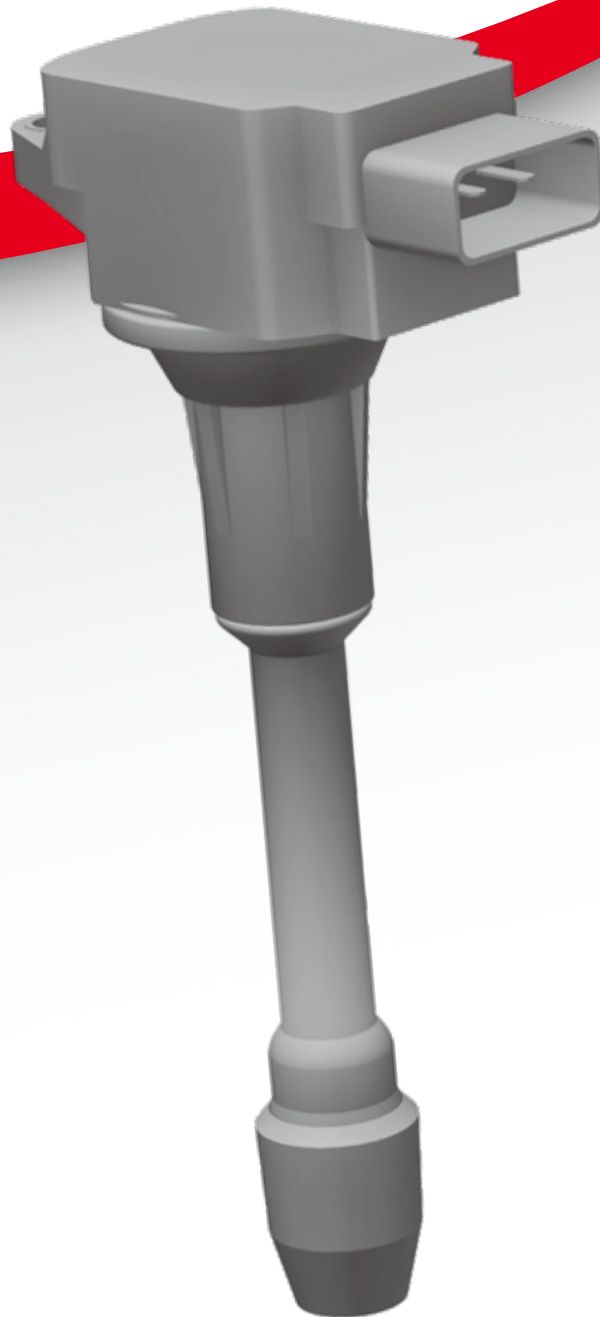

目 次

1. カタログ案内

ご注文の際は必ずご一読のうえ、本カタログをご利用ください。

2. カーメーカー、車種別 一覧表

・ トヨタ	TOYOTA	10 ~	42
・ 日産	NISSAN	43 ~	54
・ ホンダ	HONDA	55 ~	66
・ マツダ	MAZDA	67 ~	72
・ スバル	SUBARU	73 ~	78
・ 三菱	MITSUBISHI	79 ~	84
・ スズキ	SUZUKI	85 ~	90
・ ダイハツ	DAIHATSU	91 ~	99
・ いすゞ	ISUZU	100	

3. 品番対照表

・ 純正品番	↔ Astemo品番	101 ~	105
・ Astemo品番	↔ 純正品番	106 ~	110

本カタログは、エンジンマネジメントシステム製品を交換する際の参考資料としてご使用ください。

ご使用にあたっては、交換部品を間違えないよう、純正品番、適合車種などをご確認のうえ、ご注文いただきますようお願いいたします。

該当する品番がわからない場合は、弊社窓口までお問い合わせください。

《 ご案内 》

本カタログは2024年版カタログに新品番の追加など、誤記訂正も含め編集しました。
今後のご注文は、2026年版カタログをご利用ください。
また、混乱が生じないためにも、以前のカタログは廃却くださるようお願いいたします。

*本カタログの記載内容は2025年9月時点調査のものです。
記載内容は予告なく変更する場合があります。あらかじめご了承ください。

1. 用語の説明

記号	記号意味
除く (x x x)	() 内の x x x を除く
含む (x x x)	() 内の x x x を含む
EngineNo	エンジン番号
フルム No. X X ~ X X	車台番号
Hybrid	ハイブリッド車
PHV	プラグインハイブリッド車
AT	オートマチックトランスミッション
MT	マニュアルトランスミッション
CVT	無段変速式トランスミッション
DOHC	ダブル・オーバーヘッド・カムシャフト/ツインカム
SOHC	シングル・オーバーヘッド・カムシャフト
DI,GDI	直噴エンジン
2WD	二輪駆動
4WD	四輪駆動
RH	右ハンドル車
LH	左ハンドル車
FF	フロントエンジン・フロントドライブ
FR	フロントエンジン・リアドライブ
ECI,EGI,EFI,EPI,PFI	電子制御噴射装置
MPI	マルチポイントインジェクション
LPG	液化石油ガス車
CNG	天然ガス車
TURBO	ターボチャージャー
●	生産終了品

2. 収録順

- (1) 車両の収録順は、車名の数字・英字・カナの昇順となっています。
- (2) 製品設定がない車種、車両型式については記載していません。

交換作業をはじめる前にお読みください。

安全上のご注意

- 本製品の交換作業は、各車両の整備マニュアルに従い、自動車整備の有資格者が行ってください。誤った交換作業を行うと、事故や火災などの原因となります。
- 本来の使用目的以外では使用しないでください。使用目的以外の用途に使用すると、事故や火災などの原因となります。

警 告

- 落下など強い衝撃を受けた部品は使用しないでください。
- 本カタログの適合車種（年式、指定品番）以外には、使用しないでください。
※取付前にはカタログで品番の確認を行ってください。
- 換気のよい火気のない場所で、消火器をそばに置いて作業してください。火気のある場所で作業すると、火災の原因となります。
- 取り付け後、エンジンを始動し回転を上げて、燃料の漏れがないことを確認してください。燃料漏れがあると、事故や火災などの原因となります。

注 意

- 点検・整備にあたっては車両の取扱説明書や整備要領書に従ってください。
- 部品交換や点検整備の際は保護メガネや手袋などの着用、および粉塵対策を行ってください。

イグニッションコイルとは

点火プラグで火花放電させるための高電圧を発生する装置です

イグニッションコイルは、巻数が異なる一次コイルと二次コイルから構成されています。一次コイルに流れている電流を遮断すると、誘導現象によって二次コイルに高電圧が発生します。

従来はイグニッションコイルで発生させた電圧をディストリビューターによって各気筒の点火プラグに配電していましたが、最近ではディストリビューターを持たず、各気筒の点火プラグ上に配置された専用のコイルにて行うダイレクトイグニッション方式が主流になっています。

電子制御システム構成例

ダイレクトイグニッション方式製品例

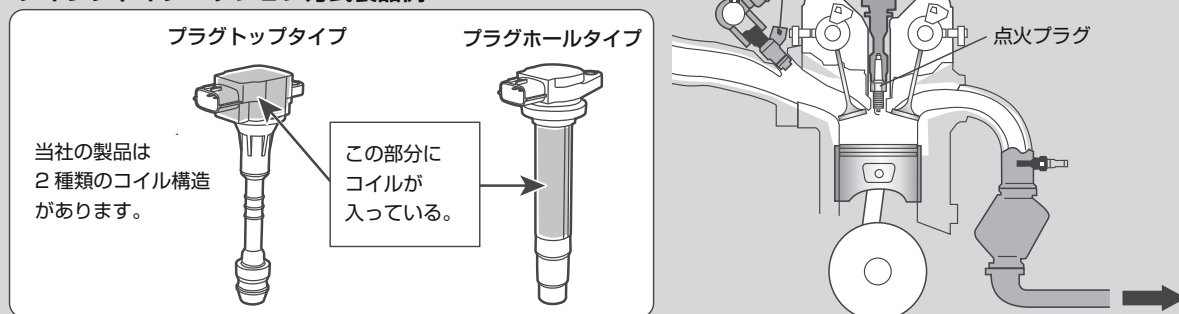

主な不具合症状と点検方法

不具合症状としては

- 加速時に回転が上がらなかつたり、息継ぎしたりする。
- アイドリングが不安定になったり、止まったりする。
- バッテリーやスターターモーターが正常なのにエンジンがかかりにくい。

などの症状が現れます。

点検方法としては、イグニッションコイルの端子間の抵抗を測定し、断線またはショートしていないかを確認する方法があります。

カーメーカーによって点検方法は異なりますので、各車両の整備マニュアルをご確認ください。

イグニッションコイルの寿命は、エンジンルーム内の環境と他の二次系部品の状態や整備での扱われ方で大きく差が生じます。

断線またはショートしていなくても、不具合症状が断続的に生じたり改善しない場合は、イグニッションコイルの交換をおすすめします。

イグニッションコイル交換時のお願い

お客さまの大切なお車を長くご使用いただくために

- 全気筒交換をおすすめします。
不調が発生している気筒以外のイグニッションコイルも劣化している可能性があります。
- スパークプラグも同時交換をおすすめします。
スパークプラグの電極消耗が大きいとスパークの高電圧により、イグニッションコイルの作動負荷が高まり寿命が短くなります。

車名索引

トヨタ TOYOTA	ページ
86	10
bB	10
C-HR	10
FJクルーザー	10
GRカローラ	10
GRヤリス クロス	10
iQ	10
LEXUS CT	10
LEXUS ES300	10
LEXUS GS200t	10
LEXUS GS250	11
LEXUS GS300	11
LEXUS GS350	11
LEXUS GS450	11
LEXUS GS F	11
LEXUS GX550	11
LEXUS HS250	11
LEXUS IS200t	11
LEXUS IS250	11~12
LEXUS IS300	12
LEXUS IS350	12
LEXUS IS500	12
LEXUS IS F	12
LEXUS LBX	12
LEXUS LC500/500h	12
LEXUS LC500/500h(クーペ)	12
LEXUS LM350h	12
LEXUS LM500h	12
LEXUS LS460	13
LEXUS LS500/500h	13
LEXUS LS600	13
LEXUS LX570	13
LEXUS LX600	13
LEXUS NX200t	13
LEXUS NX250	13
LEXUS NX300	13
LEXUS NX300h	13
LEXUS NX350	13
LEXUS NX350h	13~14
LEXUS NX450h+	14
LEXUS RC200t	14
LEXUS RC300	14
LEXUS RC300h	14
LEXUS RC350	14
LEXUS RC F	14
LEXUS RX	14
LEXUS RX200t	14
LEXUS RX300	15
LEXUS RX350	15
LEXUS RX350h	15
LEXUS RX450h	15
LEXUS RX450h+	15

トヨタ TOYOTA	ページ
LEXUS RX500h	15
LEXUS UX200	15
LEXUS UX250h	16
LEXUS UX300e	16
LEXUS UX300h	16
MR2	16
MR-S	16
RAV4	16
RAV4 L/J	16~17
RAV4 PHV	17
WILL Vi	17
WILL VS	17
WILL サイファ	17
アイシス	17
アクア	17
アベンシス	17
アリオン/プレミオ	18
アリスト	18
アルテッツァ	18
アルテッツァ ジータ	18
アルファード	18~19
アレックス	19
イスト	19
イプサム	19
ウィッシュ	19
ウインダム	19
ヴァンガード	20
ヴィッツ	20
ヴィッツ GRMN	20
ヴィッツ ハイブリッド	20
ヴェルファイア	20~21
ヴェロッサ	21
ヴォクシー	21
ヴォルツ	21
エスクァイア	21
エスティマ	21~22
エスティマ T/L	22
オリジン	22
オーバ	22
オーリス	22
カムリ	22~23
カムリ グラシア	23
カムリ ハイブリッド	23
カリーナ	23
カリーナ ED	23
カルディナ	23~24
カレン	24
カローラ	24~25
カローラ FX	25
カローラ アクシオ	25
カローラ クロス	25
カローラ スパシオ	25

車名索引

トヨタ TOYOTA	ページ
カローラ スポーツ	25
カローラ セレス	25
カローラ ツーリング	26
カローラ フィールダー	26
カローラ ランクス	26
カローラ ルミオン	26
カローラ レビン	26
ガイア	26~27
キャミ	27
クイックデリバリー	27
クラウン エステート	27
クラウン コンフォート	27
クラウン マジェスタ	27
クラウン パトロールカー	27
クラウン/クラウン アスリート	27~28
クラウン/クラウン ハイブリッド	28
クルーガー L/V	28~29
クレスト	29
グランビア	29
コロナ	29
コロナ プレミオ	29
コペン	29
コンフォート	29
サイ	29
サクシード	29~30
サイノス	30
シエンタ	30
スープラ	30
スターレット	30
スパーキー	30
スプリンター	31
スプリンター カリブ	31
スプリンター トレノ	31
スプリンター マリノ	31
スペイド	31
セブター	31
セラ	31
セリカ	31
セルシオ	32
センチュリー	32
ソアラ	32
ターセル	32
タンク/ルーミー	32
ダイナ/トヨエース	32~33
チェイサー	33
ツーリングハイエース	33
デュエット	33
ナディア	33
ノア	34
ハイエース	34
ハイラックス	35
ハイラックスサーフ	35

トヨタ TOYOTA	ページ
ハリアー/ハリアー ハイブリッド	35~36
パッソ	36
ビスタ	36
ビスタ アルディオ	36
ピクシス	36
ピクシス エポック	37
ピクシス ジョイ	37
ピクシス メガ	37
ピクシス スペース	37
ファンカーゴ	37
ブレイド	37
ブラッツ	37
プリウス	38
プリウスPHV	38
プリウスα	38
プログレス	38
プロナード	38
プロボックス	38
ベルタ	39
ポルテ	39
マークII	39
マークII クオリス	39
マークII ブリット	39
マークX	40
マークX ジオ	40
ライズ	40
ライトエース/タウンエース/マスターエース	40
ラウム	40
ラクティス	41
ラッシュ	41
ランドクルーザー	41
ランドクルーザー プラド	41
レジアス	41
レジアスエース	41~42
ヤリス	42
ヤリス クロス	42
日産 NISSAN	ページ
AD	43
AD エキスパート	43
GT-R	43
NT100 クリッパー	43
NV100 クリッパー/リオ	43
NV200 バネット	43
NV350 キャラバン	43
X-TRAIL	44
アトラス/コンドル	44
アベニール	44
インフィニティ Q45	44
ウイングロード	44
エキスパート	44~45
エルグランド	45
オッティ	45

車名索引

日産 NISSAN	ページ
キャラバン	45
キューブ	45
キューブ キュービック	45
キックス	45
クリッパー	46
クリッパー リオ	46
サニー	46
サファリ	46
シーマ	46
シルビア	46
シルフィ	47
ジューク	47
スカイライン/スカイラインGT-R	47~48
スカイライン クロスオーバー	48
ステージア	48
セドリック/グロリア	48~49
セフィーロ	49
セレナ	49~50
ティアナ	50
ティーダ	50
ティーダ ラティオ	50
ティーノ	50
デイズ	50
デイズルークス	50
デュアリス	50
ノート	51
パサラ	51
パネット	51
パネット バン/トラック	51
ピノ	51
フーガ	51
フェアレディZ	51
ブルーバード	51
ブルーバード シルフィ	52
プリメーラ	52
プレーリー リバティ	52
プレサージュ	52
プレジデント	52
マーチ	52~53
マイクラ	53
ムラーノ	53
モコ	53
ラティオ	53
ラフェスタ	53
ルークス	53
レパード	53
ローレル	53~54
ホンダ HONDA	ページ
CR-V	55
CR-X デルソル	55
CR-Z	55
HR-V	55

ホンダ HONDA	ページ
MDX	55
NSX	55
N-BOX	55~56
N-BOX カスタム	56
N-BOX カスタムSL	56
N-BOX スラッシュ	56
N-BOX スロープ	56
N-BOX+ (プラス)	56
N-ONE	56
N-VAN	57
N-WGN	57
N-WGN カスタム	57
S660	57
S2000	57
S-MX	57
Z	57
アヴァンシア	57
アクティ	57~58
アコード/アコードワゴン	58
アスコット	58
インサイト	58
インスパイア/インスパイアアルマス	59
インテグラ	59
ヴェゼル	59
エアウェイブ	59
エディックス	59
エリシオン/エリシオンプレステージ	59~60
エレメント	60
オデッセイ	60
オデッセイ F.D/T.H	60
オルティア	60
クイント	60
クロスロード	60
グレイス	60
ザッツ	61
シビック/シビック タイプR	61
シビックフェリオ	61~62
ジェイド	62
ステップワゴン	62
ステップワゴン スパーダ	62
ストリート	62~63
セイバー	63
ゼスト/ゼスト スパーク	63
トルネオ	63
ドマーニ	63
バモス	63
バモス ホビオ	64
パートナー	64
フィット	64
フィット アリア	64
フィット アルマス	65
フィット シャトル	65

車名索引

ホンダ HONDA	ページ
フリード	65
フリードスパイク	65
フリード+ (プラス)	65
プレリウド	65~66
モビリオ	66
モビリオ アルマス	66
モビリオ スパイク	66
ライフ	66
ラグレイト	66
レジェンド	66
マツダ MAZDA	ページ
AZ-オフロード	67
AZ-ワゴン/AZ-ワゴン カスタムスタイル	67
CX-7	67
MAZDA2	67
MPV	67
RX-8	67
アクセラ	67~68
アテンザ	68
イクシオン	68
エスケープ	68
カペラ	68
キャロル	68
スクラム	69
スピアーノ	69
デミオ	69
トリビュート	69
ビアンテ	69
ファミリア	70
フレア	70
フレアクロスオーバー	70
フレアワゴン	70
フリーダ	70
プレマシー	70
プロシード レバンテ	70~71
ベリーサ	71
ボンゴトラック	71
ボンゴバン	71
ボンゴフレンディ	71
ボンゴプロニートラック	71~72
ボンゴプロニーバン	72
ラピュータ	72
ロードスター	72
スバル SUBARU	ページ
BRZ	73
R1	73
R2	73
WRX	73
XV	73
YRV	73
インプレッサ	73~74
インプレッサ XV	74

スバル SUBARU	ページ
インプレッサ アネシス	74
エクシーガ	75
サンバー	75
サンバー ディアス	75
ステラ	75~76
ディアス	76
トレジア	76
フォレスター	76
プレオ	76
プレオ プラス	76
ルクラ	77
レヴォーグ	77
レオーネバン (ADバン)	77
レガシィ	77
レガシィ B4	77
レガシィ アウトバック	77
レガシィ ランカスター	78
三菱 MITSUBISHI	ページ
eK アクティブ	79
eK カスタム	79
eK クラッシィ	79
eK スペース	79
eK スポーツ	79
eK ワゴン	79
FTO	79
i(アイ)	79
RVR	79
アウトランダー/アウトランダー(PHEV)	79
アスパイア	79
エアトレック	80
カリスマ	80
キャンター	80
ギャラン	80
ギャランフォルティス	80
コルト	80
コルトプラス	80
シャリオ グランディス	80
タウンボックス	80
タウンボックス ワイド	81
タウンボックス ワゴン	81
チャレンジャー	81
ディアマンテ	81
ディオ	81
デリカ D:2	81
デリカ D:3	81
デリカ D:5	81
デリカトラック	81
トッポ	81
トッポ BJ	81~82
トッポ BJワイド	82
トライトン	82
パジェロ	82

車名索引

三菱 MITSUBISHI	ページ
パジェロ イオ	82
パジェロ ジュニア	82
パジェロ ミニ	82~83
ブラボー	83
ブラウディア	83
ミニカ/ミニカバン	83
ミニカ トップ/ミニカ トップ BJバン	83
ミニキャブ	83
ミラージュ	83
ミラージュ ディンゴ	83
ランサー/ランサーエボリューション	84
ランサーカーゴ	84
ランサーセディア	84
レグナム	84
スズキ SUZUKI	ページ
Kei	85
Keiワークス	85
MRワゴン	85
SX4	85
アルト	85
アルトラバン	86
アルトラバン ショコラ	86
アルトワークス	86
イグニス	86
エスクード	86
エブリィ/エブリィワゴン	86
エブリィ+(プラス)	87
エブリィランディ	87
エリオ	87
カルタス	87
カルタス クレセント	87
キザシ	87
キャリィ	87
クロスビー	87
シボレーMW	87
シボレークルーズ	87~88
グランドエスクード	88
ジムニー	88
ジムニー シエラ	88
ジムニー ワイド	88
スイフト	88
スペーシア	88
セルボ	88~89
ソリオ	89
ソリオ/ソリオバンディット	89
ツイン	89
ハスラー	89
パレット	89
ランディ	89
ワゴンR	89~90
ワゴンRソリオ	90
ワゴンRプラス	90

ダイハツ DAIHATSU	ページ
YRV	91
アトレーフ	91
アトレー/アトレーワゴン	91
アトレーデッキバン	91
アプローズ	91
アルティス	91~92
ウェイク	92
エッセ	92
オブティ	92
コペン	92
ストーリーア	92
ソニカ	92~93
タフト	93
タント	93
タント エグゼ	93
タント カスタム	93
テリオス	93
テリオスキッド	94
テリオスルキア	94
デルタ	94
デルタワイド	94
トール	94
ネイキッド	94
ハイゼット/ハイゼットカーゴ	94~96
ハイゼットデッキバン	96
ハイゼットトラック	96
ブーン	96
マックス	96
ミラ/ミラカスタム	97
ミラ アヴィ	98
ミラ イース	98
ミラ ココア	98
ミラ ジーノ	98
ミラ ジーノ1000	98
ムーヴ/ムーヴ カスタム	98~99
ムーヴ コンテ/ムーヴコンテ カスタム	99
ムーヴ ラテ	99
メビウス	99
ロッキー	99
いすゞ ISUZU	ページ
エルフ	100
コモ	100

トヨタ

TOYOTA

車両型式	エンジン 型式	排気量	年 式	Astemo品番	使用数	類 別 内 容	適応純正品番 (参考)
------	------------	-----	-----	----------	-----	---------	----------------

86

ZN6	FA20	2000	14.05~	U23T07-COIL	4		SU003-05259
-----	------	------	--------	-------------	---	--	-------------

bB

NCP30	2NZFE	1300	00.01~05.12	U13T01-COIL	4	EFI	90919-02240
NCP31	1NZFE	1500	00.01~05.12	U13T01-COIL	4	EFI	90919-02240
NCP34	1NZFE	1500	01.06~03.03	U13T01-COIL	4	EFI	90919-02240
NCP35	1NZFE	1500	00.01~05.12	U13T01-COIL	4	EFI	90919-02240
QNC20	K3VE	1300	06.01~10.07	U20T02-COIL	4	EFI	19070-B1011
QNC21	3SZVE	1500	06.01~10.07	U20T02-COIL	4	EFI	19070-B1011
QNC25	K3VE	1300	06.01~10.07	U20T02-COIL	4	EFI	19070-B1011

C-HR

NGX10	8NRFTS	1200	16.12~	U23T06-COIL	4		90919-02271
NGX50	8NRFTS	1200	16.12~	U23T06-COIL	4		90919-02271
ZYX10	2ZRFXE	1800	06.12~19.10	U21T01-COIL	4	EFI	90919-02272
ZYX11	2ZRFXE	1800	19.10~	U21T01-COIL	4	EFI	90919-02272

FJクルーザー

GSJ15W	1GRFE	4000	10.11~18.01	U13T06-COIL	6	EFI	90919-02256
--------	-------	------	-------------	-------------	---	-----	-------------

GRカローラ

GZEA14	G16EGTS	1600	22.12~24.09	U23T01-COIL	3		90919-02277
--------	---------	------	-------------	-------------	---	--	-------------

GRヤリス クロス

GXPA16	G16EGTS	1600	20.08~	U23T01-COIL	3		90919-02277
MXPA12	M15AFKS	1500	20.09~	U23T01-COIL	3		90919-02277

iQ

KGJ10	1KRFE	1000	08.11~11.02	U13T01-COIL	3	EFI	90919-02240
			11.02~16.03	U13T08-COIL	3	EFI	90919-02265
NGJ10	1NRFE	1300	09.08~16.03	U20T03-COIL	4	2WD	90919-02257

LEXUS CT

ZWA10	2ZRFXE	1800	10.12~	U19T14-COIL	4		90919-02258
-------	--------	------	--------	-------------	---	--	-------------

LEXUS ES300

AXZH10	A25AFXS	2500	18.10~21.08	U23T01-COIL	4		90919-02277
AXZH11	A25AFXS	2500	21.08~26.02	U23T01-COIL	4		90919-02277

LEXUS GS200t

ARL10	8ARFTS	2000	16.09~20.07	U23T03-COIL	4		90919-02269
GRL12	2GRFKS	3500	15.10~20.07	U23T05-COIL	6		90919-02273
GRL16	2GRFKS	3500	15.10~20.07	U23T05-COIL	6		90919-02273
GWL10	2GRFXE	3500	15.10~20.07	U23T05-COIL	6		90919-02273

トヨタ
TOYOTA日産
NISSANホンダ
HONDAマツダ
MAZDAスバル
SUBARU三菱
MITSUBISHIスズキ
SUZUKIダイハツ
DAIHATSUいすゞ
ISUZU対照表-1
純正品番順対照表-2
Astemo品番順

●印：生産終了品

車両型式	エンジン 型式	排気量	年 式	Astemo品番	使用数	類 別 内 容	適応純正品番 (参考)
------	------------	-----	-----	----------	-----	---------	----------------

LEXUS GS250

ARL10	8ARFTS	2000	16.09~20.07	U23T03-COIL	4		90919-02269
GRL11	4GRFSE	2500	11.12~16.08	U13T06-COIL	6		90919-02256
GRL12	2GRFKS	3500	15.10~20.07	U23T05-COIL	6		90919-02273
GRL16	2GRFKS	3500	15.10~20.07	U23T05-COIL	6		90919-02273
GWL10	2GRFXE	3500	15.10~20.07	U23T05-COIL	6		90919-02273

LEXUS GS300

ARL10	8ARFTS	2000	16.09~20.07	U23T03-COIL	4		90919-02269
AWL10	2ARFSE	2500	13.09~20.08	U13T06-COIL	4		90919-02256
GRL12	2GRFKS	3500	15.10~20.07	U23T05-COIL	6		90919-02273
GRL16	2GRFKS	3500	15.10~20.07	U23T05-COIL	6		90919-02273
GWL10	2GRFXE	3500	15.10~20.07	U23T05-COIL	6		90919-02273

LEXUS GS350

ARL10	8ARFTS	2000	16.09~20.07	U23T03-COIL	4		90919-02269
GRL10	2GRFSE	3500	11.12~15.10	U13T06-COIL	6		90919-02256
GRL12	2GRFKS	3500	15.10~20.07	U23T05-COIL	6		90919-02273
GRL15	2GRFSE	3500	11.12~15.10	U13T06-COIL	6		90919-02256
GRL16	2GRFKS	3500	15.10~20.07	U23T05-COIL	6		90919-02273
GRS191	2GRFSE	3500	05.08~12.01	U13T06-COIL	6		90919-02250
GRS196	2GRFSE	3500	05.08~12.01	U13T06-COIL	6		90919-02250
GWL10	2GRFXE	3500	15.10~20.07	U23T05-COIL	6		90919-02273

LEXUS GS450

ARL10	8ARFTS	2000	16.09~20.07	U23T03-COIL	4		90919-02269
GRL12	2GRFKS	3500	15.10~20.07	U23T05-COIL	6		90919-02273
GRL16	2GRFKS	3500	15.10~20.07	U23T05-COIL	6		90919-02273
GWL10	2GRFXE	3500	12.01~15.10	U13T06-COIL	6		90919-02256
			15.10~16.04	U13T06-COIL	6	識別マークなしのみ、除く(識別枠付)	90919-02256
			15.10~20.07	U23T05-COIL	6		90919-02273
GWS191	2GRFSE	3500	06.02~12.01	U13T06-COIL	6		90919-02250

LEXUS GS F

URL10	2URGSE	5000	15.10~20.07	U13T04-COIL	8		90919-02260
-------	--------	------	-------------	-------------	---	--	-------------

LEXUS GX550

VJA252	V35	3500	24.05~	U23T01-COIL	6		90919-02277
--------	-----	------	--------	-------------	---	--	-------------

LEXUS HS250

ANF10	2AZFXE	2400	09.07~18.02	U13T03-COIL	4	EFI	90919-02244
-------	--------	------	-------------	-------------	---	-----	-------------

LEXUS IS200t

ASE30	8ARFTS	2000	15.08~	U23T03-COIL	4		90919-02269
GSE31	2GRF	3500	15.10~20.09	U23T05-COIL	6		90919-02273
	2GRFKS	3500	20.09~	U23T05-COIL	6		90919-02273

LEXUS IS250

ASE30	8ARFTS	2000	15.08~	U23T03-COIL	4		90919-02269
GSE20	4GRFSE	2500	05.08~14.08	U13T06-COIL	6		90919-02250
GSE25	4GRFSE	2500	05.08~13.04	U13T06-COIL	6		90919-02250
GSE30	4GRFSE	2500	13.04~15.08	U13T06-COIL	6		90919-02256

西暦	1994	95	96	97	98	99	2000	01	02	03	04	05	06	07	08	09	10	11	12	13	14	15	16	17	18	19	20	21	22	23	24	25	26
和暦	平成6	7	8	9	10	11	12	13	14	15	16	17	18	19	20	21	22	23	24	25	26	27	28	29	30	令和元年	2	3	4	5	6	7	8

車両型式	エンジン 型式	排気量	年 式	Astemo品番	使用数	類 別 内 容	適応純正品番 (参考)
------	------------	-----	-----	----------	-----	---------	----------------

LEXUS IS250

GSE31	2GRF	3500	15.10~20.09	U23T05-COIL	6		90919-02273
	2GRFKS	3500	20.09~	U23T05-COIL	6		90919-02273
GSE35	4GRFSE	2500	13.04~16.10	U13T06-COIL	6		90919-02256

LEXUS IS300

ASE30	8ARFTS	2000	15.08~	U23T03-COIL	4		90919-02269
AVE30	2ARFSE	2500	13.04~	U13T06-COIL	4		90919-02256
AVE35	2ARFSE	2500	15.08~	U13T06-COIL	4		90919-02256
GSE31	2GRF	3500	15.10~20.09	U23T05-COIL	6		90919-02273
	2GRFKS	3500	20.09~	U23T05-COIL	6		90919-02273

LEXUS IS350

ASE30	8ARFTS	2000	15.08~	U23T03-COIL	4		90919-02269
GSE21	2GRFSE	3500	05.08~14.08	U13T06-COIL	6		90919-02250
GSE31	2GRFSE	3500	13.04~16.04	U13T06-COIL	6		90919-02256
	2GRF	3500	15.10~20.09	U23T05-COIL	6		90919-02273
	2GRFKS	3500	20.09~	U23T05-COIL	6		90919-02273

LEXUS IS500

ASE30	8ARFTS	2000	15.08~	U23T03-COIL	4		90919-02269
GSE31	2GRF	3500	15.10~20.09	U23T05-COIL	6		90919-02273
	2GRFKS	3500	20.09~	U23T05-COIL	6		90919-02273

LEXUS IS F

USE20	2URGSE	5000	07.12~14.08	U13T04-COIL	8		90919-02248
-------	--------	------	-------------	-------------	---	--	-------------

LEXUS LBX

MAYH10	M15AFXE	1500	23.12~	U23T01-COIL	3		90919-02277
MAYH15	M15AFXE	1500	23.12~	U23T01-COIL	3		90919-02277

LEXUS LC500/500h

GWZ100	8GRFXS	3500	23.05~	U23T05-COIL	6		90919-02273
--------	--------	------	--------	-------------	---	--	-------------

LEXUS LC500/500h(クーペ)

GWZ100	8GRFXS	3500	17.01~	U23T05-COIL	6		90919-02273
--------	--------	------	--------	-------------	---	--	-------------

LEXUS LM350h

AAWH10	A25	2500	23.11~26.03	U23T01-COIL	4		90919-02277
AAWH15	A25	2500	23.11~	U23T01-COIL	4		90919-02277
TAWH15	T24	2400	23.11~	U23T01-COIL	4		90919-02277

LEXUS LM500h

AAWH10	A25	2500	23.11~26.03	U23T01-COIL	4		90919-02277
AAWH15	A25	2500	23.11~	U23T01-COIL	4		90919-02277
TAWH15	T24	2400	23.11~	U23T01-COIL	4		90919-02277

車両型式	エンジン 型式	排気量	年 式	Astemo品番	使用数	類 別 内 容	適応純正品番 (参考)
------	------------	-----	-----	----------	-----	---------	----------------

LEXUS LS460

USF40	1URFSE	4600	06.08~17.08	U13T06-COIL	8		90919-02250
USF41	1URFSE	4600	08.09~17.08	U13T06-COIL	8		90919-02250
USF45	1URFSE	4600	08.09~17.08	U13T06-COIL	8		90919-02250
USF46	1URFSE	4600	08.09~17.08	U13T06-COIL	8		90919-02250

LEXUS LS500/500h

GVF50	8GRFXS	3500	17.10~	U23T05-COIL	6		90919-02273
GVF55	8GRFXS	3500	17.10~	U23T05-COIL	6		90919-02273
VXFA50	V35AFTS	3500	17.12~	U23T01-COIL	6		90919-02277
VXFA55	V35AFTS	3500	17.12~	U23T01-COIL	6		90919-02277

LEXUS LS600

UVF45	2URFSE	5000	07.04~17.08	U13T06-COIL	8		90919-02250
UVF46	2URFSE	5000	07.04~17.08	U13T06-COIL	8		90919-02250

LEXUS LX570

URJ201W	3URFE	5700	15.09~	U13T06-COIL	8		90919-02256
---------	-------	------	--------	-------------	---	--	-------------

LEXUS LX600

VJA310	V35AFTS	3500	21.12~	U23T01-COIL	6		90919-02277
--------	---------	------	--------	-------------	---	--	-------------

LEXUS NX200t

AGZ10	8ARFTS	2000	14.07~	U23T03-COIL	4		90919-02269
AGZ15	8ARFTS	2000	14.07~	U23T03-COIL	4		90919-02269

LEXUS NX250

AAZA20	A25AFKS	2500	21.11~25.06	U23T02-COIL	4		90919-02276
AAZA25	A25AFKS	2500	21.11~25.06	U23T02-COIL	4		90919-02276
AAZH20	A25AFXS	2500	21.11~	U23T01-COIL	4		90919-02277
AAZH25	A25AFXS	2500	21.11~	U23T01-COIL	4		90919-02277
AAZH26	A25AFXS	2500	21.11~	U23T01-COIL	4		90919-02277
TAZA25	T24AFTS	2400	21.11~	U23T01-COIL	4		90919-02277

LEXUS NX300

AGZ10	8ARFTS	2000	14.07~	U23T03-COIL	4		90919-02269
AGZ15	8ARFTS	2000	14.07~	U23T03-COIL	4		90919-02269
AYZ10	2ARFXE	2500	14.07~	U13T06-COIL	4	EFI	90919-02256
AYZ15	2ARFXE	2500	14.07~	U13T06-COIL	4	EFI	90919-02256

LEXUS NX300h

AGZ10	8ARFTS	2000	14.07~	U23T03-COIL	4		90919-02269
AGZ15	8ARFTS	2000	14.07~	U23T03-COIL	4		90919-02269

LEXUS NX350

AAZA20	A25AFKS	2500	21.11~25.06	U23T02-COIL	4		90919-02276
AAZA25	A25AFKS	2500	21.11~25.06	U23T02-COIL	4		90919-02276
AAZH20	A25AFXS	2500	21.11~	U23T01-COIL	4		90919-02277
AAZH25	A25AFXS	2500	21.11~	U23T01-COIL	4		90919-02277
AAZH26	A25AFXS	2500	21.11~	U23T01-COIL	4		90919-02277
TAZA25	T24AFTS	2400	21.11~	U23T01-COIL	4		90919-02277

西暦	1994	95	96	97	98	99	2000	01	02	03	04	05	06	07	08	09	10	11	12	13	14	15	16	17	18	19	20	21	22	23	24	25	26
和暦	平成6	7	8	9	10	11	12	13	14	15	16	17	18	19	20	21	22	23	24	25	26	27	28	29	30	令和元年	2	3	4	5	6	7	8

車両型式	エンジン 型式	排気量	年 式	Astemo品番	使用数	類 別 内 容	適応純正品番 (参考)
------	------------	-----	-----	----------	-----	---------	----------------

LEXUS NX350h

AAZA20	A25AFKS	2500	21.11~25.06	U23T02-COIL	4		90919-02276
AAZA25	A25AFKS	2500	21.11~25.06	U23T02-COIL	4		90919-02276
AAZH20	A25AFXS	2500	21.11~	U23T01-COIL	4		90919-02277
AAZH25	A25AFXS	2500	21.11~	U23T01-COIL	4		90919-02277
AAZH26	A25AFXS	2500	21.11~	U23T01-COIL	4		90919-02277
TAZA25	T24AFTS	2400	21.11~	U23T01-COIL	4		90919-02277

LEXUS NX450h+

AAZA20	A25AFKS	2500	21.11~25.06	U23T02-COIL	4		90919-02276
AAZA25	A25AFKS	2500	21.11~25.06	U23T02-COIL	4		90919-02276
AAZH20	A25AFXS	2500	21.11~	U23T01-COIL	4		90919-02277
AAZH25	A25AFXS	2500	21.11~	U23T01-COIL	4		90919-02277
AAZH26	A25AFXS	2500	21.11~	U23T01-COIL	4		90919-02277
TAZA25	T24AFTS	2400	21.11~	U23T01-COIL	4		90919-02277

LEXUS RC200t

ASC10	8ARFTS	2000	15.10~	U23T03-COIL	4		90919-02269
GSC10	2GRF	3500	15.10~	U23T05-COIL	6		90919-02273

LEXUS RC300

ASC10	8ARFTS	2000	15.10~	U23T03-COIL	4		90919-02269
AVC10	2ARFSE	2500	14.09~	U13T06-COIL	4		90919-02256
GSC10	2GRF	3500	15.10~	U23T05-COIL	6		90919-02273

LEXUS RC300h

ASC10	8ARFTS	2000	15.10~	U23T03-COIL	4		90919-02269
GSC10	2GRF	3500	15.10~	U23T05-COIL	6		90919-02273

LEXUS RC350

ASC10	8ARFTS	2000	15.10~	U23T03-COIL	4		90919-02269
GSC10	2GRFSE	3500	14.09~16.04	U13T06-COIL	6		90919-02256
	2GRF	3500	15.10~	U23T05-COIL	6		90919-02273

LEXUS RC F

USC10	2URGSE	5000	14.09~	U13T04-COIL	8		90919-02260
-------	--------	------	--------	-------------	---	--	-------------

LEXUS RX

AGL10W	1ARFE	2700	10.08~15.09	U13T06-COIL	4	EFI	90919-02256
GGL10W	2GRFE	3500	08.12~15.09	U19T15-COIL	6	2WD	90919-02255
GGL15W	2GRFE	3500	08.12~15.09	U19T15-COIL	6	4WD	90919-02255
GGL16W	2GRFE	3500	08.12~15.09	U19T15-COIL	6	4WD	90919-02255
GYL10W	2GRFXE	3500	08.12~15.09	U19T15-COIL	6	2WD	90919-02255
GYL15W	2GRFXE	3500	08.12~15.09	U19T15-COIL	6	4WD	90919-02255
GYL16W	2GRFXE	3500	08.12~15.09	U19T15-COIL	6	4WD	90919-02255

LEXUS RX200t

AGL20W	8ARFTS	2000	15.09~	U23T03-COIL	4		90919-02269
GYL20	2GRFXS	3500	15.10~17.03	U23T05-COIL	6		90919-02273
GYL25	2GRFXS	3500	15.10~17.03	U23T05-COIL	6		90919-02273

●印：生産終了品

車両型式	エンジン 型式	排気量	年 式	Astemo品番	使用数	類 別 内 容	適応純正品番 (参考)
------	------------	-----	-----	----------	-----	---------	----------------

LEXUS RX300

AGL20W	8ARFTS	2000	15.09~	U23T03-COIL	4		90919-02269
GYL20	2GRFXS	3500	15.10~17.03	U23T05-COIL	6		90919-02273
GYL25	2GRFXS	3500	15.10~17.03	U23T05-COIL	6		90919-02273

LEXUS RX350

AALH10	A25AFXS	2500	22.11~	U23T01-COIL	4		90919-02277
AALH15	A25AFXS	2500	22.11~	U23T01-COIL	4		90919-02277
AALH16	A25AFXS	2500	22.11~	U23T01-COIL	4		90919-02277
TALA10	T24AFTS	2400	22.11~	U23T01-COIL	4		90919-02277
TALA15	T24AFTS	2400	22.11~	U23T01-COIL	4		90919-02277
TALH17	T24AFTS	2400	22.11~	U23T01-COIL	4		90919-02277

LEXUS RX350h

AALH10	A25AFXS	2500	22.11~	U23T01-COIL	4		90919-02277
AALH15	A25AFXS	2500	22.11~	U23T01-COIL	4		90919-02277
AALH16	A25AFXS	2500	22.11~	U23T01-COIL	4		90919-02277
TALA10	T24AFTS	2400	22.11~	U23T01-COIL	4		90919-02277
TALA15	T24AFTS	2400	22.11~	U23T01-COIL	4		90919-02277
TALH17	T24AFTS	2400	22.11~	U23T01-COIL	4		90919-02277

LEXUS RX450h

AGL20W	8ARFTS	2000	15.09~	U23T03-COIL	4		90919-02269
GYL20	2GRFXS	3500	15.10~17.03	U23T05-COIL	6		90919-02273
GYL25	2GRFXS	3500	15.10~17.03	U23T05-COIL	6		90919-02273

LEXUS RX450h+

AALH10	A25AFXS	2500	22.11~	U23T01-COIL	4		90919-02277
AALH15	A25AFXS	2500	22.11~	U23T01-COIL	4		90919-02277
AALH16	A25AFXS	2500	22.11~	U23T01-COIL	4		90919-02277
TALA10	T24AFTS	2400	22.11~	U23T01-COIL	4		90919-02277
TALA15	T24AFTS	2400	22.11~	U23T01-COIL	4		90919-02277
TALH17	T24AFTS	2400	22.11~	U23T01-COIL	4		90919-02277

LEXUS RX500h

AALH10	A25AFXS	2500	22.11~	U23T01-COIL	4		90919-02277
AALH15	A25AFXS	2500	22.11~	U23T01-COIL	4		90919-02277
AALH16	A25AFXS	2500	22.11~	U23T01-COIL	4		90919-02277
TALA10	T24AFTS	2400	22.11~	U23T01-COIL	4		90919-02277
TALA15	T24AFTS	2400	22.11~	U23T01-COIL	4		90919-02277
TALH17	T24AFTS	2400	22.11~	U23T01-COIL	4		90919-02277

LEXUS UX200

MZAA10	M20AFKS	2000	18.10~22.07	U23T02-COIL	4		90919-02276
MZAH10	M20AFXS	2000	18.11~	U23T01-COIL	4		90919-02277
MZAH11	M20AFXS	2000	22.07~	U23T01-COIL	4		90919-02277
MZAH15	M20AFXS	2000	18.11~	U23T01-COIL	4		90919-02277
MZAH16	M20AFXS	2000	22.07~	U23T01-COIL	4		90919-02277

西暦	1994	95	96	97	98	99	2000	01	02	03	04	05	06	07	08	09	10	11	12	13	14	15	16	17	18	19	20	21	22	23	24	25	26
和暦	平成6	7	8	9	10	11	12	13	14	15	16	17	18	19	20	21	22	23	24	25	26	27	28	29	30	令和元年	2	3	4	5	6	7	8

車両型式	エンジン 型式	排気量	年 式	Astemo品番	使用数	類 別 内 容	適応純正品番 (参考)
------	------------	-----	-----	----------	-----	---------	----------------

LEXUS UX250h

MZAA10	M20AFKS	2000	18.10~22.07	U23T02-COIL	4		90919-02276
MZAH10	M20AFXS	2000	18.11~	U23T01-COIL	4		90919-02277
MZAH11	M20AFXS	2000	22.07~	U23T01-COIL	4		90919-02277
MZAH15	M20AFXS	2000	18.11~	U23T01-COIL	4		90919-02277
MZAH16	M20AFXS	2000	22.07~	U23T01-COIL	4		90919-02277

LEXUS UX300e

MZAA10	M20AFKS	2000	22.07~	U23T02-COIL	4		90919-02276
MZAH10	M20AFXS	2000	18.11~	U23T01-COIL	4		90919-02277
MZAH11	M20AFXS	2000	22.07~	U23T01-COIL	4		90919-02277
MZAH15	M20AFXS	2000	18.11~	U23T01-COIL	4		90919-02277
MZAH16	M20AFXS	2000	22.07~	U23T01-COIL	4		90919-02277

LEXUS UX300h

MZAA10	M20AFKS	2000	22.07~	U23T02-COIL	4		90919-02276
MZAH10	M20AFXS	2000	18.11~	U23T01-COIL	4		90919-02277
MZAH11	M20AFXS	2000	22.07~	U23T01-COIL	4		90919-02277
MZAH15	M20AFXS	2000	18.11~	U23T01-COIL	4		90919-02277
MZAH16	M20AFXS	2000	22.07~	U23T01-COIL	4		90919-02277

MR2

SW20	3SGE	2000	91.12~97.12	U12T02-COIL	1	EFI	90919-02197
	3SGTE	2000	91.12~99.08	U12T02-COIL	1	TURBO	90919-02197

MR-S

ZZW30	1ZZFE	1800	99.10~07.07	U13T05-COIL	4	EFI	90919-02239
-------	-------	------	-------------	-------------	---	-----	-------------

RAV4

ACA31W	2AZFE	2400	05.11~16.06	U13T03-COIL	4	EFI	90919-02244
			06.05~09.03	U13T04-COIL	4	EngineNo=CXXXXXX-GXXXXXX, MARK 02248,T2005,C2002,EFI	90919-02248
ACA36W	2AZFE	2400	05.11~16.06	U13T03-COIL	4	EFI	90919-02244
			06.05~09.03	U13T04-COIL	4	EngineNo=CXXXXXX-GXXXXXX, MARK 02248,T2005,C2002,EFI	90919-02248
AXAH52	A25AFXS	2500	19.04~24.09	U23T01-COIL	4		90919-02277
AXAH54	A25AFXS	2500	19.04~	U23T01-COIL	4		90919-02277
MXAA52	M20AFKS	2000	19.04~24.09	U23T02-COIL	4		90919-02276
MXAA54	M20AFKS	2000	19.04~	U23T02-COIL	4		90919-02276

RAV4 L/J

ACA20W	1AZFSE	2000	00.05~05.11	U13T04-COIL	4		90919-02247
ACA21W	1AZFSE	2000	00.05~05.11	U13T04-COIL	4		90919-02247
SXA10C	3SFE	2000	97.09~00.05	U12T18-COIL	1	NO.1,EFI	90919-02217
					1	NO.2,EFI	90919-02218
SXA10G	3SFE	2000	97.09~00.05	U12T18-COIL	1	NO.1,EFI	90919-02217
					1	NO.2,EFI	90919-02218
SXA10W	3SFE	2000	97.09~00.05	U12T18-COIL	1	NO.1,EFI	90919-02217
					1	NO.2,EFI	90919-02218
SXA11G	3SFE	2000	97.09~00.05	U12T18-COIL	1	NO.1,EFI	90919-02217
					1	NO.2,EFI	90919-02218

●印：生産終了品

車両型式	エンジン 型式	排気量	年 式	Astemo品番	使用数	類 別 内 容	適応純正品番 (参考)
------	------------	-----	-----	----------	-----	---------	----------------

RAV4 L/J

SXA11W	3SFE	2000	97.09~00.05	U12T18-COIL	1	NO.1,EFI	90919-02217
					1	NO.2,EFI	90919-02218
SXA15G	3SFE	2000	97.09~00.05	U12T18-COIL	1	NO.1,EFI	90919-02217
					1	NO.2,EFI	90919-02218
SXA16G	3SFE	2000	97.09~00.05	U12T18-COIL	1	NO.1,EFI	90919-02217
					1	NO.2,EFI	90919-02218
ZCA25W	1ZZFE	1800	00.05~05.11	U13T05-COIL	4	EFI	90919-02239
ZCA26W	1ZZFE	1800	00.05~05.11	U13T05-COIL	4	EFI	90919-02239

RAV4 PHV

AXAP54	A25AFXS	2500	20.06~	U23T01-COIL	4		90919-02277
--------	---------	------	--------	-------------	---	--	-------------

WILL Vi

NCP19	2NZFE	1300	00.01~01.12	U13T01-COIL	4	EFI	90919-02240
-------	-------	------	-------------	-------------	---	-----	-------------

WILL VS

NZE127	1NZFE	1500	02.01~04.04	U13T01-COIL	4	EFI	90919-02240
ZZE127	1ZZFE	1800	01.04~04.04	U13T05-COIL	4	EFI	90919-02239
ZZE129	1ZZFE	1800	01.04~04.04	U13T05-COIL	4	EFI	90919-02239

WILL サイファ

NCP70	2NZFE	1300	02.09~05.07	U13T01-COIL	4	EFI	90919-02240
NCP75	1NZFE	1500	02.09~05.07	U13T01-COIL	4	EFI	90919-02240

アイシス

ANM10G	1AZFSE	2000	04.09~09.09	U13T04-COIL	4		90919-02248
ANM10W	1AZFSE	2000	04.09~09.09	U13T04-COIL	4		90919-02248
ANM15G	1AZFSE	2000	04.09~09.09	U13T04-COIL	4		90919-02248
ANM15W	1AZFSE	2000	04.09~09.09	U13T04-COIL	4		90919-02248
ZGM10	2ZRFAE	1800	09.09~18.01	U19T14-COIL	4		90919-02258
ZGM11	3ZRFAE	2000	09.09~18.01	U19T14-COIL	4		90919-02258
ZGM15	2ZRFAE	1800	09.09~18.01	U19T14-COIL	4		90919-02258
ZNM10G	1ZZFE	1800	04.09~09.09	U13T05-COIL	4	MARK 90919-02239,EFI	90919-02239
ZNM10W	1ZZFE	1800	04.09~09.09	U13T05-COIL	4	MARK 90919-02239,EFI	90919-02239

アクア

NHP10	1NZFXE	1500	11.12~	U13T08-COIL	4	EFI	90919-02265
MXPK10	M15AFXE	1500	21.06~24.03	U23T01-COIL	3		90919-02277
MXPK11	M15AFXE	1500	21.06~	U23T01-COIL	3		90919-02277
MXPK15	M15AFXE	1500	21.06~24.03	U23T01-COIL	3		90919-02277
MXPK16	M15AFXE	1500	21.06~	U23T01-COIL	3		90919-02277

アベンシス

AZT250	1AZFSE	2000	03.07~08.11	U13T04-COIL	4		90919-02248
AZT250W	1AZFSE	2000	03.07~08.11	U13T04-COIL	4		90919-02248
AZT251	2AZFSE	2400	05.06~08.11	U13T04-COIL	4		90919-02248
AZT251W	2AZFSE	2400	05.06~08.11	U13T04-COIL	4		90919-02248
AZT255	1AZFSE	2000	03.09~08.11	U13T04-COIL	4		90919-02248
AZT255W	1AZFSE	2000	03.09~08.11	U13T04-COIL	4		90919-02248
ZRT272	3ZRFAE	2000	11.07~18.07	U19T14-COIL	4		90919-02258

西暦	1994	95	96	97	98	99	2000	01	02	03	04	05	06	07	08	09	10	11	12	13	14	15	16	17	18	19	20	21	22	23	24	25	26
和暦	平成6	7	8	9	10	11	12	13	14	15	16	17	18	19	20	21	22	23	24	25	26	27	28	29	30	令和元年	2	3	4	5	6	7	8

車両型式	エンジン 型式	排気量	年 式	Astemo品番	使用数	類 別 内 容	適応純正品番 (参考)
------	------------	-----	-----	----------	-----	---------	----------------

アリオン/プレミオ

AZT240	1AZFSE	2000	01.12~07.05	U13T04-COIL	4		90919-02247
NZT240	1NZFE	1500	01.12~07.05	U13T01-COIL	4	EFI	90919-02240
NZT260	1NZFE	1500	07.05~21.03	U13T04-COIL	4	EFI	90919-02248
ZRT260	2ZRFE	1800	07.05~10.04	U19T14-COIL	4		90919-02258
	2ZRFAE	1800	10.04~21.03	U19T14-COIL	4		90919-02258
ZRT261	3ZRFAE	2000	07.12~20.09	U19T14-COIL	4		90919-02258
ZRT265	2ZRFE	1800	07.05~10.04	U19T14-COIL	4		90919-02258
ZZT240	1ZZFE	1800	01.12~07.05	U13T05-COIL	4	EFI	90919-02239
ZZT245	1ZZFE	1800	01.12~07.05	U13T05-COIL	4	EFI	90919-02239

アリスト

JZS147	2JZGE	3000	91.10~97.08	U12T02-COIL	1	EFI	90919-02197
JZS160	2JZGE	3000	97.08~05.01	U22T01-COIL	3		90919-02216
JZS161	2JZGTE	3000	97.08~05.01	U22T01-COIL	3		90919-02216
UZS143	1UZFE	4000	92.10~97.08	U12T02-COIL	2	EFI	90919-02197

アルテツァ

GXE10	1GFE	2000	98.10~05.07	U13T02-COIL	6	EFI	90919-02230
SXE10	3SGE	2000	01.05~05.07	U13T05-COIL	4	EFI	90919-02239
JCE10	2JZGE	3000	01.06~05.07	U22T01-COIL	3		90919-02216
JCE15	2JZGE	3000	01.06~05.07	U22T01-COIL	3		90919-02216

アルテツァ ジータ

GXE10W	1GFE	2000	01.06~05.07	U13T02-COIL	6	EFI	90919-02230
GXE15W	1GFE	2000	02.01~05.07	U13T02-COIL	6	EFI	90919-02230
JCE10	2JZGE	3000	01.06~05.07	U22T01-COIL	3		90919-02216
JCE15	2JZGE	3000	01.06~05.07	U22T01-COIL	3		90919-02216

アルファード

AAHH40	A25	2500	23.06~	U23T01-COIL	4		90919-02277
AAHH45	A25	2500	23.06~	U23T01-COIL	4		90919-02277
AGH30W	2ARFE	2500	15.01~	U13T06-COIL	4	EFI	90919-02256
AGH35W	2ARFE	2500	15.01~	U13T06-COIL	4	EFI	90919-02256
ANH10W	2AZFE	2400	02.05~08.04	U13T03-COIL	4	MARK 90919-02243, 90919-02244,EFI	90919-02243
ANH15W	2AZFE	2400	02.05~08.04	U13T03-COIL	4	MARK 90919-02243, 90919-02244,EFI	90919-02243
ANH20W	2AZFE	2400	08.04~15.01	U13T03-COIL	4	EFI	90919-02244
				U13T04-COIL	4	EngineNo=CXXXXXX-GXXXXXX, MARK C2002,02260,C2###, T2###,EFI	90919-C2002
ANH25W	2AZFE	2400	08.04~15.01	U13T03-COIL	4	EFI	90919-02244
				U13T04-COIL	4	EngineNo=CXXXXXX-GXXXXXX, MARK C2002,02260,C2###, T2###,EFI	90919-C2002
ATH10W	2AZFXE	2400	03.07~08.03	U13T03-COIL	4	Hybrid,MARK 90919-02243, 90919-02244,EPI	90919-02243
			05.09~05.11	U13T04-COIL	4	Hybrid,MARK 90919-02248, EPI	90919-02248
ATH20W	2AZFXE	2400	11.10~15.01	U13T03-COIL	4	Hybrid,EFI	90919-02266
AYH30W	2ARFXE	2500	15.01~	U13T06-COIL	4	EFI	90919-02256
GGH20W	2GRFE	3500	08.04~15.01	U19T15-COIL	6	2WD	90919-02251

●印：生産終了品

車両型式	エンジン型式	排気量	年式	Astemo品番	使用数	類別内容	適応純正品番(参考)
------	--------	-----	----	----------	-----	------	------------

アルファード

GGH25W	2GRFE	3500	08.04~15.01	U19T15-COIL	6	4WD	90919-02251
GGH30W	2GRFE	3500	15.01~18.01	U19T15-COIL	6	2WD	90919-02255
GGH30	2GRFKS	3500	23.07~	U23T05-COIL	6		90919-02273
GGH35W	2GRFE	3500	15.01~18.01	U19T15-COIL	6	4WD	90919-02255
GGH35	2GRFKS	3500	23.07~	U23T05-COIL	6		90919-02273
MNH10	1MZFE	3000	02.05~08.04	U19T11-COIL	6		90919-02234
MNH15	1MZFE	3000	02.05~08.04	U19T11-COIL	6		90919-02234
TAHA40	T24AFTS	2400	23.06~	U23T01-COIL	4		90919-02277
TAHA45	T24AFTS	2400	23.06~	U23T01-COIL	4		90919-02277

アレックス

NZE121	1NZFE	1500	01.01~04.04	U13T01-COIL	4		90919-02240
			04.04~06.09	U13T04-COIL	4		90919-02260
NZE124	1NZFE	1500	01.01~06.09	U13T01-COIL	4		90919-02240
ZZE122	1ZZFE	1800	02.09~06.09	U13T05-COIL	4		90919-02262
ZZE124	1ZZFE	1800	02.09~06.09	U13T05-COIL	4		90919-02262

イスト

NCP110	1NZFE	1500	07.07~16.04	U13T04-COIL	4	EFI	90919-02248
NCP115	1NZFE	1500	07.07~16.04	U13T04-COIL	4	EFI	90919-02248
NCP60	2NZFE	1300	02.04~07.07	U13T01-COIL	4	EFI	90919-02240
NCP61	1NZFE	1500	02.04~07.07	U13T01-COIL	4	EFI	90919-02240
NCP65	1NZFE	1500	02.04~07.07	U13T01-COIL	4	EFI	90919-02240
ZSP110	2ZRFE	1800	07.07~10.08	U19T14-COIL	4		90919-02258

イプサム

ACM21W	2AZFE	2400	01.05~05.09	U13T03-COIL	4	EFI	90919-02243
			05.09~05.11	U13T04-COIL	4	MARK 90919-02248,EFI	90919-02248
			05.11~09.12	U13T03-COIL	4	EFI	90919-02244
ACM26W	2AZFE	2400	01.05~05.09	U13T03-COIL	4	EFI	90919-02243
			05.09~05.11	U13T04-COIL	4	MARK 90919-02248,EFI	90919-02248
			05.11~09.12	U13T03-COIL	4	EFI	90919-02244
SXM10G	3SFE	2000	96.05~01.05	U12T18-COIL	1	NO.1,EFI	90919-02217
					1	NO.2,EFI	90919-02218
SXM15G	3SFE	2000	96.05~01.05	U12T18-COIL	1	NO.1,EFI	90919-02217
					1	NO.2,EFI	90919-02218

ウィッシュ

ANE10G	1AZFSE	2000	03.04~09.03	U13T04-COIL	4		90919-02248
ANE11W	1AZFSE	2000	03.04~09.03	U13T04-COIL	4		90919-02248
ZGE20	2ZRFAE	1800	09.03~17.11	U19T14-COIL	4		90919-02258
ZGE21	3ZRFAE	2000	09.03~12.04	U19T14-COIL	4		90919-02258
ZGE22	3ZRFAE	2000	09.03~17.11	U19T14-COIL	4		90919-02258
ZGE25	2ZRFAE	1800	09.03~17.11	U19T14-COIL	4		90919-02258
ZNE10G	1ZZFE	1800	03.01~09.03	U13T05-COIL	4	EFI	90919-02239
ZNE14G	1ZZFE	1800	03.01~09.03	U13T05-COIL	4	EFI	90919-02239

ウインダム

MCV20	1MZFE	3000	96.08~01.07	U19T11-COIL	4		90919-02234
MCV30	1MZFE	3000	01.07~06.03	U19T11-COIL	4		90919-02234
VCV11	4VZFE	2500	93.08~96.08	U12T02-COIL	1	EFI	90919-02197

西暦	1994	95	96	97	98	99	2000	01	02	03	04	05	06	07	08	09	10	11	12	13	14	15	16	17	18	19	20	21	22	23	24	25	26
和暦	平成6	7	8	9	10	11	12	13	14	15	16	17	18	19	20	21	22	23	24	25	26	27	28	29	30	令和元年	2	3	4	5	6	7	8

トヨタ

TOYOTA

車両型式	エンジン型式	排気量	年式	Astemo品番	使用数	類別内容	適応純正品番 (参考)
------	--------	-----	----	----------	-----	------	----------------

ヴァンガード

ACA33W	2AZFE	2400	05.11~16.06	U13T03-COIL	4	EFI	90919-02244
			06.05~10.02	U13T04-COIL	4	EngineNo=CXXXXXX-GXXXXXX, MARK T2005,C2002,EFI	90919-T2005
ACA38W	2AZFE	2400	05.11~16.06	U13T03-COIL	4	EFI	90919-02244
			06.05~10.02	U13T04-COIL	4	EngineNo=CXXXXXX-GXXXXXX, MARK T2005,C2002,EFI	90919-T2005

ヴィッツ

KSP130	1KRFE	1000	10.12~14.04	U13T05-COIL	3	EFI	90919-02262
KSP130	1KRFE	1000	14.04~	U23T04-COIL	3		90919-02270
KSP90	1KRFE	1000	05.01~10.12	U13T05-COIL	3	EFI	90919-02239
NCP10	2NZFE	1300	99.09~05.01	U13T01-COIL	4	EFI	90919-02240
NCP13	1NZFE	1500	99.08~05.01	U13T01-COIL	4	EFI	90919-02240
NCP131	1NZFE	1500	10.12~20.01	U13T04-COIL	4	EFI	90919-02260
NCP15	2NZFE	1300	99.08~05.01	U13T01-COIL	4	EFI	90919-02240
NCP91	1NZFE	1500	05.01~10.12	U13T04-COIL	4	EFI	90919-02248
NCP95	2NZFE	1300	05.01~10.10	U13T01-COIL	4	EFI	90919-02240
			10.10~10.12	U13T08-COIL	4	EFI	90919-02265
NHP130	1NZFXE	1500	17.01~20.01	U13T08-COIL	4	EFI	90919-02265
NSP130	1NRFE	1300	10.12~14.04	U20T03-COIL	4	2WD	90919-02257
	1NRFKE	1300	14.04~20.01	U20T03-COIL	4	2WD	90919-02257
NSP135	1NRFE	1300	10.12~20.01	U20T03-COIL	4	4WD	90919-02257
SCP10	1SZFE	1000	99.01~05.01	U13T01-COIL	4	EFI	90919-02229
SCP13	2SZFE	1300	02.12~05.01	U13T01-COIL	4	EFI	90919-02240
SCP90	2SZFE	1300	05.01~10.05	U13T01-COIL	4	EFI	90919-02240
			10.05~10.12	U13T08-COIL	4	EFI	90919-02265

ヴィッツ GRMN

NSP131	2ZRFE	1800	17.11~18.04	U19T14-COIL	4		90919-02258
--------	-------	------	-------------	-------------	---	--	-------------

ヴィッツ ハイブリッド

KSP130	1KRFE	1000	14.04~	U23T04-COIL	3		90919-02270
--------	-------	------	--------	-------------	---	--	-------------

ヴェルファイア

AAHH40	A25	2500	23.06~	U23T01-COIL	4		90919-02277
AAHH45	A25	2500	23.06~	U23T01-COIL	4		90919-02277
AGH30W	2ARFE	2500	15.01~	U13T06-COIL	4	EFI	90919-02256
AGH35W	2ARFE	2500	15.01~	U13T06-COIL	4	EFI	90919-02256
ANH20W	2AZFE	2400	08.04~15.01	U13T03-COIL	4	EFI	90919-02244
				U13T04-COIL	4	EngineNo=CXXXXXX-GXXXXXX, MARK C2002,02260,C2###, T2###,EFI	90919-C2002
ANH25W	2AZFE	2400	08.04~15.01	U13T03-COIL	4	EFI	90919-02244
				U13T04-COIL	4	EngineNo=CXXXXXX-GXXXXXX, MARK C2002,02260,C2###, T2###,EFI	90919-C2002
ATH20W	2AZFXE	2400	11.10~15.01	U13T03-COIL	4	Hybrid,EFI	90919-02266
AYH30W	2ARFXE	2500	15.01~	U13T06-COIL	4	EFI	90919-02256
GGH20W	2GRFE	3500	08.04~15.01	U19T15-COIL	6	2WD	90919-02251
GGH25W	2GRFE	3500	08.04~15.01	U19T15-COIL	6	4WD	90919-02251
GGH30W	2GRFE	3500	15.01~18.01	U19T15-COIL	6	2WD	90919-02255
GGH30	2GRFKS	3500	23.07~	U23T05-COIL	6		90919-02273

●印：生産終了品

トヨタ
TOYOTA日産
NISSANホンダ
HONDAマツダ
MAZDAスバル
SUBARU三菱
MITSUBISHIスズキ
SUZUKIダイハツ
DAIHATSUいすゞ
ISUZU対照表-1
純正品番順対照表-2
Astemo品番順

車両型式	エンジン 型式	排気量	年 式	Astemo品番	使用数	類 別 内 容	適応純正品番 (参考)
------	------------	-----	-----	----------	-----	---------	----------------

ヴェルファイア

GGH35W	2GRFE	3500	15.01~18.01	U19T15-COIL	6	4WD	90919-02255
GGH35	2GRFKS	3500	23.07~	U23T05-COIL	6		90919-02273
TAHA40	T24AFTS	2400	23.06~	U23T01-COIL	4		90919-02277
TAHA45	T24AFTS	2400	23.06~	U23T01-COIL	4		90919-02277

ヴェロツサ

GX110	1GFE	2000	01.06~04.04	U13T02-COIL	6	EFI	90919-02230
GX115	1GFE	2000	01.06~04.04	U13T02-COIL	6	EFI	90919-02230
JZX110	1JZGTE	2500	01.06~04.04	U22T01-COIL	3		90919-02216

ヴォクシー

AZR60G	1AZFSE	2000	01.11~07.06	U13T04-COIL	4		90919-02247
AZR65G	1AZFSE	2000	01.11~07.06	U13T04-COIL	4		90919-02247
MZRA90	M20AFKS	2000	22.01~	U23T02-COIL	4		90919-02276
MZRA92	M20AFKS	2000	22.01~	U23T02-COIL	4		90919-02276
MZRA95	M20AFKS	2000	22.01~	U23T02-COIL	4		90919-02276
MZRA97	M20AFKS	2000	22.01~	U23T02-COIL	4		90919-02276
ZRR70	3ZRFE	2000	07.06~10.04	U19T14-COIL	4		90919-02258
	3ZRFAE	2000	10.04~14.01	U19T14-COIL	4		90919-02258
ZRR75	3ZRFE	2000	07.06~10.04	U19T14-COIL	4		90919-02258
	3ZRFAE	2000	10.04~14.01	U19T14-COIL	4		90919-02258
ZRR80	3ZRFAE	2000	14.01~21.12	U19T14-COIL	4		90919-02258
ZRR85	3ZRFAE	2000	14.01~21.12	U19T14-COIL	4		90919-02258
ZWR80	2ZRFXE	1800	14.01~21.12	U19T14-COIL	4		90919-02258
ZWR90	2ZRFXE	1800	22.01~	U23T01-COIL	4		90919-02277
ZWR92	2ZRFXE	1800	22.01~	U23T01-COIL	4		90919-02277
ZWR95	2ZRFXE	1800	22.01~	U23T01-COIL	4		90919-02277

ヴォルツ

ZZE136	1ZZFE	1800	02.05~04.02	U13T05-COIL	4	EFI	90919-02239
ZZE138	1ZZFE	1800	02.05~04.02	U13T05-COIL	4	EFI	90919-02239

エスクァイア

ZRR80	3ZRFAE	2000	14.01~21.12	U19T14-COIL	4		90919-02258
ZRR85	3ZRFAE	2000	14.01~21.12	U19T14-COIL	4		90919-02258
ZWR80	2ZRFXE	1800	14.01~21.12	U19T14-COIL	4		90919-02258

エステイマ

ACR50W	2AZFE	2400	06.01~19.10	U13T03-COIL	4	EFI	90919-02244
			06.06~19.10	U13T04-COIL	4	EngineNo=CXXXXXX-GXXXXXX, MARK 02248,T2005,C2002, 02260,C2###,T2###,EFI	90919-02248
ACR55W	2AZFE	2400	06.06~19.10	U13T03-COIL	4	EFI	90919-02244
			06.06~19.10	U13T04-COIL	4	EngineNo=CXXXXXX-GXXXXXX, MARK 02248,T2005,C2002, 02260,C2###,T2###,EFI	90919-02248
AHR10W	2AZFXE	2400	01.05~06.01	U13T03-COIL	4	MARK 90919-02243,EFI	90919-02243
AHR20W	2AZFXE	2400	06.06~12.04	U13T03-COIL	4	MARK 90919-02244,EFI	90919-02244
			10.09~19.10	U13T03-COIL	4	MARK 90919-02266,EFI	90919-02266
GSR50W	2GRFE	3500	06.01~16.05	U19T15-COIL	6	2WD	90919-02251
GSR55W	2GRFE	3500	06.01~16.05	U19T15-COIL	6	4WD	90919-02251

西暦	1994	95	96	97	98	99	2000	01	02	03	04	05	06	07	08	09	10	11	12	13	14	15	16	17	18	19	20	21	22	23	24	25	26
和暦	平成6	7	8	9	10	11	12	13	14	15	16	17	18	19	20	21	22	23	24	25	26	27	28	29	30	令和元年	2	3	4	5	6	7	8

トヨタ

TOYOTA

車両型式	エンジン 型式	排気量	年 式	Astemo品番	使用数	類 別 内 容	適応純正品番 (参考)
------	------------	-----	-----	----------	-----	---------	----------------

エスティマ

MCR30	1MZFE	3000	99.12~06.01	U19T11-COIL	6		90919-02234
MCR40	1MZFE	3000	99.12~06.01	U19T11-COIL	6		90919-02234

エスティマ T/L

ACR30W	2AZFE	2400	00.02~06.01	U13T03-COIL	4	EFI	90919-02243
ACR40W	2AZFE	2400	00.02~06.01	U13T03-COIL	4	EFI	90919-02243

オリジン

JCG17	2JZGE	3000	00.08~01.04	U22T01-COIL	3		90919-02216
-------	-------	------	-------------	-------------	---	--	-------------

オーパ

ACT10	1AZFSE	2000	00.08~05.04	U13T04-COIL	4		90919-02247
ZCT10	1ZZFE	1800	00.04~05.04	U13T05-COIL	4	EFI	90919-02239
ZCT15	1ZZFE	1800	00.04~05.04	U13T05-COIL	4	EFI	90919-02239

オーリス

NZE151H	1NZFE	1500	06.10~12.08	U13T04-COIL	4	EFI	90919-02248
NZE154H	1NZFE	1500	06.10~12.08	U13T04-COIL	4	EFI	90919-02248
NZE181H	1NZFE	1500	12.08~18.05	U13T04-COIL	4	EFI	90919-02260
NZE184H	1NZFE	1500	12.08~18.05	U13T04-COIL	4	EFI	90919-02260
NRE185	8NRFTS	1200	15.03~	U23T06-COIL	4		90919-02271
ZRE152	2ZRFE	1800	06.10~09.10	U19T14-COIL	4		90919-02258
	2ZRFAE	1800	09.10~12.08	U19T14-COIL	4		90919-02258
ZRE154	2ZRFE	1800	06.10~09.10	U19T14-COIL	4		90919-02258
	2ZRFAE	1800	09.10~12.08	U19T14-COIL	4		90919-02258
ZRE186	2ZRFAE	1800	12.08~18.05	U19T14-COIL	4		90919-02258
ZWE186	2ZRFXE	1800	16.04~18.05	U19T14-COIL	4		90919-02258

カムリ

ACV30	2AZFE	2400	01.09~06.01	U13T03-COIL	4	EFI	90919-02243
ACV35	2AZFE	2400	01.09~06.01	U13T03-COIL	4	EFI	90919-02243
ACV40	2AZFE	2400	06.01~06.05	U13T03-COIL	4	EFI	90919-02244
			06.05~11.01	U13T04-COIL	4	EFI	90919-T2005
			11.01~11.08	U13T03-COIL	4	MARK 90919-02244,EFI	90919-02244
ACV45	2AZFE	2400	06.01~06.05	U13T03-COIL	4	EFI	90919-02244
			06.05~11.01	U13T04-COIL	4	EFI	90919-T2005
			11.01~11.08	U13T03-COIL	4	MARK 90919-02244,EFI	90919-02244
AVV50	2ARFXE	2500	11.08~17.04	U13T06-COIL	4	EFI	90919-02256
SV40	4SFE	1800	94.06~96.05	U12T02-COIL	1	EFI	90919-02197
			96.05~98.06	U12T18-COIL	1	NO.1,EFI	90919-02217
					1	NO.2,EFI	90919-02218
SV41	3SFE	2000	94.06~96.05	U12T02-COIL	1	Lumi yell,EFI	90919-02197
				U12T14-COIL	1	ZX,EFI	90919-02163
			96.05~98.06	U12T18-COIL	1	NO.1,EFI	90919-02217
					1	NO.2,EFI	90919-02218
					1	NO.2,EFI	90919-02218
SV42	3SFE	2000	94.06~96.05	U12T02-COIL	1	EFI	90919-02197
				U12T14-COIL	1	EFI	90919-02163
			96.05~98.06	U12T18-COIL	1	NO.1,EFI	90919-02217
1	NO.2,EFI	90919-02218					
SV43	3SFE	2000	94.06~96.05	U12T02-COIL	1	EFI	90919-02197
			96.05~98.06	U12T18-COIL	1	NO.1,EFI	90919-02217
					1	NO.2,EFI	90919-02218

●印：生産終了品

トヨタ
TOYOTA日産
NISSANホンダ
HONDAマツダ
MAZDAスバル
SUBARU三菱
MITSUBISHIスズキ
SUZUKIダイハツ
DAIHATSUいすゞ
ISUZU対照表-1
純正品番順対照表-2
Astemo品番順

トヨタ

TOYOTA

車両型式	エンジン型式	排気量	年式	Astemo品番	使用数	類別内容	適応純正品番(参考)
------	--------	-----	----	----------	-----	------	------------

カムリ

SXV20	5SFE	2200	96.12~01.09	U12T18-COIL	1	NO.1,EFI	90919-02217
					1	NO.2,EFI	90919-02218
SXV25	5SFE	2200	96.12~01.09	U12T18-COIL	1	NO.1,EFI	90919-02217
					1	NO.2,EFI	90919-02218

カムリ グラシア

SXV20	5SFE	2200	96.12~01.09	U12T18-COIL	1	NO.1,EFI	90919-02217
					1	NO.2,EFI	90919-02218
SXV20W	5SFE	2200	96.12~01.09	U12T18-COIL	1	NO.1,EFI	90919-02217
					1	NO.2,EFI	90919-02218
SXV25W	5SFE	2200	96.12~01.09	U12T18-COIL	1	NO.1,EFI	90919-02217
					1	NO.2,EFI	90919-02218

カムリ ハイブリッド

AXVH70	A25AFXS	2500	17.06~	U23T01-COIL	4		90919-02277
AXVH75	A25AFXS	2500	17.06~	U23T01-COIL	4		90919-02277

カーリーナ

AT190	4AFE	1600	94.08~96.08	U12T14-COIL	1	EFI	90919-02163
AT191	7AFE	1800	94.08~96.08	U12T14-COIL	1	EFI	90919-02163
AT192	5AFE	1500	92.08~96.08	U12T01-COIL	1	EFI	90919-02164
AT212	5AFE	1500	96.08~01.12	U12T01-COIL	1	EFI	90919-02164
ST195	3SFE	2000	94.08~96.08	U12T14-COIL	1	EFI	90919-02163
ST215	3SFE	2000	96.08~01.12	U12T18-COIL	1	NO.1,EFI	90919-02217
					1	NO.2,EFI	90919-02218

カーリーナ ED

ST200	4SFE	1800	96.06~98.04	U12T18-COIL	1	NO.1,EFI	90919-02217
					1	NO.2,EFI	90919-02218
ST202	3SFE	2000	93.09~96.06 96.06~98.04	U12T14-COIL U12T18-COIL	1	EFI	90919-02163
					1	NO.1,EFI	90919-02217
					1	NO.2,EFI	90919-02218
ST203	3SFE	2000	93.09~96.06 96.06~98.04	U12T14-COIL U12T18-COIL	1	EFI	90919-02163
					1	NO.1,EFI	90919-02217
					1	NO.2,EFI	90919-02218

カルディナ

AZT241W	1AZFSE	2000	02.09~07.06	U13T04-COIL	4		90919-02248
AZT246W	1AZFSE	2000	02.09~07.06	U13T04-COIL	4		90919-02248
ET196V	5EFE	1500	92.11~97.08	U12T01-COIL	1	EFI	90919-02164
			97.08~02.06	U12T18-COIL	1	NO.2,3,EFI	90919-02220
ST191G	3SFE	2000	92.11~96.01 96.01~02.06	U12T14-COIL U12T18-COIL	1	EFI	90919-02163
					1	NO.1,EFI	90919-02217
					1	NO.2,EFI	90919-02218
ST195G	3SFE	2000	92.11~96.01 96.01~02.06	U12T14-COIL U12T18-COIL	1	EFI	90919-02163
					1	NO.1,EFI	90919-02217
					1	NO.2,EFI	90919-02218
ST198V	3SFE	2000	96.01~02.06	U12T18-COIL	1	NO.1,EFI	90919-02217
					1	NO.2,EFI	90919-02218
ST210G	3SFE	2000	97.08~02.09	U12T18-COIL	1	NO.1,EFI	90919-02217
					1	NO.2,EFI	90919-02218

西暦	1994	95	96	97	98	99	2000	01	02	03	04	05	06	07	08	09	10	11	12	13	14	15	16	17	18	19	20	21	22	23	24	25	26
和暦	平成6	7	8	9	10	11	12	13	14	15	16	17	18	19	20	21	22	23	24	25	26	27	28	29	30	令和元年	2	3	4	5	6	7	8

TOYOTA
トヨタ

NISSAN
日産

HONDA
ホンダ

MAZDA
マツダ

SUBARU
スバル

MITSUBISHI
三菱

SUZUKI
スズキ

DAIHATSU
ダイハツ

ISUZU
いすゞ

純正品番順
対照表-1

Astemo品番順
対照表-2

車両型式	エンジン 型式	排気量	年 式	Astemo品番	使用数	類 別 内 容	適応純正品番 (参考)
------	------------	-----	-----	----------	-----	---------	----------------

カルディナ

ST215G	3SFE	2000	97.08~02.09	U12T18-COIL	1	NO.1,EFI	90919-02217
					1	NO.2,EFI	90919-02218
ST246W	3SGTE	2000	02.09~05.01	U13T05-COIL	4	TURBO	90919-02239
			05.01~07.06	U13T05-COIL	4	TURBO	90919-02239
ZZT241W	1ZZFE	1800	02.09~07.06	U13T05-COIL	4	EFI	90919-02239

カレン

ST206	3SFE	2000	96.06~98.07	U12T18-COIL	1	NO.1,EFI	90919-02217
					1	NO.2,EFI	90919-02218
ST207	3SFE	2000	96.06~98.07	U12T18-COIL	1	NO.1,EFI	90919-02217
					1	NO.2,EFI	90919-02218
ST208	4SFE	1800	96.06~98.07	U12T18-COIL	1	NO.1,EFI	90919-02217
					1	NO.2,EFI	90919-02218

カローラ

AE100	5AFE	1500	91.06~00.08	U12T01-COIL	1	EFI	90919-02164
AE100G	5AFE	1500	91.09~00.08	U12T01-COIL	1	EFI	90919-02164
AE101	4AFE	1600	91.06~00.08	U12T01-COIL	1	EFI	90919-02164
	4AGE	1600	91.06~00.08	U12T02-COIL	1	EFI	90919-02197
AE101G	4AGE	1600	96.05~00.08	U12T02-COIL	1	EFI	90919-02197
AE104	4AFE	1600	91.09~00.08	U12T01-COIL	1	EFI	90919-02164
AE104G	4AFE	1600	95.05~00.08	U12T01-COIL	1	EFI	90919-02164
AE109V	4AFE	1600	96.05~02.06	U12T01-COIL	1	EFI	90919-02164
AE110	5AFE	1500	95.05~00.08	U12T01-COIL	1	EFI	90919-02164
AE111	4AFE	1600	95.05~00.08	U12T01-COIL	1	EFI	90919-02164
	4AGE	1600	97.04~00.08	U12T02-COIL	1	EFI	90919-02197
AE114	4AFE	1600	95.05~00.08	U12T01-COIL	1	EFI	90919-02164
EE101	4EFE	1300	91.06~95.05	U12T01-COIL	1	EFI	90919-02164
EE102V	4EFE	1300	91.06~97.05	U12T01-COIL	1	EFI	90919-02164
			97.04~02.06	U12T18-COIL	1	NO.2,3,EFI	90919-02220
EE103V	5EFE	1500	91.06~97.05	U12T01-COIL	1	EFI	90919-02164
			97.04~02.06	U12T18-COIL	1	NO.2,3,EFI	90919-02220
EE104G	5EFE	1500	91.06~97.05	U12T01-COIL	1	EFI	90919-02164
			97.04~02.06	U12T18-COIL	1	NO.2,3,EFI	90919-02220
EE106V	2E	1300	91.09~94.01	U12T01-COIL	1		90919-02164
EE107V	3E	1500	91.09~94.01	U12T01-COIL	1		90919-02164
EE108G	3E	1500	91.09~94.01	U12T01-COIL	1		90919-02164
EE111	4EFE	1300	95.05~97.04	U12T01-COIL	1	EFI	90919-02164
			97.04~00.08	U12T18-COIL	1	NO.2,3,EFI	90919-02220
MZEA12	M20AFKS	2000	20.06~	U23T02-COIL	4		90919-02276
MZEA17	M15AFKS	1500	22.10~	U23T01-COIL	3		90919-02277
NRE210	8NRFTS	1200	19.08~	U23T06-COIL	4		90919-02271
NZE120	2NZFE	1300	00.08~02.09	U13T01-COIL	4	EFI	90919-02240
			02.09~06.10	U13T01-COIL	4	EFI	90919-02240
NZE121	1NZFE	1500	00.08~06.09	U13T01-COIL	4	5MT,EFI	90919-02240
			04.04~06.09	U13T04-COIL	4	4AT,EFI	90919-02248
NZE124	1NZFE	1500	00.08~06.10	U13T01-COIL	4	EFI	90919-02240
ZRE212	2ZRFAE	1800	19.08~	U23T02-COIL	4		90919-02276
ZWE211W	2ZRFXE	1800	19.08~	U21T01-COIL	4	EFI	90919-02272
ZWE211	2ZRFXE	1800	19.08~	U21T01-COIL	4	EFI	90919-02272
ZWE214W	2ZRFXE	1800	19.09~	U21T01-COIL	4	EFI	90919-02272
ZWE214	2ZRFXE	1800	19.08~	U21T01-COIL	4	EFI	90919-02272
ZWE215	2ZRFXE	1800	22.10~	U23T01-COIL	4		90919-02277

●印：生産終了品

車両型式	エンジン 型式	排気量	年 式	Astemo品番	使用数	類 別 内 容	適応純正品番 (参考)
------	------------	-----	-----	----------	-----	---------	----------------

カローラ

ZWE219	2ZRFXE	1800	22.10~	U23T01-COIL	4		90919-02277
ZZE122	1ZZFE	1800	00.08~06.10	U13T05-COIL	4	EFI	90919-02239
ZZE124	1ZZFE	1800	00.08~06.10	U13T05-COIL	4	EFI	90919-02239

カローラ FX

AE101	4AFE	1600	92.05~95.05	U12T01-COIL	1	EFI	90919-02164
	4AGE	1600	92.05~95.05	U12T02-COIL	1	EFI	90919-02197

カローラ アクシオ

NKE165	1NZFXE	1500	13.08~	U13T08-COIL	4	EFI	90919-02265
NRE160	1NRFE	1300	12.04~19.08	U20T03-COIL	4	2WD	90919-02257
NRE161	2NRFKE	1500	15.03~	U20T03-COIL	4	2WD	90919-02257
NZE141	1NZFE	1500	06.09~12.05	U13T04-COIL	4	EFI	90919-02248
NZE144	1NZFE	1500	06.09~12.05	U13T04-COIL	4	EFI	90919-02248
NZE161	1NZFE	1500	12.04~	U13T04-COIL	4	EFI	90919-02260
NZE164	1NZFE	1500	12.04~	U13T04-COIL	4	EFI	90919-02260
ZRE142	2ZRFE	1800	06.09~10.05	U19T14-COIL	4		90919-02258
	2ZRFAE	1800	10.05~12.04	U19T14-COIL	4		90919-02258
ZRE144	2ZRFE	1800	06.09~10.05	U19T14-COIL	4		90919-02258
	2ZRFAE	1800	10.05~12.04	U19T14-COIL	4		90919-02258

カローラ クロス

MXGA10	M20AFKS	2000	23.10~	U23T02-COIL	4		90919-02276
ZSG10	2ZRFAE	1800	21.08~23.10	U23T02-COIL	4		90919-02276
ZVG11	2ZRFXE	1800	21.08~	U21T01-COIL	4	EFI	90919-02272
			23.10~	U23T01-COIL	4		90919-02277
ZVG15	2ZRFXE	1800	21.08~	U21T01-COIL	4	EFI	90919-02272
			23.10~	U23T01-COIL	4		90919-02277
ZVG13	2ZRFXE	1800	23.10~	U23T01-COIL	4		90919-02277
ZVG16	2ZRFXE	1800	23.10~	U23T01-COIL	4		90919-02277

カローラ スパシオ

AE111N	4AFE	1600	97.01~01.05	U12T01-COIL	1	EFI	90919-02164
AE115N	7AFE	1800	97.01~01.05	U12T01-COIL	1	EFI	90919-02164
NZE121N	1NZFE	1500	01.05~07.06	U13T01-COIL	4	EFI	90919-02240
ZZE122N	1ZZFE	1800	01.05~07.06	U13T05-COIL	4	EFI	90919-02239
ZZE124N	1ZZFE	1800	01.05~07.06	U13T05-COIL	4	EFI	90919-02239

カローラ スポーツ

ZWE211	2ZRFXE	1800	18.06~20.05	U21T01-COIL	4	EFI	90919-02272
ZWE213	2ZRFXE	1800	20.06~22.08	U21T01-COIL	4	EFI	90919-02272
ZWE219	2ZRFXE	1800	22.10~	U23T01-COIL	4		90919-02277
NRE210H	8NRFTS	1200	18.06~	U23T06-COIL	4		90919-02271
NRE214H	8NRFTS	1200	18.06~	U23T06-COIL	4		90919-02271
MZEA12	M20AFKS	2000	22.10~	U23T02-COIL	4		90919-02276

カローラ セレス

AE100	5AFE	1500	92.05~98.08	U12T01-COIL	1	EFI	90919-02164
AE101	4AGE	1600	92.05~98.08	U12T02-COIL	1	EFI	90919-02197
	4AFE	1600	92.05~98.08	U12T01-COIL	1	EFI	90919-02164

西暦	1994	95	96	97	98	99	2000	01	02	03	04	05	06	07	08	09	10	11	12	13	14	15	16	17	18	19	20	21	22	23	24	25	26
和暦	平成6	7	8	9	10	11	12	13	14	15	16	17	18	19	20	21	22	23	24	25	26	27	28	29	30	令和元年	2	3	4	5	6	7	8

トヨタ

TOYOTA

車両型式	エンジン 型式	排気量	年 式	Astemo品番	使用数	類 別 内 容	適応純正品番 (参考)
------	------------	-----	-----	----------	-----	---------	----------------

カローラ ツーリング

MZEA12	M20AFKS	2000	20.06~	U23T02-COIL	4		90919-02276
MZEA17	M15AFKS	1500	22.10~	U23T01-COIL	3		90919-02277
ZRE212	2ZRFAE	1800	19.08~	U23T02-COIL	4		90919-02276
ZWE215	2ZRFXE	1800	22.10~	U23T01-COIL	4		90919-02277
ZWE219	2ZRFXE	1800	22.10~	U23T01-COIL	4		90919-02277

カローラ フィールダー

NKE165G	1NZFXE	1500	13.08~	U13T08-COIL	4	EFI	90919-02265
NRE161G	2NRFKE	1500	15.03~	U20T03-COIL	4	2WD	90919-02257
NZE121G	1NZFE	1500	00.08~06.09	U13T01-COIL	4	MT,EFI	90919-02240
			04.04~06.09	U13T04-COIL	4	AT,EFI	90919-02248
NZE124G	1NZFE	1500	00.08~06.10	U13T01-COIL	4	EFI	90919-02240
NZE141G	1NZFE	1500	06.09~12.05	U13T04-COIL	4	EFI	90919-02248
NZE144G	1NZFE	1500	06.09~12.05	U13T04-COIL	4	EFI	90919-02248
NZE161G	1NZFE	1500	12.04~	U13T04-COIL	4	EFI	90919-02260
NZE164G	1NZFE	1500	12.04~	U13T04-COIL	4	EFI	90919-02260
ZRE142	2ZRFE	1800	06.09~10.05	U19T14-COIL	4		90919-02258
	2ZRFAE	1800	10.05~12.04	U19T14-COIL	4		90919-02258
ZRE144	2ZRFE	1800	06.09~10.05	U19T14-COIL	4		90919-02258
	2ZRFAE	1800	10.05~12.04	U19T14-COIL	4		90919-02258
ZRE162	2ZRFAE	1800	12.04~19.08	U19T14-COIL	4		90919-02258
ZZE122G	1ZZFE	1800	00.08~06.10	U13T05-COIL	4	EFI	90919-02239
ZZE124G	1ZZFE	1800	00.08~06.10	U13T05-COIL	4	EFI	90919-02239

カローラ ランクス

NZE121	1NZFE	1500	01.01~04.04	U13T01-COIL	4	EFI	90919-02240
			04.04~06.09	U13T04-COIL	4	EFI	90919-02248
NZE124	1NZFE	1500	01.01~06.09	U13T01-COIL	4	EFI	90919-02240
ZZE122	1ZZFE	1800	02.09~06.09	U13T05-COIL	4	EFI	90919-02239
ZZE124	1ZZFE	1800	02.09~06.09	U13T05-COIL	4	EFI	90919-02239

カローラ ルミオン

NZE151N	1NZFE	1500	07.10~15.12	U13T04-COIL	4	EFI	90919-02248
ZRE152	2ZRFE	1800	07.10~09.12	U19T14-COIL	4		90919-02258
	2ZRFAE	1800	09.12~15.12	U19T14-COIL	4		90919-02258
ZRE154	2ZRFE	1800	07.10~09.12	U19T14-COIL	4		90919-02258
	2ZRFAE	1800	09.12~15.12	U19T14-COIL	4		90919-02258

カローラ レビン

AE100	5AFE	1500	91.06~95.05	U12T01-COIL	1	S,EFI	90919-02164
AE101	4AFE	1600	91.06~95.05	U12T01-COIL	1	SJ,EFI	90919-02164
	4AGE	1600	91.06~95.05	U12T02-COIL	1	GT,EFI	90919-02197
AE110	5AFE	1500	95.05~00.08	U12T01-COIL	1	FZ,EFI	90919-02164
AE111	4AFE	1600	95.05~00.08	U12T01-COIL	1	5MT,EFI	90919-02164
	4AGE	1600	95.05~00.08	U12T02-COIL	1	6MT,EFI	90919-02197

ガイア

ACM10G	1AZFSE	2000	01.04~04.09	U13T04-COIL	4		90919-02247
ACM15G	1AZFSE	2000	02.09~04.09	U13T04-COIL	4		90919-02248
SXM10G	3SFE	2000	98.05~01.04	U12T18-COIL	1	NO.1,EFI	90919-02217
					1	NO.2,EFI	90919-02218

●印：生産終了品

車両型式	エンジン型式	排気量	年式	Astemo品番	使用数	類別内容	適応純正品番(参考)
------	--------	-----	----	----------	-----	------	------------

ガイア

SXM15G	3SFE	2000	98.05~01.04	U12T18-COIL	1	NO.1,EFI	90919-02217
					1	NO.2,EFI	90919-02218

キャミ

J100E	HCEJ	1300	99.05~00.05	U18D02-COIL	2	EFI	19500-87101
J102E	K3VE	1300	00.05~05.12	U15D03-COIL	4	EFI	90048-52130
	K3VT	1300	00.05~05.12	U15D03-COIL	4	TURBO	90048-52130
J122E	K3VE	1300	00.05~05.12	U15D03-COIL	4	EFI	90048-52130

クイックデリバリー

BU280K	3RZFPE	2700	00.01~03.06	U13T07-COIL	4	LPG	90919-02237
RZU280K	3RZFPE	2700	03.06~04.06	U13T07-COIL	4	LPG	90919-02237
			03.06~06.10	U13T07-COIL	4	LPG,宅配仕様	90919-02237
RZU68VH	3RZFP	2700	96.10~99.08	U12T12-COIL	1	LPG,宅配仕様	90919-02135
XZU281K	3RZFPE	2700	04.06~06.10	U13T07-COIL	4	LPG,宅配仕様	90919-02237

クラウン エステート

GS171W	1GFE	2000	01.08~03.12	U13T02-COIL	6	EFI	90919-02230
--------	------	------	-------------	-------------	---	-----	-------------

クラウン コンフォート

YXS10	3YPE	2000	95.12~08.08	U12T12-COIL	1	スタガード [®] ,LPG	90919-02135
-------	------	------	-------------	-------------	---	-------------------------	-------------

クラウン マジェスタ

AWS215	2ARFSE	2500	14.07~18.04	U13T06-COIL	4		90919-02256
GWS214	2GRFXE	3500	13.09~18.04	U13T06-COIL	6		90919-02256
JZS149	2JZGE	3000	91.10~95.08	U12T02-COIL	1		90919-02197
JZS155	2JZGE	3000	95.08~96.09	U22T01-COIL	3		90919-02216
UZS141	1UZFE	4000	91.10~95.08	U12T02-COIL	2		90919-02197
UZS145	1UZFE	4000	92.10~95.08	U12T02-COIL	2		90919-02197
UZS147	1UZFE	4000	93.08~95.08	U12T02-COIL	2		90919-02197
UZS151	1UZFE	4000	95.08~97.07	U12T02-COIL	2		90919-02197
UZS155	1UZFE	4000	95.08~97.07	U12T02-COIL	2		90919-02197
UZS157	1UZFE	4000	95.08~97.07	U12T02-COIL	2		90919-02197
UZS171	1UZFE	4000	99.09~03.08	U13T02-COIL	8	EFI	90919-02230
UZS173	1UZFE	4000	99.09~03.08	U13T02-COIL	8	EFI	90919-02230
UZS175	1UZFE	4000	99.09~03.08	U13T02-COIL	8	EFI	90919-02230

クラウン パトロールカー

ARS220	8ARFTS	2000	21.06~	U23T03-COIL	4		90919-02269
AZSH21	A25AFXS	2500	21.06~	U23T01-COIL	4		90919-02277
AZSH20	A25AFXS	2500	18.06~22.04	U23T01-COIL	4		90919-02277
AZSH21	A25AFXS	2500	18.06~	U23T01-COIL	4		90919-02277
GRS202	3GRFSE	3000	15.10~	U23T05-COIL	6		90919-02273
GRS214	2GRFSE	3500	16.04~	U23T05-COIL	6		90919-02273

クラウン/クラウン アスリート

AWS210	2ARFSE	2500	13.01~18.04	U13T06-COIL	4		90919-02256
AWS211	2ARFSE	2500	14.07~18.04	U13T06-COIL	4		90919-02256
AZSH32	A25	2500	23.11~	U23T01-COIL	4		90919-02277
AZSH35	A25AFXS	2500	22.09~	U23T01-COIL	4		90919-02277
AZSH36	A25	2500	23.08~	U23T01-COIL	4		90919-02277

西暦	1994	95	96	97	98	99	2000	01	02	03	04	05	06	07	08	09	10	11	12	13	14	15	16	17	18	19	20	21	22	23	24	25	26
和暦	平成6	7	8	9	10	11	12	13	14	15	16	17	18	19	20	21	22	23	24	25	26	27	28	29	30	令和元年	2	3	4	5	6	7	8

車両型式	エンジン 型式	排気量	年式	Astemo品番	使用数	類別内容	適応純正品番 (参考)
------	------------	-----	----	----------	-----	------	----------------

クラウン/クラウン アスリート

AZSH37	A25	2500	23.08~	U23T01-COIL	4		90919-02277
GBS12	1GFE	2000	02.10~08.08	U13T02-COIL	6	EFI,Hybrid	90919-02230
GRS180	4GRFSE	2500	03.12~08.02	U13T06-COIL	6		90919-02250
GRS181	4GRFSE	2500	04.08~08.02	U13T06-COIL	6		90919-02250
GRS182	3GRFSE	3000	03.12~08.02	U13T06-COIL	6		90919-02250
GRS183	3GRFSE	3000	03.12~08.02	U13T06-COIL	6		90919-02250
GRS184	2GRFSE	3500	05.09~08.02	U13T06-COIL	6		90919-02250
GRS200	4GRFSE	2500	08.02~12.12	U13T06-COIL	6		90919-02250
GRS201	4GRFSE	2500	08.02~12.12	U13T06-COIL	6		90919-02250
GRS202	3GRFSE	3000	08.02~12.12	U13T06-COIL	6		90919-02250
GRS203	3GRFSE	3000	08.02~12.12	U13T06-COIL	6		90919-02250
GRS204	2GRFSE	3500	08.02~12.12	U13T06-COIL	6		90919-02250
GRS210	4GRFSE	2500	12.12~18.04	U13T06-COIL	6		90919-02256
GRS211	4GRFSE	2500	12.12~18.04	U13T06-COIL	6		90919-02256
GRS214	2GRFSE	3500	12.12~18.04	U13T06-COIL	6		90919-02256
GS151	1GFE	2000	98.08~01.08	U13T02-COIL	6		90919-02230
GS151H	1GFE	2000	98.08~01.08	U13T02-COIL	6		90919-02230
GS171	1GFE	2000	99.09~03.12	U13T02-COIL	6	EFI	90919-02230
GWS204	2GRFSE	3500	08.05~12.12	U13T06-COIL	6		90919-02250
GXS12	1GFE	2000	01.08~07.08	U13T02-COIL	6	EFI	90919-02230
JZS130	1JZGE	2500	96.09~99.04	U22T01-COIL	3		90919-02216
JZS130G	1JZGE	2500	90.08~96.09	U12T02-COIL	1		90919-02197
JZS131	1JZGE	2500	90.08~95.12	U12T02-COIL	1		90919-02197
JZS133	2JZGE	3000	91.10~95.12	U12T02-COIL	1		90919-02197
JZS135	2JZGE	3000	91.10~95.12	U12T02-COIL	1		90919-02197
JZS141	1JZGE	2500	91.10~95.08	U12T02-COIL	1		90919-02197
JZS143	2JZGE	3000	91.10~95.08	U12T02-COIL	1		90919-02197
JZS145	2JZGE	3000	91.10~95.08	U12T02-COIL	1		90919-02197
JZS151	1JZGE	2500	95.08~96.09	U12T02-COIL	1		90919-02197
			96.09~01.08	U22T01-COIL	3		90919-02216
JZS153	1JZGE	2500	95.08~96.09	U12T02-COIL	1		90919-02197
			96.09~01.08	U22T01-COIL	3		90919-02216
JZS155	2JZGE	3000	96.09~01.08	U22T01-COIL	3		90919-02216
JZS157	2JZGE	3000	96.09~99.09	U22T01-COIL	3		90919-02216
JZS171	1JZGE	2500	99.09~01.08	U22T01-COIL	3		90919-02216
	1JZGTE	2500	99.09~03.12	U22T01-COIL	3		90919-02216
JZS173	1JZGE	2500	99.09~07.06	U22T01-COIL	3		90919-02216
JZS175	2JZGE	3000	01.08~03.12	U22T01-COIL	3		90919-02216
JZS179	2JZGE	3000	99.09~03.12	U22T01-COIL	3		90919-02216
TZSH35	T24AFTS	2400	22.09~	U23T01-COIL	4		90919-02277
YXS10H	3YPE	2000	01.08~08.08	U12T12-COIL	1	LPG	90919-02135

クラウン/クラウン ハイブリッド

ARS210	8ARFTS	2000	15.09~18.04	U23T03-COIL	4		90919-02269
ARS220	8ARFTS	2000	18.06~	U23T03-COIL	4		90919-02269
GRS214	2GRFSE	3500	15.09~18.04	U23T05-COIL	6		90919-02273
GWS214	2GRFXE	3500	15.09~18.04	U23T05-COIL	6		90919-02273
GWS224	8GRFXS	3500	18.06~22.04	U23T05-COIL	6		90919-02273

クルーガー L/V

ACU20W	2AZFE	2400	00.11~07.05	U13T03-COIL	4	EFI	90919-02243
ACU25W	2AZFE	2400	00.11~05.09	U13T03-COIL	4	EFI	90919-02243

●印：生産終了品

トヨタ

TOYOTA

車両型式	エンジン 型式	排気量	年 式	Astemo品番	使用数	類 別 内 容	適応純正品番 (参考)
------	------------	-----	-----	----------	-----	---------	----------------

クルーガー L/V

MCU20	1MZFE	3000	00.11~07.05	U19T11-COIL	6		90919-02234
MCU25	1MZFE	3000	00.11~07.05	U19T11-COIL	6		90919-02234

クレスト

GX100	1GFE	2000	98.08~01.06	U13T02-COIL	6		90919-02230
GX105	1GFE	2000	98.08~01.06	U13T02-COIL	6		90919-02230
JZX100	1JZGE	2500	96.09~01.06	U22T01-COIL	3		90919-02216
JZX101	2JZGE	3000	96.09~01.06	U22T01-COIL	3		90919-02216
JZX105	1JZGE	2500	96.09~01.06	U22T01-COIL	3		90919-02216

グランビア

RCH11W	3RZFE	2700	95.08~98.04	U12T14-COIL	1	EFI	90919-02163
--------	-------	------	-------------	-------------	---	-----	-------------

コロナ

AT190	4AFE	1600	92.02~96.01	U12T01-COIL	1		90919-02164
ST140	1SU	1800	82.01~82.12	U12T12-COIL	1		90919-02135
			82.12~98.04	U12T13-COIL	1		90919-02139
ST191	3SFE	2000	92.02~96.01	U12T14-COIL	1		90919-02163
ST195	3SFE	2000	92.02~96.01	U12T14-COIL	1		90919-02163
YT140	2YPU	1800	82.12~98.04	U12T13-COIL	1	LPG	90919-02139

コロナ プレミオ

ST210	3SFE	2000	96.01~01.12	U12T18-COIL	1	NO.1,EFI	90919-02217
					1	NO.2,EFI	90919-02218
ST215	3SFE	2000	96.01~01.12	U12T18-COIL	1	NO.1,EFI	90919-02217
					1	NO.2,EFI	90919-02218
ZRT260	2ZRFE	1800	07.05~10.04	U19T14-COIL	4		90919-02258
	2ZRFAE	1800	10.04~21.03	U19T14-COIL	4		90919-02258
ZRT261	2ZRFAE	1800	07.12~20.09	U19T14-COIL	4		90919-02258
ZRT265	2ZRFE	1800	07.05~10.04	U19T14-COIL	4		90919-02258
	2ZRFAE	1800	10.04~21.03	U19T14-COIL	4		90919-02258

コペン

LA400A	KFVET	660	19.10~	U18D04-COIL	3		19500-B2050
--------	-------	-----	--------	-------------	---	--	-------------

コンフォート

SXS11Y	4SFE	1800	96.04~01.08	U12T02-COIL	1	EFI,教習車	90919-02197
TSS13Y	1TRFE	2000	07.09~18.01	U13T04-COIL	4	EFI,教習車	90919-02248
YXS11	3YPE	2000	95.12~08.08	U12T12-COIL	1	LPG,含む(教習車)	90919-02135
YXS11Y	3YPE	2000	95.12~08.08	U12T12-COIL	1	LPG,教習車	90919-02135

サイ

AZK10	2AZFXE	2400	09.11~12.04	U13T03-COIL	4	MARK 90919-02244,EFI	90919-02244
			10.09~13.08	U13T03-COIL	4	MARK 90919-02266,EFI	90919-02266
			13.08~18.02	U13T03-COIL	4	EFI	90919-02266

サクシード

NCP160V	1NZFE	1500	14.09~20.07	U13T04-COIL	4	EFI	90919-02260
NCP165V	1NZFE	1500	14.09~20.07	U13T04-COIL	4	EFI	90919-02260
NCP51V	1NZFE	1500	02.06~10.10	U13T01-COIL	4	EFI	90919-02240
			10.10~14.09	U13T08-COIL	4	EFI	90919-02265

西暦	1994	95	96	97	98	99	2000	01	02	03	04	05	06	07	08	09	10	11	12	13	14	15	16	17	18	19	20	21	22	23	24	25	26
和暦	平成6	7	8	9	10	11	12	13	14	15	16	17	18	19	20	21	22	23	24	25	26	27	28	29	30	令和元年	2	3	4	5	6	7	8

TOYOTA
トヨタNISSAN
日産HONDA
ホンダMAZDA
マツダSUBARU
スバルMITSUBISHI
三菱SUZUKI
スズキDAIHATSU
ダイハツISUZU
いすゞ純正品番順
対照表-1Astemo品番順
対照表-2

トヨタ

TOYOTA

車両型式	エンジン型式	排気量	年式	Astemo品番	使用数	類別内容	適応純正品番 (参考)
------	--------	-----	----	----------	-----	------	----------------

サクシード

NCP55V	1NZFE	1500	02.06~10.10	U13T01-COIL	4	EFI	90919-02240
			10.10~14.09	U13T08-COIL	4	EFI	90919-02265
NCP58G	1NZFE	1500	02.06~10.10	U13T01-COIL	4	EFI	90919-02240
			10.10~13.10	U13T08-COIL	4	EFI	90919-02265
NCP59G	1NZFE	1500	02.06~10.10	U13T01-COIL	4	EFI	90919-02240
			10.10~13.10	U13T08-COIL	4	EFI	90919-02265

サイノス

EL52	4EFE	1300	95.08~97.12	U12T01-COIL	1	MT,EFI	90919-02164
			97.12~99.07	U12T18-COIL	1	NO.2,3,AT,EFI	90919-02220
EL52C	4EFE	1300	95.08~98.02	U12T01-COIL	1	MT,EFI	90919-02164
			98.02~99.07	U12T18-COIL	1	NO.2,3,AT,EFI	90919-02220
EL54	5EFHE	1500	95.08~99.07	U12T14-COIL	1	MT,EFI	90919-02163
EL54C	5EFHE	1500	96.10~99.07	U12T14-COIL	1	AT,EFI	90919-02163

シエンタ

NCP175G	1NZFE	1500	15.06~22.07	U13T04-COIL	4	EFI	90919-02260
NCP81G	1NZFE	1500	03.09~15.06	U13T04-COIL	4	EFI	90919-02248
NCP85G	1NZFE	1500	03.09~10.08	U13T01-COIL	4	EFI	90919-02240
			11.06~14.09	U13T08-COIL	4	EFI	90919-02265
NSP170G	2NRFKE	1500	15.06~22.07	U20T03-COIL	4	2WD	90919-02257
NSP172G	2NRFKE	1500	15.06~22.07	U20T03-COIL	4	2WD	90919-02257
	1NZFXE	1500	15.06~22.07	U13T08-COIL	4	EFI	90919-02265
MXPC10	M15AFKS	1500	22.07~	U23T01-COIL	3		90919-02277
MXPC12	M15AFKS	1500	22.07~	U23T01-COIL	3		90919-02277
MXPL10	M15AFXE	1500	22.07~	U23T01-COIL	3		90919-02277
MXPL12	M15AFXE	1500	22.07~	U23T01-COIL	3		90919-02277

スープラ

JZA80	2JZGE	3000	93.05~02.08	U12T02-COIL	1	リフトバック,SZ,SZ-R,AT,MT,DOHC	90919-02197
	2JZGTE	3000	97.09~02.08	U22T01-COIL	3		90919-02216

スターレット

EP82	4EF	1300	89.12~96.01	U12T01-COIL	1		90919-02164
	4EFE	1300	89.12~96.01	U12T01-COIL	1	EFI	90919-02164
	4EFTE	1300	92.01~96.01	U12T02-COIL	1	TURBO	90919-02197
EP85	4EF	1300	89.12~96.01	U12T01-COIL	1		90919-02164
	4EFE	1300	89.12~96.01	U12T01-COIL	1	EFI	90919-02164
EP91	4EFE	1300	96.01~97.12	U12T01-COIL	1	EFI	90919-02164
			97.12~99.07	U12T18-COIL	1	NO.2,3,EFI	90919-02220
	4EFTE	1300	96.01~99.07	U12T02-COIL	1	TURBO	90919-02197
EP95	4EFE	1300	96.01~97.12	U12T01-COIL	1	EFI	90919-02164
			97.12~99.07	U12T18-COIL	1	NO.2,3,EFI	90919-02220

スパークー

S221E	K3VE	1300	00.09~03.03	U15D03-COIL	4	EFI	90048-52130
S231E	K3VE	1300	00.09~03.03	U15D03-COIL	4	EFI	90048-52130

●印：生産終了品

車両型式	エンジン型式	排気量	年式	Astemo品番	使用数	類別内容	適応純正品番(参考)
------	--------	-----	----	----------	-----	------	------------

スプリンター

AE100	5AFE	1500	91.06~95.05	U12T01-COIL	1	EFI	90919-02164
AE101	4AGE	1600	91.06~95.05	U12T02-COIL	1	DOHC	90919-02197
	4AFE	1600	91.06~95.05	U12T01-COIL	1	EFI	90919-02164
AE104	4AFE	1600	91.06~95.05	U12T01-COIL	1	EFI	90919-02164
AE109V	4AFE	1600	91.06~02.06	U12T01-COIL	1	EFI	90919-02164
AE114	4AFE	1600	95.05~00.08	U12T01-COIL	1	EFI	90919-02164
EE102V	4EFE	1300	91.06~97.05	U12T01-COIL	1	EFI	90919-02164
			97.04~02.06	U12T18-COIL	1	NO.2,3,EFI	90919-02220
EE103V	5EFE	1500	91.06~97.05	U12T01-COIL	1	EFI	90919-02164
			97.04~02.06	U12T18-COIL	1	NO.2,3,EFI	90919-02220
EE104G	5EFE	1500	91.06~97.05	U12T01-COIL	1	EFI	90919-02164
			97.04~02.06	U12T18-COIL	1	NO.2,3,EFI	90919-02220

スプリンター カリブ

AE111G	4AFE	1600	95.08~02.07	U12T01-COIL	1	Sツ-リッパ,EFI	90919-02164
	4AGE	1600	96.05~02.07	U12T02-COIL	1	BZツ-リッパ,EFI	90919-02197
AE114G	4AFE	1600	95.08~02.07	U12T01-COIL	1	EFI	90919-02164
AE115G	7AFE	1800	95.08~02.07	U12T01-COIL	1	EFI	90919-02164

スプリンター トレノ

AE101	4AFE	1600	91.06~98.08	U12T01-COIL	1	EFI	90919-02164
	4AGE	1600	91.06~98.08	U12T02-COIL	1	EFI,GT	90919-02197

スプリンター マリノ

AE101	4AFE	1600	92.05~98.08	U12T01-COIL	1	EFI	90919-02164
	4AGE	1600	92.05~98.08	U12T02-COIL	1	EFI	90919-02197

スペイド

NCP141	1NZFE	1500	12.07~15.07	U13T04-COIL	4	EFI	90919-02260
NCP145	1NZFE	1500	12.07~20.12	U13T04-COIL	4	EFI	90919-02260
NSP140	1NRFKE	1300	12.07~15.07	U20T03-COIL	4	2WD	90919-02257
NSP141	2NRFKE	1500	15.07~	U20T03-COIL	4	2WD	90919-02257

セプター

SXV10	5SFE	2200	92.11~96.08	U12T14-COIL	1	EFI	90919-02163
SXV15	5SFE	2200	92.12~96.07	U12T14-COIL	1	EFI	90919-02163
SXV15W	5SFE	2200	92.12~96.07	U12T14-COIL	1	EFI	90919-02163

セラ

EXY10	5EFHE	1500	92.06~95.12	U12T02-COIL	1	EFI	90919-02197
-------	-------	------	-------------	-------------	---	-----	-------------

セリカ

ST202	3SFE	2000	96.06~99.08	U12T18-COIL	1	NO.1,EFI	90919-02217
					1	NO.2,EFI	90919-02218
ST203	3SFE	2000	96.06~99.08	U12T18-COIL	1	NO.1,EFI	90919-02217
					1	NO.2,EFI	90919-02218
ZZT230	1ZZFE	1800	99.08~06.04	U13T05-COIL	4	EFI	90919-02239

西暦	1994	95	96	97	98	99	2000	01	02	03	04	05	06	07	08	09	10	11	12	13	14	15	16	17	18	19	20	21	22	23	24	25	26
和暦	平成6	7	8	9	10	11	12	13	14	15	16	17	18	19	20	21	22	23	24	25	26	27	28	29	30	令和元年	2	3	4	5	6	7	8

トヨタ

TOYOTA

車両型式	エンジン型式	排気量	年式	Astemo品番	使用数	類別内容	適応純正品番(参考)
------	--------	-----	----	----------	-----	------	------------

セルシオ

UCF20	1UZFE	4000	94.10~97.07	U12T02-COIL	2		90919-02197
UCF21	1UZFE	4000	94.10~97.07	U12T02-COIL	2		90919-02197
UCF30	3UZFE	4300	00.08~03.08	U13T02-COIL	8	EFI	90919-02230
UCF31	3UZFE	4300	00.08~03.08	U13T02-COIL	8	EFI	90919-02230

センチュリー

GRG75	2GRFXS	3500	23.10~	U23T05-COIL	6		90919-02273
-------	--------	------	--------	-------------	---	--	-------------

ソアラ

JZZ30	1JZGTE	2500	96.08~00.12	U22T01-COIL	3		90919-02216
JZZ31	2JZGE	3000	94.01~97.09	U12T02-COIL	1	EFI	90919-02197
			97.09~00.12	U22T01-COIL	3		90919-02216
UZZ30	1UZFE	4000	91.05~94.01	U12T02-COIL	2	EFI	90919-02197
UZZ31	1UZFE	4000	91.05~97.09	U12T02-COIL	2	EFI	90919-02197
UZZ32	1UZFE	4000	91.05~97.09	U12T02-COIL	2	EFI	90919-02197
UZZ40	3UZFE	4300	01.04~03.08	U13T02-COIL	8	EFI	90919-02230

ターセル

EL51	4EFE	1300	94.09~97.12	U12T01-COIL	1	EFI	90919-02164
			97.12~99.07	U12T18-COIL	1	NO.2,3,EFI	90919-02220
EL53	5EFE	1500	94.09~97.12	U12T01-COIL	1	EFI	90919-02164
			97.12~99.07	U12T18-COIL	1	NO.2,3,EFI	90919-02220
EL55	5EFE	1500	94.09~97.12	U12T01-COIL	1	EFI	90919-02164
			97.12~99.07	U12T18-COIL	1	NO.2,3,EFI	90919-02220

タンク/ルーミー

M900A	1KR-FE	1000	16.11~	U22T02-COIL	3		90919-02281
M910A	1KR-FE	1000	16.11~	U22T02-COIL	3		90919-02281

ダイナ/トヨエース

BU68DH	3B	3400	89.10~95.05	U12T12-COIL	1		90919-02135
			27LPG	2700	93.11~95.05	U12T12-COIL	1
LY161	3YP	2000	96.10~99.05	U12T13-COIL	1	LPG	90919-02139
LY162	3YP	2000	98.05~01.07	U12T13-COIL	1	LPG	90919-02139
LY230	3RZFPE	2700	01.07~04.08	U13T07-COIL	4	LPG	90919-02237
LY280	3RZFPE	2700	01.07~04.08	U13T07-COIL	4	LPG	90919-02237
RZU100	3RZFE	2700	95.05~00.05	U12T14-COIL	1	EFI	90919-02163
				U12T12-COIL	1	LPG	90919-02135
RZU100A	3RZFE	2700	95.05~00.05	U12T14-COIL	1	EFI	90919-02163
				U12T12-COIL	1	LPG	90919-02135
RZU100H	3RZFP	2700	95.05~00.05	U12T12-COIL	1	LPG	90919-02135
RZU140	3RZFE	2700	97.08~00.07	U12T14-COIL	1	EFI	90919-02163
RZU300	3RZFE	2700	00.05~03.06	U12T18-COIL	1	NO.1,EFI	90919-02217
					1	NO.2,EFI	90919-02220
			03.06~07.05	U13T07-COIL	4	EFI	90919-02237
			3RZFPE	2700	00.05~07.05	U13T07-COIL	4
RZU300A	3RZFE	2700	05.05~07.05	U13T07-COIL	4	EFI	90919-02237
RZU301	3RZFPE	2700	03.06~07.05	U13T07-COIL	4	LPG	90919-02237
RZU340	3RZFE	2700	00.05~03.06	U12T18-COIL	1	NO.1,EFI	90919-02217
					1	NO.2,EFI	90919-02220
			03.06~07.05	U13T07-COIL	4	EFI	90919-02237
RZY220	1RZE	2000	01.07~07.08	U12T01-COIL	1	EFI	90919-02164

●印：生産終了品

トヨタ
TOYOTA日産
NISSANホンダ
HONDAマツダ
MAZDAスバル
SUBARU三菱
MITSUBISHIスズキ
SUZUKIダイハツ
DAIHATSUいすゞ
ISUZU対照表-1
純正品番順対照表-2
Astemo品番順

車両型式	エンジン 型式	排気量	年式	Astemo品番	使用数	類別内容	適応純正品番 (参考)
------	------------	-----	----	----------	-----	------	----------------

ダイナ/トヨエース

RZY231H	3RZFPE	2700	03.05~07.12	U13T07-COIL	4	LPG	90919-02237
RZY281H	3RZFPE	2700	03.05~07.12	U13T07-COIL	4	LPG	90919-02237
TRC600	2TRFE	2700	11.07~16.05	U13T04-COIL	4	EFI	90919-02260
TRC600A	2TRFE	2700	11.07~15.05	U13T04-COIL	4	EFI	90919-02260
TRU300	2TRFE	2700	07.05~11.06	U13T04-COIL	4	EFI	90919-02248
TRU300A	2TRFE	2700	07.05~11.06	U13T04-COIL	4	EFI	90919-02248
TRU340	2TRFE	2700	07.05~11.06	U13T04-COIL	4	EFI	90919-02248
TRU500	2TRFE	2700	07.05~11.06	U13T04-COIL	4	EFI	90919-02248
TRU600	2TRFE	2700	11.07~16.05	U13T04-COIL	4	EFI	90919-02260
TRY220	1TRFE	2000	03.08~	U13T04-COIL	4	EFI	90919-02248
TRY230	1TRFE	2000	03.08~	U13T04-COIL	4	EFI	90919-02248
YY61	3Y	2000	85.08~95.05	U12T13-COIL	1		90919-02139
YY101	3Y	2000	96.10~01.07	U12T13-COIL	1		90919-02139
YY121	3Y	2000	96.10~01.07	U12T13-COIL	1		90919-02139
YY131	3Y	2000	96.10~01.07	U12T13-COIL	1		90919-02139
YY201	3Y	2000	95.05~01.07	U12T13-COIL	1		90919-02139
YY211	3Y	2000	95.05~01.07	U12T13-COIL	1		90919-02139
	3YP	2000	95.05~01.07	U12T13-COIL	1	LPG	90919-02139

チェイサー

GX100	1GFE	2000	98.08~01.06	U13T02-COIL	6	EFI	90919-02230
GX105	1GFE	2000	98.08~01.06	U13T02-COIL	6	EFI	90919-02230
JZX100	1JZGE	2500	96.09~01.06	U22T01-COIL	3		90919-02216
	1JZGTE	2500	96.09~01.06	U22T01-COIL	3		90919-02216
JZX101	2JZGE	3000	96.09~01.06	U22T01-COIL	3		90919-02216
JZX105	1JZGE	2500	96.09~01.06	U22T01-COIL	3		90919-02216

ツーリングハイエース

RCH41W	3RZFE	2700	99.07~02.05	U13T07-COIL	4		90919-02237
RCH47W	3RZFE	2700	99.07~02.05	U13T07-COIL	4		90919-02237

デュエット

M100A	EJDE	1000	98.09~00.05	U21D01-COIL	3	EFI	90048-52126
	EJVE	1000	00.05~04.05	U21D01-COIL	3	EFI	90048-52126
M101A	K3VE	1300	00.05~04.05	U15D03-COIL	4	EFI	90048-52130
M110A	EJDE	1000	98.09~00.05	U21D01-COIL	3	EFI	90048-52126
	EJVE	1000	00.05~04.05	U21D01-COIL	3	EFI	90048-52126
M111A	K3VE	1300	00.05~04.05	U15D03-COIL	4	EFI	90048-52130

ナディア

ACN10	1AZFSE	2000	01.04~03.07	U13T04-COIL	4		90919-02247
ACN10H	1AZFSE	2000	01.04~03.07	U13T04-COIL	4		90919-02247
ACN15	1AZFSE	2000	02.08~03.07	U13T04-COIL	4		90919-02247
ACN15H	1AZFSE	2000	02.08~03.07	U13T04-COIL	4		90919-02247
SXN10	3SFE	2000	98.07~03.07	U12T18-COIL	1	NO.1,EFI	90919-02217
					1	NO.2,EFI	90919-02218
SXN10H	3SFE	2000	98.07~03.07	U12T18-COIL	1	NO.1,EFI	90919-02217
					1	NO.2,EFI	90919-02218
SXN15	3SFE	2000	98.07~03.07	U12T18-COIL	1	NO.1,EFI	90919-02217
					1	NO.2,EFI	90919-02218
SXN15H	3SFE	2000	98.07~03.07	U12T18-COIL	1	NO.1,EFI	90919-02217
					1	NO.2,EFI	90919-02218

西暦	1994	95	96	97	98	99	2000	01	02	03	04	05	06	07	08	09	10	11	12	13	14	15	16	17	18	19	20	21	22	23	24	25	26
和暦	平成6	7	8	9	10	11	12	13	14	15	16	17	18	19	20	21	22	23	24	25	26	27	28	29	30	令和元年	2	3	4	5	6	7	8

車両型式	エンジン 型式	排気量	年式	Astemo品番	使用数	類別内容	適応純正品番 (参考)
------	------------	-----	----	----------	-----	------	----------------

ノア

AZR60G	1AZFSE	2000	01.11~07.06	U13T04-COIL	4		90919-02260
AZR65G	1AZFSE	2000	01.11~07.06	U13T04-COIL	4		90919-02260
MZRA90	M20AFKS	2000	22.01~	U23T02-COIL	4		90919-02276
MZRA92	M20AFKS	2000	22.01~	U23T02-COIL	4		90919-02276
MZRA95	M20AFKS	2000	22.01~	U23T02-COIL	4		90919-02276
MZRA97	M20AFKS	2000	22.01~	U23T02-COIL	4		90919-02276
ZRR70	3ZRFE	2000	07.06~10.04	U19T14-COIL	4		90919-02258
	3ZRFAE	2000	10.04~14.01	U19T14-COIL	4		90919-02258
ZRR75	3ZRFE	2000	07.06~10.04	U19T14-COIL	4		90919-02258
	3ZRFAE	2000	10.04~14.01	U19T14-COIL	4		90919-02258
ZRR80	3ZRFAE	2000	14.01~21.12	U19T14-COIL	4		90919-02258
ZRR85	3ZRFAE	2000	14.01~21.12	U19T14-COIL	4		90919-02258
ZWR80	2ZRFXE	1800	14.01~21.12	U19T14-COIL	4		90919-02258
ZWR90	2ZRFXE	1800	22.01~	U23T01-COIL	4		90919-02277
ZWR92	2ZRFXE	1800	22.01~	U23T01-COIL	4		90919-02277
ZWR95	2ZRFXE	1800	22.01~	U23T01-COIL	4		90919-02277

ハイエース

RZH100G	1RZE	2000	89.08~95.08	U12T01-COIL	1	EFI	90919-02164
RZH101G	2RZE	2400	89.08~95.08	U12T14-COIL	1	EFI	90919-02163
			95.08~03.08	U12T01-COIL	1	EFI	90919-02164
RZH102V	1RZE	2000	89.08~03.08	U12T01-COIL	1	EFI	90919-02164
RZH110G	1RZE	2000	89.08~93.08	U12T01-COIL	1	EFI	90919-02164
RZH111G	2RZE	2400	95.08~02.08	U12T01-COIL	1	EFI	90919-02164
RZH112K	1RZE	2000	89.08~03.08	U12T01-COIL	1	EFI	90919-02164
RZH112V	1RZE	2000	89.08~03.08	U12T01-COIL	1	EFI	90919-02164
RZH122V	1RZ	2000	89.08~93.08	U12T01-COIL	1		90919-02164
RZH124B	1RZE	2000	89.08~03.08	U12T01-COIL	1	EFI	90919-02164
RZH125B	2RZE	2400	98.08~03.08	U12T01-COIL	1	EFI	90919-02164
RZH133S	2RZE	2400	95.08~99.07	U12T01-COIL	1	EFI	90919-02164
RZH133V	2RZE	2400	95.08~99.07	U12T01-COIL	1	EFI	90919-02164
RZH182K	1RZE	2000	00.12~03.08	U12T01-COIL	1	EFI	90919-02164
RZH183K	2RZE	2400	00.12~03.08	U12T01-COIL	1	EFI	90919-02164
TRH102V	1TRFE	2000	03.08~04.08	U13T04-COIL	4	EFI	90919-02248
TRH112K	1TRFE	2000	03.08~04.08	U13T04-COIL	4	EFI	90919-02248
TRH112V	1TRFE	2000	03.08~04.08	U13T04-COIL	4	EFI	90919-02248
TRH122K	1TRFE	2000	03.08~05.01	U13T04-COIL	4	EFI	90919-02248
TRH124B	1TRFE	2000	03.08~05.01	U13T04-COIL	4	EFI	90919-02248
TRH200K	1TRFE	2000	04.08~	U13T04-COIL	4	EFI	90919-02248
TRH200V	1TRFE	2000	04.08~	U13T04-COIL	4	EFI	90919-02248
TRH211K	2TRFE	2700	07.09~	U13T04-COIL	4	EFI	90919-02248
TRH214W	2TRFE	2700	04.08~	U13T04-COIL	4	EFI	90919-02248
TRH216K	2TRFE	2700	07.09~	U13T04-COIL	4	EFI	90919-02248
TRH219W	2TRFE	2700	04.08~	U13T04-COIL	4	EFI	90919-02248
TRH221K	2TRFE	2700	05.01~	U13T04-COIL	4	EFI	90919-02248
TRH223B	2TRFE	2700	05.01~	U13T04-COIL	4	EFI	90919-02248
TRH224W	2TRFE	2700	05.01~	U13T04-COIL	4	EFI	90919-02248
TRH226K	2TRFE	2700	05.01~	U13T04-COIL	4	EFI	90919-02248
TRH228B	2TRFE	2700	05.01~	U13T04-COIL	4	EFI	90919-02248
TRH229W	2TRFE	2700	05.01~	U13T04-COIL	4	EFI	90919-02248
YY101	3Y	2000	95.05~96.10	U12T13-COIL	1		90919-02139

●印：生産終了品

車両型式	エンジン型式	排気量	年式	Astemo品番	使用数	類別内容	適応純正品番(参考)
------	--------	-----	----	----------	-----	------	------------

ハイラックス

RZN147	1RZE	2000	97.08~03.08	U12T01-COIL	1	EFI	90919-02164
RZN152H	1RZE	2000	99.08~03.08	U12T01-COIL	1	EFI	90919-02164
RZN167	1RZE	2000	97.08~99.08	U12T01-COIL	1	EFI	90919-02164
RZN169H	3RZFE	2700	99.08~04.07	U12T18-COIL	1	NO.1,EFI	90919-02217
					1	NO.2,EFI	90919-02220
RZN174H	3RZFE	2700	99.08~04.07	U12T18-COIL	1	NO.1,EFI	90919-02217
					1	NO.2,EFI	90919-02220
YN100	3Y	2000	88.09~94.08	U12T13-COIL	1		90919-02139
YN105	3Y	2000	88.09~91.08	U12T13-COIL	1		90919-02139
YN107	3Y	2000	91.08~94.08	U12T13-COIL	1		90919-02139
	3YE	2000	94.08~97.08	U12T13-COIL	1	EFI	90919-02139
YN80	2Y	1800	88.09~94.08	U12T13-COIL	1		90919-02139
YN81	3YE	2000	94.08~97.08	U12T13-COIL	1	EFI	90919-02139
YN85	2Y	1800	88.09~94.08	U12T13-COIL	1		90919-02139
YN86	3YE	2000	94.08~97.08	U12T13-COIL	1	EFI	90919-02139

ハイラックスサーフ

GRN215W	1GRFE	4000	05.08~09.08	U13T04-COIL	6	EFI	90919-02248
RZN180W	3RZFE	2700	95.11~00.08	U12T14-COIL	1	EFI	90919-02163
			00.08~02.11	U13T07-COIL	4	EFI	90919-02237
RZN185W	3RZFE	2700	95.11~00.08	U12T14-COIL	1	EFI	90919-02163
			00.08~02.11	U13T07-COIL	4	EFI	90919-02237
RZN210W	3RZFE	2700	02.11~04.08	U13T07-COIL	4	EFI	90919-02237
RZN215W	3RZFE	2700	02.11~04.08	U13T07-COIL	4	EFI	90919-02237
TRN210W	2TRFE	2700	04.08~09.08	U13T04-COIL	4	EFI	90919-02248
TRN215W	2TRFE	2700	04.08~09.08	U13T04-COIL	4	EFI	90919-02248
VZN130G	3VZE	3000	91.08~95.11	U12T02-COIL	1	EFI	90919-02197
YN130G	3YE	2000	89.04~91.08	U12T12-COIL	1	EFI	90919-02135

ハリアー/ハリアー ハイブリッド

ACU10W	2AZFE	2400	00.11~03.02	U13T03-COIL	4	EFI	90919-02243
ACU15W	2AZFE	2400	00.11~03.02	U13T03-COIL	4	EFI	90919-02243
ACU30W	2AZFE	2400	03.02~12.07	U13T03-COIL	4	EFI	90919-02243
ACU35W	2AZFE	2400	03.02~12.07	U13T03-COIL	4	EFI	90919-02243
ASU60	8ARFTS	2000	17.05~	U23T03-COIL	4		90919-02269
ASU65	8ARFTS	2000	17.05~	U23T03-COIL	4		90919-02269
AVU65W	2ARFXE	2500	13.11~20.05	U13T06-COIL	4	EFI	90919-02256
AXUH80	A25AFXS	2500	20.06~	U23T01-COIL	4		90919-02277
AXUH85	A25AFXS	2500	20.06~	U23T01-COIL	4		90919-02277
AXUP85	A25AFXS	2500	22.10~	U23T01-COIL	4		90919-02277
GSU30W	2GRFE	3500	06.01~08.12	U19T15-COIL	6	2WD	90919-02251
GSU31W	2GRFE	3500	06.01~08.12	U19T15-COIL	6	2WD	90919-02251
GSU35W	2GRFE	3500	06.01~08.12	U19T15-COIL	6	4WD	90919-02251
GSU36W	2GRFE	3500	06.01~08.12	U19T15-COIL	6	4WD	90919-02251
MCU10	1MZFE	3000	97.12~03.02	U19T11-COIL	6		90919-02234
MCU15	1MZFE	3000	97.12~03.12	U19T11-COIL	6		90919-02234
MCU30	1MZFE	3000	03.02~06.01	U19T11-COIL	6		90919-02234
MCU31	1MZFE	3000	03.02~06.01	U19T11-COIL	6		90919-02234
MCU35	1MZFE	3000	03.02~06.01	U19T11-COIL	6		90919-02234
MCU36	1MZFE	3000	03.02~06.01	U19T11-COIL	6		90919-02234
MXUA80	M20AFKS	2000	20.06~	U23T02-COIL	4		90919-02276
MXUA85	M20AFKS	2000	20.06~	U23T02-COIL	4		90919-02276

西暦	1994	95	96	97	98	99	2000	01	02	03	04	05	06	07	08	09	10	11	12	13	14	15	16	17	18	19	20	21	22	23	24	25	26
和暦	平成6	7	8	9	10	11	12	13	14	15	16	17	18	19	20	21	22	23	24	25	26	27	28	29	30	令和元年	2	3	4	5	6	7	8

車両型式	エンジン 型式	排気量	年 式	Astemo品番	使用数	類 別 内 容	適応純正品番 (参考)
------	------------	-----	-----	----------	-----	---------	----------------

ハリアー/ハリアー ハイブリッド

SXU10W	5SFE	2200	97.12~00.11	U12T18-COIL	1	NO.1,EFI	90919-02217
					1	NO.2,EFI	90919-02218
SXU15W	5SFE	2200	97.12~00.11	U12T18-COIL	1	NO.1,EFI	90919-02217
					1	NO.2,EFI	90919-02218
ZSU60	3ZRFAE	2000	13.12~20.05	U19T14-COIL	4		90919-02258
ZSU65	3ZRFAE	2000	13.12~20.05	U19T14-COIL	4		90919-02258

パッソ

KGC10	1KRFE	1000	04.05~10.02	U13T05-COIL	3	EFI	90919-02239
QNC10	K3VE	1300	05.04~10.02	U20T02-COIL	4	EFI	19070-B1011
KGC15	1KRFE	1000	04.05~10.02	U13T05-COIL	3	EFI	90919-02239
KGC30	1KRFE	1000	10.02~16.04	U18D04-COIL	3	EFI	19500-B2050
KGC30	1KRFE	1000	14.04~	U23T04-COIL	3		90919-02270
KGC35	1KRFE	1000	10.02~16.04	U18D04-COIL	3	EFI	19500-B2050
KGC35	1KRFE	1000	14.04~	U23T04-COIL	3		90919-02270
M700A	1KR-FE	1000	16.04~	U22T02-COIL	3		90919-02281
M710A	1KR-FE	1000	16.04~	U22T02-COIL	3		90919-02281

ビスタ

AZV50	1AZFSE	2000	01.08~03.07	U13T04-COIL	4		90919-02247
AZV55	1AZFSE	2000	02.04~03.07	U13T04-COIL	4		90919-02248
SV55	3SFE	2000	98.06~02.04	U12T18-COIL	1	NO.1,EFI	90919-02217
					1	NO.2,EFI	90919-02218
ZZV50	1ZZFE	1800	00.04~03.07	U13T05-COIL	4	EFI	90919-02239

ビスタ アルディオ

AZV50G	1AZFSE	2000	01.08~03.07	U13T04-COIL	4		90919-02247
AZV55G	1AZFSE	2000	02.04~03.07	U13T04-COIL	4		90919-02248
SV55G	3SFE	2000	98.06~03.07	U12T18-COIL	1	NO.1,EFI	90919-02217
					1	NO.2,EFI	90919-02218
ZZV50G	1ZZFE	1800	00.04~03.07	U13T05-COIL	4	EFI	90919-02239

ピクシス

S201U	KFVE	660	11.12~14.07	U18D04-COIL	3	EFI	19500-B2050
S211U	KFVE	660	11.12~14.07	U18D04-COIL	3	EFI	19500-B2050
S321M	KFDET	660	11.12~21.12	U18D04-COIL	3	EFI	19500-B2050
					3		19500-B2050
S331M	KFDET	660	11.12~21.12	U18D04-COIL	3	EFI	19500-B2050
					3		19500-B2050
S500U	KFVE	660	14.09~21.12	U18D04-COIL	3	EFI	19500-B2050
			21.12~	U24D01-COIL	3		19500-B2070
			20.09~	U18D04-COIL	3		19500-B2050
S510U	KFVE	660	14.09~21.12	U18D04-COIL	3	EFI	19500-B2050
			21.12~	U24D01-COIL	3		19500-B2070
			20.09~	U18D04-COIL	3		19500-B2050
S700M	KFVE	660	21.12~	U24D01-COIL	3		19500-B2070
							19500-B2070
S710M	KFVE	660	21.12~	U24D01-COIL	3		19500-B2070
							19500-B2070

●印：生産終了品

車両型式	エンジン型式	排気量	年式	Astemo品番	使用数	類別内容	適応純正品番 (参考)
------	--------	-----	----	----------	-----	------	----------------

ピクシス エポック

LA300A	KFVE	660	12.04~17.04	U18D04-COIL	3	EFI	19500-B2050
LA310A	KFVE	660	12.04~17.04	U18D04-COIL	3	EFI	19500-B2050
LA350A	KFVE	660	17.05~	U18D04-COIL	3	EFI	19500-B2050
LA360A	KFVE	660	17.05~	U18D04-COIL	3	EFI	19500-B2050

ピクシス ジョイ

LA250A	KFVE	660	16.09~23.06	U18D04-COIL	3	EFI	19500-B2050
	KFVET	660	16.09~23.06	U18D04-COIL	3	EFI	19500-B2050
LA260A	KFVE	660	16.09~23.06	U18D04-COIL	3	EFI	19500-B2050
	KFVET	660	16.09~23.06	U18D04-COIL	3	EFI	19500-B2050

ピクシス メガ

LA700A	KFVE	660	15.07~22.08	U18D04-COIL	3	EFI	19500-B2050
	KFVET	660	15.07~22.08	U18D04-COIL	3	TURBO	19500-B2050
LA710A	KFVE	660	15.07~22.08	U18D04-COIL	3	EFI	19500-B2050
	KFVET	660	15.07~22.08	U18D04-COIL	3	TURBO	19500-B2050

ピクシス スペース

L575A	KFVE	660	11.09~17.01	U18D04-COIL	3	EFI	19500-B2050
	KFDET	660	11.09~17.01	U18D04-COIL	3	TURBO	19500-B2050
L585A	KFVE	660	11.09~17.01	U18D04-COIL	3	EFI	19500-B2050
	KFDET	660	11.09~17.01	U18D04-COIL	3	TURBO	19500-B2050

ファンカーゴ

NCP20	2NZFE	1300	99.08~05.09	U13T01-COIL	4	EFI	90919-02240
NCP21	1NZFE	1500	99.08~05.09	U13T01-COIL	4	EFI	90919-02240
NCP25	1NZFE	1500	99.08~05.09	U13T01-COIL	4	EFI	90919-02240

ブレイド

AZE154H	2AZFE	2400	06.12~07.02	U13T04-COIL	4	EFI	90919-02248
			09.12~12.04	U13T04-COIL	4	EngineNo=CXXXXXX-GXXXXXX,EFI	90919-C2002
			10.11~12.04	U13T03-COIL	4	EngineNo=OXXXXXX-6XXXXXX, BXXXXXX,HXXXXXX-KXXXXXX, MARK 90919,EFI	90919-02244
			10.12~12.04	U13T04-COIL	4	EngineNo=CXXXXXX-GXXXXXX, MARK 02260,EFI	90919-02260
AZE156H	2AZFE	2400	06.12~07.02	U13T04-COIL	4	EFI	90919-02248
			09.12~12.04	U13T04-COIL	4	EngineNo=CXXXXXX-GXXXXXX, EFI	90919-C2002
			10.11~12.04	U13T03-COIL	4	EngineNo=OXXXXXX-6XXXXXX, BXXXXXX,HXXXXXX-KXXXXXX, MARK 90919,EFI	90919-02244
			10.12~12.04	U13T04-COIL	4	EngineNo=CXXXXXX-GXXXXXX, MARK 02260,EFI	90919-02260
GRE156H	2GRFE	3500	07.08~12.04	U19T15-COIL	6	2WD	90919-02251

プラッツ

NCP12	1NZFE	1500	99.08~05.12	U13T01-COIL	4	EFI	90919-02240
NCP16	2NZFE	1300	99.08~05.12	U13T01-COIL	4	EFI	90919-02240
SCP11	1SZFE	1000	99.08~05.12	U13T01-COIL	4	EFI	90919-02229

西暦	1994	95	96	97	98	99	2000	01	02	03	04	05	06	07	08	09	10	11	12	13	14	15	16	17	18	19	20	21	22	23	24	25	26
和暦	平成6	7	8	9	10	11	12	13	14	15	16	17	18	19	20	21	22	23	24	25	26	27	28	29	30	令和元年	2	3	4	5	6	7	8

車両型式	エンジン 型式	排気量	年 式	Astemo品番	使用数	類 別 内 容	適応純正品番 (参考)
------	------------	-----	-----	----------	-----	---------	----------------

プリウス

MXWH60	M20AFXS	2000	22.12~	U23T01-COIL	4		90919-02277
MXWH61	M20AFXS	2000	22.12~	U23T01-COIL	4		90919-02277
MXWH65	M20AFXS	2000	22.12~	U23T01-COIL	4		90919-02277
NHW10	1NZFXE	1500	97.12~00.05	U13T01-COIL	4	EFI	90919-02229
NHW11	1NZFXE	1500	00.05~03.08	U13T01-COIL	4	EFI	90919-02240
NHW20	1NZFXE	1500	03.08~10.10	U13T01-COIL	4	EFI	90919-02240
			10.10~11.12	U13T08-COIL	4	EFI	90919-02265
ZVW30	2ZRFXE	1800	09.04~15.11	U19T14-COIL	4		90919-02258
ZVW50	2ZRFXE	1800	15.11~18.12	U21T01-COIL	4	EFI	90919-02272
ZVW51	2ZRFXE	1800	15.11~18.12	U21T01-COIL	4	EFI	90919-02272
ZVW52	2ZRFXE	1800	16.09~	U21T01-COIL	4	EFI,PHV	90919-02272
ZVW55	2ZRFXE	1800	15.11~	U21T01-COIL	4	EFI	90919-02272
ZVW60	2ZRFXE	1800	22.12~	U23T01-COIL	4		90919-02277
ZVW65	2ZRFXE	1800	22.12~	U23T01-COIL	4		90919-02277

プリウスPHV

ZVW35	2ZRFXE	1800	09.12~16.04	U19T14-COIL	4		90919-02258
-------	--------	------	-------------	-------------	---	--	-------------

プリウスα

ZVW40	2ZRFXE	1800	12.10~21.03	U19T14-COIL	4		90919-02258
ZVW41	2ZRFXE	1800	11.04~21.03	U19T14-COIL	4		90919-02258

プログレス

JCG10	1JZGE	2500	98.05~01.04	U22T01-COIL	3		90919-02216
JCG11	2JZGE	3000	98.05~01.04	U22T01-COIL	3		90919-02216
JCG15	1JZGE	2500	98.05~01.04	U22T01-COIL	3		90919-02216

プロナード

MCX20	1MZFE	3000	00.02~03.01	U19T11-COIL	6		90919-02234
-------	-------	------	-------------	-------------	---	--	-------------

プロボックス

NCP160V	1NZFE	1500	14.09~	U13T04-COIL	4	EFI	90919-02260
NCP165V	1NZFE	1500	14.09~	U13T04-COIL	4	EFI	90919-02260
NCP50V	2NZFE	1300	02.06~10.10	U13T01-COIL	4	EFI	90919-02240
			10.10~14.09	U13T08-COIL	4	EFI	90919-02265
NCP51V	1NZFE	1500	02.06~10.10	U13T01-COIL	4	EFI	90919-02240
			10.10~14.09	U13T08-COIL	4	EFI	90919-02265
NCP52V	1NZFNE	1500	02.06~10.10	U13T01-COIL	4	CNG	90919-02240
			10.10~14.09	U13T08-COIL	4	CNG	90919-02265
NCP55V	1NZFE	1500	02.06~10.10	U13T01-COIL	4	EFI	90919-02240
			10.10~14.09	U13T08-COIL	4	EFI	90919-02265
NCP58G	1NZFE	1500	02.06~10.10	U13T01-COIL	4	EFI	90919-02240
			10.10~13.10	U13T08-COIL	4	EFI	90919-02265
NCP59G	1NZFE	1500	02.06~10.10	U13T01-COIL	4	EFI	90919-02240
			10.10~13.10	U13T08-COIL	4	EFI	90919-02265
NSP160V	1NRFE	1300	14.09~	U20T03-COIL	4	2WD	90919-02257

トヨタ

TOYOTA

車両型式	エンジン型式	排気量	年式	Astemo品番	使用数	類別内容	適応純正品番(参考)
------	--------	-----	----	----------	-----	------	------------

ベルタ

KSP92	1KRFE	1000	05.11~12.06	U13T05-COIL	3	EFI	90919-02239
NCP96	2NZFE	1300	05.11~10.10	U13T01-COIL	4	EFI	90919-02240
			10.10~12.06	U13T08-COIL	4	EFI	90919-02265
SCP92	2SZFE	1300	05.11~10.05	U13T01-COIL	4	EFI	90919-02240
			10.05~12.06	U13T08-COIL	4	EFI	90919-02265

ポルテ

NCP141	1NZFE	1500	12.07~15.07	U13T04-COIL	4	EFI	90919-02260
NCP145	1NZFE	1500	12.07~	U13T04-COIL	4	EFI	90919-02260
NNP10	2NZFE	1300	04.07~10.10	U13T01-COIL	4	EFI	90919-02240
			10.10~12.07	U13T08-COIL	4	EFI	90919-02265
NNP11	1NZFE	1500	04.07~10.10	U13T01-COIL	4	EFI	90919-02240
			10.10~12.07	U13T08-COIL	4	EFI	90919-02265
NNP15	1NZFE	1500	06.01~10.10	U13T01-COIL	4	EFI	90919-02240
			10.10~12.07	U13T08-COIL	4	EFI	90919-02265
NSP140	1NRFE	1300	12.07~15.07	U20T03-COIL	4	2WD	90919-02257
NSP141	2NRFKE	1500	15.07~	U20T03-COIL	4	2WD	90919-02257

マークII

GX100	1GFE	2000	98.08~00.10	U13T02-COIL	6	EFI	90919-02230
GX105	1GFE	2000	98.08~00.10	U13T02-COIL	6	EFI	90919-02230
GX110	1GFE	2000	00.10~04.11	U13T02-COIL	6	EFI	90919-02230
GX115	1GFE	2000	00.10~04.11	U13T02-COIL	6	EFI	90919-02230
JZX90	1JZGE	2500	92.10~96.09	U12T02-COIL	1	ハートトップ, ガラテ, AT	90919-02197
JZX91	2JZGE	3000	92.10~96.09	U12T02-COIL	1	ハートトップ, ガラテ G	90919-02197
JZX93	1JZGE	2500	93.10~96.09	U12T02-COIL	1	ハートトップ, AT	90919-02197
JZX100	1JZGE	2500	96.09~00.10	U22T01-COIL	3		90919-02216
	1JZGTE	2500	96.09~00.10	U22T01-COIL	3		90919-02216
JZX101	2JZGE	3000	96.09~00.10	U22T01-COIL	3		90919-02216
JZX105	1JZGE	2500	96.09~00.10	U22T01-COIL	3		90919-02216
JZX110	1JZGTE	2500	00.10~04.11	U22T01-COIL	3		90919-02216
JZX115	1JZGE	2500	00.10~04.11	U22T01-COIL	3		90919-02216
SX90	4SFE	1800	92.10~96.09	U12T02-COIL	1	ハートトップ	90919-02197
YX78V	3YE	2000	93.02~95.09	U12T12-COIL	1	ハ, GL, EFI	90919-02135
		2000	95.09~97.04	U12T13-COIL	1	ハ, GL, EFI	90919-02139
YX80	3YP	2000	88.08~95.12	U12T13-COIL	1	セ, LPG	90919-02139
YX80Y	3YP	2000	88.08~95.12	U12T13-COIL	1	セ, 教習車, LPG	90919-02139

マークII クオリス

MCV20	1MZFE	3000	99.08~01.12	U19T11-COIL	6		90919-02234
SXV20W	5SFE	2200	97.04~01.12	U12T18-COIL	1	NO.1, EFI	90919-02217
					1	NO.2, EFI	90919-02218
SXV25W	5SFE	2200	97.04~01.12	U12T18-COIL	1	NO.1, EFI	90919-02217
					1	NO.2, EFI	90919-02218

マークII ブリット

JZX110	1JZGTE	2500	00.10~04.11	U22T01-COIL	3		90919-02216
JZX115	1JZGE	2500	00.10~04.11	U22T01-COIL	3		90919-02216
GX110W	1GFE	2000	02.01~07.06	U13T02-COIL	6	EFI	90919-02230
GX115W	1GFE	2000	02.01~07.06	U13T02-COIL	6	EFI	90919-02230

西暦	1994	95	96	97	98	99	2000	01	02	03	04	05	06	07	08	09	10	11	12	13	14	15	16	17	18	19	20	21	22	23	24	25	26
和暦	平成6	7	8	9	10	11	12	13	14	15	16	17	18	19	20	21	22	23	24	25	26	27	28	29	30	令和元年	2	3	4	5	6	7	8

TOYOTA
トヨタNISSAN
日産HONDA
ホンダMAZDA
マツダSUBARU
スバルMITSUBISHI
三菱SUZUKI
スズキDAIHATSU
ダイハツISUZU
いすゞ純正品番
対照表-1Astemo品番
対照表-2

トヨタ

TOYOTA

車両型式	エンジン 型式	排気量	年 式	Astemo品番	使用数	類 別 内 容	適応純正品番 (参考)
------	------------	-----	-----	----------	-----	---------	----------------

マークX

GRX120	4GRFSE	2500	04.11~09.09	U13T06-COIL	6		90919-02250
GRX121	3GRFSE	3000	04.11~09.09	U13T06-COIL	6		90919-02250
GRX125	4GRFSE	2500	04.11~09.09	U13T06-COIL	6		90919-02250
GRX130	4GRFSE	2500	09.10~19.12	U13T06-COIL	6		90919-02256
GRX133	2GRFSE	3500	09.10~16.04	U13T06-COIL	6		90919-02256
GRX133	2GRFSE	3500	15.10~	U23T05-COIL	6		90919-02273
GRX135	4GRFSE	2500	09.10~19.12	U13T06-COIL	6		90919-02256

マークX ジオ

ANA10	2AZFE	2400	07.09~13.10	U13T04-COIL	4	EngineNo=CXXXXXX-GXXXXXX, MARK C2002,02260,C2###, T2###,EFI	90919-C2006
			11.01~13.10	U13T03-COIL	4	EngineNo=OXXXXXX-6XXXXXX, BXXXXXX,HXXXXXX-KXXXXXX, MARK 90919,EFI	90919-02244
ANA15	2AZFE	2400	07.09~13.10	U13T04-COIL	4	EngineNo=CXXXXXX-GXXXXXX, MARK C2002,02260,C2###, T2###,EFI	90919-C2006
			11.01~13.10	U13T03-COIL	4	EngineNo=OXXXXXX-6XXXXXX, BXXXXXX,HXXXXXX-KXXXXXX, MARK 90919,EFI	90919-02244
GGA10	2GRFE	3500	07.09~13.10	U19T15-COIL	6	2WD	90919-02251

ライズ

A200A	1KR-VET	1000	19.10~21.11	U22T02-COIL	3		90919-02281
A210A	1KR-VET	1000	19.10~	U22T02-COIL	3		90919-02281

ライトエース/タウンエース/マスターエース

S402M	3SZVE	1500	08.01~20.07	U21T04-COIL	4		19070-BZ031
YM55	2Y	1800	86.10~99.06	U12T13-COIL	1		90919-02139
YM60	2Y	1800	86.10~99.06	U12T13-COIL	1		90919-02139
YM65	2Y	1800	90.08~99.06	U12T13-COIL	1		90919-02139
YR21G	3YEY	2000	92.01~95.08	U12T12-COIL	1	EFI	90919-02135
			95.08~96.10	U12T13-COIL	1	EFI	90919-02139
YR25V	2YJ	1800	92.01~96.10	U12T13-COIL	1		90919-02139
YR30G	3YEY	2000	92.01~95.08	U12T12-COIL	1	EFI	90919-02135
			95.08~96.10	U12T13-COIL	1	EFI	90919-02139

ラウム

EXZ10	5EFE	1500	97.05~03.04	U12T18-COIL	1	NO.2,3,EFI	90919-02220
EXZ15	5EFE	1500	97.05~03.04	U12T18-COIL	1	NO.2,3,EFI	90919-02220
NCZ20	1NZFE	1500	03.04~10.10	U13T01-COIL	4	EFI	90919-02240
			10.10~11.04	U13T08-COIL	4	EFI	90919-02265
NCZ25	1NZFE	1500	03.04~10.10	U13T01-COIL	4	EFI	90919-02240
			10.10~11.04	U13T08-COIL	4	EFI	90919-02265

●印：生産終了品

トヨタ

TOYOTA

車両型式	エンジン型式	排気量	年式	Astemo品番	使用数	類別内容	適応純正品番(参考)
------	--------	-----	----	----------	-----	------	------------

ラクティス

NCP100	1NZFE	1500	05.09~10.11	U13T04-COIL	4	EFI	90919-02248
NCP105	1NZFE	1500	05.09~10.11	U13T01-COIL	4	EFI	90919-02240
NCP120	1NZFE	1500	10.11~16.07	U13T04-COIL	4	EFI	90919-02260
NCP125	1NZFE	1500	10.11~16.07	U13T04-COIL	4	EFI	90919-02260
NSP120	1NRFKE	1300	10.11~14.05	U20T03-COIL	4	2WD	90919-02257
	1NRFKE	1300	14.05~16.07	U20T03-COIL	4	2WD	90919-02257
NSP122	1NRFKE	1300	10.11~14.05	U20T03-COIL	4	2WD	90919-02257
	1NRFKE	1300	14.05~16.07	U20T03-COIL	4	2WD	90919-02257
SCP100	2SZFE	1300	05.09~10.05	U13T01-COIL	4	EFI	90919-02240
			10.05~10.11	U13T08-COIL	4	EFI	90919-02265

ラッシュ

F700	3SZVE	1500	06.12~17.11	U21T04-COIL	4		19070-BZ031
J200E	3SZVE	1500	06.01~10.07	U20T02-COIL	4	2WD,EFI	19070-B1011
J210E	3SZVE	1500	06.01~10.07	U20T02-COIL	4	4WD,EFI	19070-B1011

ランドクルーザー

GRJ76K	1GRFE	4000	14.08~15.07	U13T04-COIL	6	EFI	90919-02260
GRJ79K	1GRFE	4000	14.08~15.07	U13T04-COIL	6	EFI	90919-02260
URJ202W	1URFE	4600	09.05~	U13T06-COIL	8	EFI	90919-02250
UZJ100W	2UZFE	4700	98.01~03.08	U13T02-COIL	8	EFI	90919-02230
VJA300	V35AFTS	3500	21.07~	U23T01-COIL	6		90919-02277

ランドクルーザー プラド

GRJ120W	1GRFE	4000	05.08~09.09	U13T04-COIL	6	EFI	90919-02248
GRJ121W	1GRFE	4000	05.08~09.09	U13T04-COIL	6	EFI	90919-02248
GRJ150W	1GRFE	4000	09.08~15.06	U13T06-COIL	6	EFI	90919-02256
GRJ151W	1GRFE	4000	09.08~15.06	U13T06-COIL	6	EFI	90919-02256
RZJ120W	3RZFE	2700	02.09~04.08	U13T07-COIL	4	EFI	90919-02237
RZJ125W	3RZFE	2700	02.09~04.08	U13T07-COIL	4	EFI	90919-02237
RZJ90W	3RZFE	2700	97.04~02.09	U12T14-COIL	1	EFI	90919-02163
RZJ95W	3RZFE	2700	96.04~02.09	U12T14-COIL	1	EFI	90919-02163
TRJ120W	2TRFE	2700	04.08~09.09	U13T04-COIL	4	EFI	90919-02248
TRJ125W	2TRFE	2700	04.08~09.09	U13T04-COIL	4	EFI	90919-02248
TRJ150W	2TRFE	2700	09.08~	U13T04-COIL	4	EFI	90919-02248

レジアス

RCH41W	3RZFE	2700	97.04~99.07	U12T14-COIL	1	EFI	90919-02163
			99.07~02.05	U13T07-COIL	4	EFI	90919-02237
RCH42V	1RZE	2000	97.06~02.05	U12T01-COIL	1	EFI	90919-02164
RCH47W	3RZFE	2700	97.04~99.07	U12T14-COIL	1	EFI	90919-02163
			99.07~02.05	U13T07-COIL	4	EFI	90919-02237

レジアスエース

RZH112K	1RZE	2000	99.07~03.08	U12T01-COIL	1	EFI	90919-02164
RZH112V	1RZE	2000	99.07~03.08	U12T01-COIL	1	EFI	90919-02164
RZH182K	1RZE	2000	00.12~03.08	U12T01-COIL	1	EFI	90919-02164
RZH183K	2RZE	2400	00.12~03.08	U12T01-COIL	1	EFI	90919-02164
TRH102V	1TRFE	2000	03.08~04.08	U13T04-COIL	4		90919-02260
TRH112V	1TRFE	2000	03.08~04.08	U13T04-COIL	4		90919-02260
TRH112K	1TRFE	2000	03.08~04.08	U13T04-COIL	4	EFI	90919-02248
TRH122K	1TRFE	2000	03.03~05.01	U13T04-COIL	4		90919-02260

西暦	1994	95	96	97	98	99	2000	01	02	03	04	05	06	07	08	09	10	11	12	13	14	15	16	17	18	19	20	21	22	23	24	25	26
和暦	平成6	7	8	9	10	11	12	13	14	15	16	17	18	19	20	21	22	23	24	25	26	27	28	29	30	令和元年	2	3	4	5	6	7	8

TOYOTA
トヨタ

NISSAN
日産

HONDA
ホンダ

MAZDA
マツダ

SUBARU
スバル

MITSUBISHI
三菱

SUZUKI
スズキ

DAIHATSU
ダイハツ

ISUZU
いすゞ

純正品番
対照表-1

Astemo品番
対照表-2

トヨタ

TOYOTA

車両型式	エンジン 型式	排気量	年 式	Astemo品番	使用数	類 別 内 容	適応純正品番 (参考)
------	------------	-----	-----	----------	-----	---------	----------------

レジアスエース

TRH200K	1TRFE	2000	04.08~	U13T04-COIL	4		90919-02260
TRH200V	1TRFE	2000	04.08~	U13T04-COIL	4		90919-02260
TRH211K	2TRFE	2700	07.09~	U13T04-COIL	4		90919-02260
TRH216K	2TRFE	2700	07.09~	U13T04-COIL	4		90919-02260
TRH221K	2TRFE	2700	05.01~	U13T04-COIL	4		90919-02260
TRH223B	2TRFE	2700	05.01~	U13T04-COIL	4	バス	90919-02260
TRH226K	2TRFE	2700	05.01~	U13T04-COIL	4		90919-02260
TRH228B	2TRFE	2700	05.01~	U13T04-COIL	4	バス	90919-02260

ヤリス

KSP210	1KRFE	1000	20.02~	U23T04-COIL	3		90919-02270
MXPA10	M15AFKS	1500	20.02~24.01	U23T01-COIL	3		90919-02277
MXPA15	M15AFKS	1500	20.02~24.01	U23T01-COIL	3		90919-02277
MXPH10	M15AFXE	1500	20.02~	U23T01-COIL	3		90919-02277
MXPH15	M15AFXE	1500	20.02~	U23T01-COIL	3		90919-02277
MXPH14	M15AFXE	1500	24.01~	U23T01-COIL	3		90919-02277
MXPH17	M15AFXE	1500	24.01~	U23T01-COIL	3		90919-02277

ヤリス クロス

MXPB10	M15AFKS	1500	20.08~24.01	U23T01-COIL	3		90919-02277
MXPB15	M15AFKS	1500	20.08~24.01	U23T01-COIL	3		90919-02277
MXPJ10	M15AFXE	1500	20.08~	U23T01-COIL	3		90919-02277
MXPJ15	M15AFXE	1500	20.08~	U23T01-COIL	3		90919-02277

トヨタ
TOYOTA日産
NISSANホンダ
HONDAマツダ
MAZDAスバル
SUBARU三菱
MITSUBISHIスズキ
SUZUKIダイハツ
DAIHATSUいすゞ
ISUZU対照表-1
純正品番順対照表-2
Astemo品番順

●印：生産終了品

日産

NISSAN

車両型式	エンジン型式	排気量	年式	Astemo品番	使用数	類別内容	適応純正品番(参考)
------	--------	-----	----	----------	-----	------	------------

AD

VAY12	CR12DE	1200	06.12~13.05	U08108-COIL	4	EGI	22448-AX001
VFY11	QG15DE	1500	99.06~00.10	U08001-COIL	4	EGI	22448-4M500
			00.10~08.12	U08101-COIL	4	EGI	22448-6N000
VGY11	QG18DN	1800	00.01~08.10	U08001-COIL	4	CNG	22448-4M500
VHNY11	QG18DE	1800	99.06~00.10	U08001-COIL	4	EGI	22448-4M500
			00.10~08.12	U08101-COIL	4	EGI	22448-6N000
VY11	QG13DE	1300	99.06~00.10	U08001-COIL	4	L-Engine HITACHI CM11-205,EGI	22448-4M500
			00.10~07.01	U08101-COIL	4	除く(L-Engine HANSHIN AIC-4004G,EGI)	22448-6N000
VY12	HR15DE	1500	06.12~16.11	U13N04-COIL	4	EGI	22448-ED000
VZNY12	HR16DE	1600	08.12~16.11	U13N04-COIL	4	EGI	22448-JA00C

AD エキスパート

VJY12	MR18DE	1800	06.12~16.11	U15N01-COIL	4	EGI	22448-ED800
VY12	HR15DE	1500	06.12~16.11	U13N04-COIL	4	EGI	22448-ED000
VZNY12	HR16DE	1600	08.12~16.11	U13N04-COIL	4	EGI	22448-JA00C

GT-R

R35	VR38DETT	3800	07.11~19.10	U18N02-COIL	6		22448-JF00B
-----	----------	------	-------------	-------------	---	--	-------------

NT100 クリッパー

DR16T	R06A	660	13.12~	U19S01-COIL	3		22448-4A01A
DR17V	R06A	660	15.03~	U19S01-COIL	3		22448-4A01A
DR17W	R06A	660	15.03~	U19S01-COIL	3		22448-4A01A

NV100 クリッパー/クリッパー リオ

DR17V	R06A	660	15.03~	U19S01-COIL	3	EPI,TURBO	22448-4A01A
DR17W	R06A	660	15.03~	U19S01-COIL	3	TURBO	22448-4A01A
DR64V	K6A	660	13.12~15.03	U21S02-COIL (●U12S01-COIL)	3	EPI,TURBO	22462-4A00A
DR64W	K6A	660	13.12~15.03	U21S02-COIL (●U12S01-COIL)	3	TURBO	22462-4A00A
U71V	3G83	660	03.10~12.01	U11C01-COIL	3	TURBO	22462-6A0AO
			03.10~	U21C01-COIL	3		22462-6A00C
U72V	3G83	660	03.10~12.01	U11C01-COIL	3	TURBO	22462-6A0AO

NV200 バネット

M20	HR16DE	1600	09.05~19.12	U13N04-COIL	4	EGI	22448-JA00C
VM20	HR16DE	1600	09.05~19.12	U13N04-COIL	4	EGI	22448-JA00C

NV350 キャラバン

CS4E26	QR25DE	2500	12.06~	U13N04-COIL	4	EGI	22448-JA00C
DS4E26	QR25DE	2500	12.12~	U13N04-COIL	4	EGI	22448-JA00C
KS2E26	QR25DE	2500	12.06~	U13N04-COIL	4	EGI	22448-JA00C
KS4E26	QR25DE	2500	12.06~	U13N04-COIL	4	EGI	22448-JA00C
VR2E26	QR20DE	2000	12.06~	U13N04-COIL	4	EGI	22448-JA00C

西暦	1994	95	96	97	98	99	2000	01	02	03	04	05	06	07	08	09	10	11	12	13	14	15	16	17	18	19	20	21	22	23	24	25	26
和暦	平成6	7	8	9	10	11	12	13	14	15	16	17	18	19	20	21	22	23	24	25	26	27	28	29	30	令和元年	2	3	4	5	6	7	8

TOYOTA
トヨタ

NISSAN
日産

HONDA
ホンダ

MAZDA
マツダ

SUBARU
スバル

MITSUBISHI
三菱

SUZUKI
スズキ

DAIHATSU
ダイハツ

ISUZU
いすゞ

純正品番順
対照表-1

Astemo品番順
対照表-2

日産

NISSAN

車両型式	エンジン型式	排気量	年式	Astemo品番	使用数	類別内容	適応純正品番 (参考)
------	--------	-----	----	----------	-----	------	----------------

X-TRAIL

HNT32	MR20DD	2000	15.04~	U17N01-COIL	4	DI,CVT	22448-1KCOA
HT32	MR20DD	2000	15.04~	U17N01-COIL	4	DI,CVT	22448-1KCOA
NT30	QR20DE	2000	00.10~07.08	U08103-COIL	4	EGI	22448-8H310
NT31	MR20DE	2000	07.08~14.04	U13N04-COIL	4	EGI	22448-JA00C
NT32	MR20DD	2000	13.12~	U17N01-COIL	4	DI,CVT	22448-1KCOA
PNT30	SR20VET	2000	00.10~07.08	U09123-COIL	4	TURBO	22448-91FOO
SNT33	KR15DDT +BM46 +MM48	1500	22.07~	U24N03-COIL	3		22448-6RCOC
T30	QR20DE	2000	00.10~07.08	U08103-COIL	4	EGI	22448-8H300
T31	MR20DE	2000	07.08~14.04	U13N04-COIL	4	EGI	22448-JA00C
T32	MR20DD	2000	13.12~	U17N01-COIL	4	DI,CVT	22448-1KCOA
T33	KR15DDT +BM46	1500	22.07~	U24N03-COIL	3		22448-6RCOC
TNT31	QR25DE	2500	07.08~14.04	U13N04-COIL	4	EGI	22448-JA00C

アトラス/コンドル

NSQ1F24	QR20DE	2000	07.06~	U13N04-COIL	4	EGI	22448-JA00C
NSQ2F24	QR20DE	2000	07.06~	U13N04-COIL	4	EGI	22448-JA00C
SQ1F24	QR20DE	2000	07.06~	U13N04-COIL	4	EGI	22448-JA00C
SQ2F24	QR20DE	2000	07.06~	U13N04-COIL	4	EGI	22448-JA00C

アベニール

RNW11	QR20DE	2000	02.08~05.09	U08103-COIL	4	EGI	22448-8H315
RW11	QR20DE	2000	02.08~05.09	U08103-COIL	4	EGI	22448-8H315
W11	QG18DE	1800	98.08~00.07	U08001-COIL	4	EGI	22448-4M500
			00.07~05.09	U08101-COIL	4	EGI	22448-6N000

インフィニティ Q45

G50	VH45D	4500	89.10~95.02	U09121-COIL	2	コイル本体のみ/ソリッド #1,#2	22433-60U01
			95.02~97.09	●U09107-COIL	6	コイル Assy,#3-#8,EGI	22448-67U05
				●U09104-COIL	2	コイル本体のみ,#1,#2,EGI	22433-25U00
HG50	VH45D	4500	89.10~95.02	U09121-COIL	2	コイル本体のみ/ソリッド #1,#2	22433-60U01
			95.02~97.09	●U09107-COIL	6	コイル Assy,#3-#8,EGI	22448-67U05
				●U09104-COIL	2	コイル本体のみ,#1,#2,EGI	22433-25U00

ウイングロード

JY12	MR18DE	1800	05.11~14.09	U13N04-COIL	4	EGI	22448-ED000
NY12	HR15DE	1500	05.11~14.09	U13N04-COIL	4	EGI	22448-ED000
WFY11	QG15DE	1500	99.05~01.10	U08001-COIL	4	HITACHI CM11-205,EGI	22448-4M500
			01.10~05.12	U08101-COIL	4	HANSHIN AIC-4004G,EGI	22448-6N015
WHNY11	QG18DE	1800	99.05~00.10	U08001-COIL	4	HITACHI CM11-205,EGI	22448-4M500
			00.10~01.05	U08101-COIL	4	HANSHIN AIC-4004G,EGI	22448-6N000
			00.10~01.10	U08001-COIL	4	HITACHI CM11-205,EGI	22448-4M500
			01.05~05.12	U08101-COIL	4	HANSHIN AIC-4004G,EGI	22448-6N011
WHY11	QG18DE	1800	99.05~01.10	U08001-COIL	4	HITACHI CM11-205,EGI	22448-4M500
			00.10~01.10	U08101-COIL	4	HANSHIN AIC-4004G,EGI	22448-6N000
WRY11	QR20DE	2000	01.10~05.12	U08103-COIL	4	EGI	22448-8H310
Y12	HR15DE	1500	05.11~	U13N04-COIL	4	EGI	22448-ED000

エキスパート

VNW11	QG18DE	1800	99.06~00.11	U08001-COIL	4	EGI	22448-4M500
			00.11~06.12	U08101-COIL	4	EGI	22448-6N001

●印：生産終了品

トヨタ
TOYOTA日産
NISSANホンダ
HONDAマツダ
MAZDAスバル
SUBARU三菱
MITSUBISHIスズキ
SUZUKIダイハツ
DAIHATSUいすゞ
ISUZU対照表-1
純正品番順対照表-2
Astemo品番順

日産

NISSAN

車両型式	エンジン型式	排気量	年式	Astemo品番	使用数	類別内容	適応純正品番(参考)
------	--------	-----	----	----------	-----	------	------------

エキスパート

VW11	QG18DE	1800	99.06~00.11	U08001-COIL	4	EGI	22448-4M500
			00.11~06.12	U08101-COIL	4	EGI	22448-6N001

エルグランド

APE50	VQ35DE	3500	00.08~01.07	●U09117-COIL	1	Front,EGI	22448-4W001
				●U09120-COIL	5	Rear,EGI	22448-4W011
			01.07~01.10	U16N01-COIL	1	Front,EGI	22448-8J110
					5	Rear,EGI	22448-8J111
01.10~02.05	U16N01-COIL	6	オイル Assy,EGI	22448-8J115			
		6	オイル Assy,EGI	22448-8J115			
APWE50	VQ35DE	3500	00.08~01.07	●U09117-COIL	1	Front,EGI	22448-4W001
				●U09120-COIL	5	Rear,EGI	22448-4W011
			01.07~01.10	U16N01-COIL	1	Front,EGI	22448-8J110
					5	Rear,EGI	22448-8J111
01.10~02.05	U16N01-COIL	6	オイル Assy,EGI	22448-8J115			
		6	オイル Assy,EGI	22448-8J115			
E51	VQ35DE	3500	02.05~10.08	U16N01-COIL	6	EGI	22448-8J115
ME51	VQ25DE	2500	04.12~10.08	U16N01-COIL	6	EGI	22448-8J115
MNE51	VQ25DE	2500	04.12~10.08	U16N01-COIL	6	EGI	22448-8J115
NE51	VQ35DE	3500	02.05~10.08	U16N01-COIL	6	EGI	22448-8J115
PE52	VQ35DE	3500	10.08~	U16N02-COIL	6	EGI	22448-JA10C
PNE52	VQ35DE	3500	10.08~	U16N02-COIL	6	EGI	22448-JA10C
TE52	QR25DE	2500	10.08~	U13N04-COIL	4	EGI	22448-JA00C
TNE52	QR25DE	2500	10.08~	U13N04-COIL	4	EGI	22448-JA00C

オッティ

H91W	3G83	660	05.06~06.10	U11C01-COIL	3		22462-6A0AO
H92W	3G83	660	06.10~12.05	U11C01-COIL	3	EGI,TURBO	22462-6A0AO

キャラバン

CSGE25	QR25DE	2500	07.08~12.06	U13N04-COIL	4	EGI	22448-JA00C
DSGE25	QR25DE	2500	07.08~12.06	U13N04-COIL	4	EGI	22448-JA00C
SE25	QR25DE	2500	07.08~12.06	U13N04-COIL	4	EGI	22448-JA00C
SGE25	QR25DE	2500	07.08~12.06	U13N04-COIL	4	EGI	22448-JA00C
VRE25	QR20DE	2000	07.08~12.06	U13N04-COIL	4	EGI	22448-JA00C

キューブ

BNZ11	CR14DE	1400	02.10~08.11	U08108-COIL	4	EGI	22448-AX001
BZ11	CR14DE	1400	02.10~08.11	U08108-COIL	4	EGI	22448-AX001
NZ12	HR15DE	1500	08.11~14.11	U13N04-COIL	4	EGI	22448-JA00C
YZ11	HR15DE	1500	05.05~08.11	U13N04-COIL	4	EGI	22448-ED000
Z12	HR15DE	1500	08.11~	U13N04-COIL	4	EGI	22448-JA00C

キューブ キュービック

BGZ11	CR14DE	1400	03.09~08.11	U08108-COIL	4	EGI	22448-AX001
YGNZ11	HR15DE	1500	05.05~08.11	U13N04-COIL	4	EGI	22448-ED000
YGZ11	HR15DE	1500	05.05~08.11	U13N04-COIL	4	EGI	22448-ED000

キックス

H59A	4A30	660	08.10~	U15C01-COIL	1		22462-6A00A
				U15C02-COIL	1		22462-6A00B

西暦	1994	95	96	97	98	99	2000	01	02	03	04	05	06	07	08	09	10	11	12	13	14	15	16	17	18	19	20	21	22	23	24	25	26
和暦	平成6	7	8	9	10	11	12	13	14	15	16	17	18	19	20	21	22	23	24	25	26	27	28	29	30	令和元年	2	3	4	5	6	7	8

TOYOTA
トヨタ

NISSAN
日産

HONDA
ホンダ

MAZDA
マツダ

SUBARU
スバル

MITSUBISHI
三菱

SUZUKI
スズキ

DAIHATSU
ダイハツ

ISUZU
いすゞ

純正品番
対照表-1

Astemo品番
対照表-2

日産

NISSAN

車両型式	エンジン型式	排気量	年式	Astemo品番	使用数	類別内容	適応純正品番(参考)
------	--------	-----	----	----------	-----	------	------------

クリッパー

U71T	3G83	660	03.10~12.01	U11C01-COIL	3	EGI	22462-6A0A0
U71TP	3G83	660	03.10~12.01	U11C01-COIL	3	EGI	22462-6A0A0
U71TY	3G83	660	03.10~12.01	U11C01-COIL	3	EGI	22462-6A0A0
U71V	3G83	660	03.10~12.01	U11C01-COIL	3	EGI	22462-6A0A0
U72T	3G83	660	03.10~12.01	U11C01-COIL	3	EGI	22462-6A0A0
U72TP	3G83	660	03.10~12.01	U11C01-COIL	3	EGI	22462-6A0A0
U72TY	3G83	660	03.10~12.01	U11C01-COIL	3	EGI	22462-6A0A0
U72V	3G83	660	03.10~12.01	U11C01-COIL	3	EGI	22462-6A0A0

クリッパー リオ

U71W	3G83	660	03.10~12.01	U11C01-COIL	3	EGI,TURBO	22462-6A0A0
U72W	3G83	660	03.10~12.01	U11C01-COIL	3	EGI	22462-6A0A0

サニー

B15	QG13DE	1300	98.10~02.05	U08001-COIL	4	EGI	22448-4M500
			02.05~04.10	U08101-COIL	4	EGI	22448-6N015
FB15	QG15DE	1500	98.10~02.05	U08001-COIL	4	EGI	22448-4M500
			01.04~02.05	U08101-COIL	4	リボア/リボアツカ*スシヨ,EGI	22448-6N001
			02.05~04.10	U08101-COIL	4	EGI	22448-6N015
FNB15	QG15DE	1500	98.10~02.05	U08001-COIL	4	EGI	22448-4M500
			02.05~04.10	U08101-COIL	4	EGI	22448-6N015
QB15	QG18DD	1800	98.10~02.05	U08002-COIL	4	DI	22448-6J901

サファリ

WFGY61	TB48DE	4800	02.11~07.06	U08107-COIL	6	イル Assy,EGI	22448-AR210
--------	--------	------	-------------	-------------	---	-------------	-------------

シーマ

FGDY32	VH41DE	4100	91.08~95.05	U09121-COIL	2	イル本体のみ/リボア* #1,#2	22433-60U01
			95.05~97.04	●U09107-COIL	6	イル Assy,#3-#8,EGI	22448-67U05
				●U09104-COIL	2	イル本体のみ,#1,#2,EGI	22433-25U00
FGDY33	VH41DE	4100	96.06~01.01	U09103-COIL	8	EGI	22448-6P000
FGNY32	VH41DE	4100	92.08~95.05	U09121-COIL	2	イル本体のみ/リボア* #1,#2	22433-60U01
			95.05~97.09	●U09107-COIL	6	イル Assy,#3-#8,EGI	22448-67U05
				●U09104-COIL	2	イル本体のみ,#1,#2,EGI	22433-25U00
FGNY33	VH41DE	4100	97.09~01.01	U09103-COIL	8	EGI	22448-6P000
FGY32	VH41DE	4100	92.08~95.05	U09121-COIL	2	イル本体のみ/リボア* #1,#2	22433-60U01
			95.05~97.04	●U09107-COIL	6	イル Assy,#3-#8,EGI	22448-67U05
				●U09104-COIL	2	イル本体のみ,#1,#2,EGI	22433-25U00
FGY33	VH41DE	4100	96.06~01.01	U09103-COIL	8	EGI	22448-6P000
FHY33	VQ30DET	3000	96.06~01.01	U09106-COIL	6	TURBO	22448-31U16
FPY32	VG30DET	3000	93.09~96.06	●U09112-COIL	6	イル Assy,HANSHIN,TURBO	22448-F6513
				●U09111-COIL	6	イル本体のみ,HANSHIN,TURBO	22433-59S12
GF50	VK45DD	4500	01.01~03.08	U08106-COIL	8	DI	22448-AR000
			01.12~03.08	U08106-COIL	8	450XL,DI	22448-AR015
	VK45DE	4500	03.08~10.08	U08107-COIL	8	450XL,EGI	22448-AR215
GNF50	VK45DD	4500	01.01~03.11	U08106-COIL	8	450X FOUR,DI	22448-AR000
	VK45DE	4500	03.11~10.08	U08107-COIL	8	450X FOUR,EGI	22448-AR215
HF50	VQ30DET	3000	01.01~03.08	U09119-COIL	6	TURBO	22448-2Y006
HGY51	VQ35HR	3500	12.04~22.08	U16N02-COIL	6	EGI	22448-JA10C

シルビア

S15	SR20DET	2000	99.01~02.08	U09123-COIL	4	TURBO	22448-91F00
-----	---------	------	-------------	-------------	---	-------	-------------

●印：生産終了品

トヨタ
TOYOTA

日産
NISSAN

ホンダ
HONDA

マツダ
MAZDA

スバル
SUBARU

三菱
MITSUBISHI

スズキ
SUZUKI

ダイハツ
DAIHATSU

いすゞ
ISUZU

対照表-1
純正品番順

対照表-2
Astemo品番順

日産

NISSAN

車両型式	エンジン型式	排気量	年式	Astemo品番	使用数	類別内容	適応純正品番(参考)
------	--------	-----	----	----------	-----	------	------------

シルフィ

TB17	MRA8DE	1800	12.12~	U13N04-COIL	4	EGI	22448-JA00C
------	--------	------	--------	-------------	---	-----	-------------

ジューク

F15	MR16DDT	1600	10.11~	U17N01-COIL	4	TURBO,CVT	22448-1KCOA
NF15	MR16DDT	1600	10.11~	U17N01-COIL	4	TURBO,CVT	22448-1KCOA
YF15	HR15DE	1500	10.06~	U13N04-COIL	4	EGI	22448-1KTOA

スカイライン/スカイラインGT-R

BCNR33	RB26DETT	2600	95.01~99.01	U09122-COIL	6	オイル Assy,TURBO	22448-02U11
				U09121-COIL	6	オイル本体のみ	22433-60U02
BNR32	RB26DTT	2600	89.08~94.11	U09121-COIL	6	オイル本体のみ	22433-60U01
				U09122-COIL	6	オイル Assy	22448-02U10
BNR34	RB26DETT	2600	99.01~02.08	U09105-COIL	6	オイル Assy,TURBO	22448-25U00
				●U09104-COIL	6	オイル本体のみ,TURBO	22433-25U00
CPV35	VQ35DE	3500	03.01~07.07	U08105-COIL	6	オイル Assy,EGI	22448-AL615
CKV36	VQ37VHR	3700	07.10~14.03	U17N02-COIL	6	EGI	22448-EY00A
ECR32	RB25DE	2500	91.08~93.08	U09121-COIL	6	オイル本体のみ	22433-60U01
				U09122-COIL	6	オイル Assy	22448-02U10
ECR33	RB25DE	2500	93.08~95.01	U09121-COIL	6	オイル本体のみ,EGI	22433-60U01
				U09122-COIL	6	オイル Assy,EGI	22448-02U10
				U09105-COIL	6	オイル Assy,EGI	22448-25U00
	RB25DET	2500	93.08~95.01	●U09104-COIL	6	オイル本体のみ,EGI	22433-25U00
U09121-COIL				6	オイル本体のみ,TURBO	22433-60U01	
U09122-COIL				6	オイル Assy,TURBO	22448-02U10	
RB25DE	2500	95.01~98.05	U09105-COIL	6	オイル Assy,TURBO	22448-25U00	
			●U09104-COIL	6	オイル本体のみ,TURBO	22433-25U00	
ENR34	RB25DE	2500	98.05~01.06	U09108-COIL	6	オイル Assy,EGI	22448-AA101
ER32	RB25DE	2500	91.08~93.08	U09121-COIL	6	オイル本体のみ	22433-60U01
				U09122-COIL	6	オイル Assy	22448-02U10
ER33	RB25DE	2500	93.08~95.01	U09121-COIL	6	オイル本体のみ	22433-60U01
				U09122-COIL	6	オイル Assy	22448-02U10
	RB25DET	2500	95.01~98.05	U09105-COIL	6	オイル Assy,TURBO	22448-25U00
RB25DE	2500	98.05~01.06	●U09104-COIL	6	オイル本体のみ,TURBO	22433-25U00	
			U09108-COIL	6	オイル Assy,EGI	22448-AA101	
ER34	RB25DE	2500	98.05~01.06	U09108-COIL	6	オイル Assy,TURBO	22448-AA101
	RB25DET	2500	98.05~01.06	U09108-COIL	6	オイル Assy,TURBO	22448-AA101
HCR32	RB20DE	2000	89.05~93.08	U09121-COIL	6	オイル本体のみ	22433-60U01
				U09122-COIL	6	オイル Assy	22448-02U10
	RB20DT	2000	89.05~91.08	U09121-COIL	6	オイル本体のみ	22433-60U01
				U09122-COIL	6	オイル Assy	22448-02U10
	RB20DET	2000	91.08~93.08	U09121-COIL	6	オイル本体のみ	22433-60U01
				U09122-COIL	6	オイル Assy	22448-02U10
HNR32	RB20DT	2000	89.05~91.08	U09121-COIL	6	オイル本体のみ	22433-60U01
				U09122-COIL	6	オイル Assy	22448-02U10
	RB20DET	2000	91.08~93.08	U09121-COIL	6	オイル本体のみ	22433-60U01
RB20DE	2000	98.05~01.06	U09122-COIL	6	オイル Assy	22448-02U10	
			●U09109-COIL	6	オイル本体のみ,EGI	22433-AA000	
HNV37	VQ35HR	3500	13.11~	U16N02-COIL	6	EGI	22448-JA10C
HR32	RB20DE	2000	89.05~92.08	U09121-COIL	6	オイル本体のみ	22433-60U01
				U09122-COIL	6	オイル Assy	22448-02U10
HR34	RB20DE	2000	98.05~01.06	U09110-COIL	6	オイル Assy,EGI	22448-AA000
				●U09109-COIL	6	オイル本体のみ,EGI	22433-AA000
HV35	VQ30DD	3000	01.06~01.11	U08105-COIL	6	DI	22448-AL600
			01.11~04.11	U08105-COIL	6	オイル Assy,DI	22448-AL615
HV37	VQ35HR	3500	13.11~	U16N02-COIL	6	EGI	22448-JA10C

西暦	1994	95	96	97	98	99	2000	01	02	03	04	05	06	07	08	09	10	11	12	13	14	15	16	17	18	19	20	21	22	23	24	25	26
和暦	平成6	7	8	9	10	11	12	13	14	15	16	17	18	19	20	21	22	23	24	25	26	27	28	29	30	令和元年	2	3	4	5	6	7	8

TOYOTA トヨタ
NISSAN 日産
HONDA ホンダ
MAZDA マツダ
SUBARU スバル
MITSUBISHI ミツビシ
SUZUKI スズキ
DAIHATSU ダイハツ
ISUZU いすゞ
純正品番
対照表-1
Astemo品番
対照表-2

日産

NISSAN

車両型式	エンジン型式	排気量	年式	Astemo品番	使用数	類別内容	適応純正品番(参考)
------	--------	-----	----	----------	-----	------	------------

スカイライン/スカイラインGT-R

KV36	VQ37VHR	3700	08.12~	U17N02-COIL	6	EGI	22448-EY00A
NV35	VQ25DD	2500	01.07~06.11	U08104-COIL	6	イル Assy,DI	22448-AL510
NV36	VQ25HR	2500	06.11~14.03	U16N02-COIL	6	EGI	22448-JA10A
PV35	VQ35DE	3500	02.01~07.03	U08105-COIL	6	イル Assy,EGI	22448-AL615
PV36	VQ35HR	3500	06.11~08.12	U16N02-COIL	6	EGI	22448-JA10A
RV37	VR30/Hi	3000	19.07~	U24N02-COIL	6		22448-5CA0A
RV37	VR30/Lo	3000	19.07~	U24N02-COIL	6		22448-5CA0A
RV37	VR30DDTT	3000	19.07~	U24N02-COIL	6		22448-5CA0A
V35	VQ25DD	2500	01.06~06.11	U08104-COIL	6	イル Assy,DI	22448-AL510
V36	VQ25HR	2500	06.11~14.03	U16N02-COIL	6	EGI	22448-JA10A

スカイライン クロスオーバー

J50	VQ37VHR	3700	09.07~	U17N02-COIL	6	EGI	22448-EY00A
NJ50	VQ37VHR	3700	09.07~	U17N02-COIL	6	EGI	22448-EY00A

ステージア

HM35	VQ30DD	3000	01.10~04.08	U08105-COIL	6	DI	22448-AL610
M35	VQ25DD	2500	01.10~07.07	U08104-COIL	6	DI	22448-AL510
NM35	VQ25DD	2500	01.10~07.07	U08104-COIL	6	DI	22448-AL510
	VQ25DET	2500	01.10~04.08	U08105-COIL	6	TURBO	22448-AL61C
PM35	VQ35DE	3500	03.06~07.07	U08105-COIL	6	EGI,6MT,ｸﾞｽ350S	22448-AL615
			04.08~07.07	U08105-COIL	6	EGI,5AT	22448-AL615
PNM35	VQ35DE	3500	04.08~07.07	U08105-COIL	6	EGI	22448-AL615
WGC34	RB25DE	2500	96.09~97.08	●U09104-COIL	6	イル本体のみ	22433-25U00
				U09105-COIL	6	EGI	22448-25U00
			97.08~01.10	U09108-COIL	6	EGI	22448-5L300
WGNC34	RB25DE	2500	96.09~97.08	●U09104-COIL	6	イル本体のみ	22433-25U00
				U09105-COIL	6	EGI	22448-25U00
WGNC34	RB25DE	2500	97.08~01.10	U09108-COIL	6	EGI	22448-5L300
			96.09~98.08	●U09104-COIL	6	イル本体のみ	22433-25U00
				U09105-COIL	6	TURBO	22448-25U00
			98.08~01.03	U09108-COIL	6	TURBO	22448-AA101
			97.11~98.08	U09121-COIL	6	イル本体のみ/オーテック260RS仕様	22433-60U02
U09122-COIL	6	オーテック260RS仕様		22448-02U11			
WHC34	RB20DE	2000	97.08~98.08	U09108-COIL	6	EGI,20G	22448-5L300
			98.08~01.03	●U09109-COIL	6	イル本体のみ,EGI,20RS	22433-AA000
				U09110-COIL	6	EGI,20RS	22448-AA000

セドリック/グロリア

ENY33	RB25DET	2500	97.06~99.06	U09105-COIL	6	イル Assy,TURBO	22448-25U00
				●U09104-COIL	6	イル本体のみ,TURBO	22433-25U00
ENY34	RB25DET	2500	99.06~04.10	U09108-COIL	6	イル Assy,TURBO	22448-AA101
HBY33	VQ30DET	3000	95.06~99.05	U09106-COIL	6	TURBO	22448-31U16
HY33	VQ30DE	3000	95.06~99.05	U09106-COIL	6	EGI	22448-31U16
				U09106-COIL	6	TURBO	22448-31U16
HY34	VQ30DD	3000	99.06~01.12	U09113-COIL	6	DI	22448-2Y502
			01.12~04.10	U08105-COIL	6	イル Assy,DI	22448-AL615
			99.06~00.08	U09118-COIL	6	TURBO	22448-2Y005
00.08~01.12	U09119-COIL	6		TURBO	22448-2Y006		
MY33	VQ25DE	2500	97.06~99.05	U09106-COIL	6	EGI	22448-31U16

●印：生産終了品

トヨタ TOYOTA
日産 NISSAN
ホンダ HONDA
マツダ MAZDA
スバル SUBARU
三菱 MITSUBISHI
スズキ SUZUKI
ダイハツ DAIHATSU
いすゞ ISUZU
対照表-1 純正品番順
対照表-2 Astemo品番順

車両型式	エンジン型式	排気量	年式	Astemo品番	使用数	類別内容	適応純正品番(参考)
------	--------	-----	----	----------	-----	------	------------

セドリック/グロリア

MY34	VQ25DD	2500	99.06~01.12	U09114-COIL	6	DI	22448-2Y700
			01.12~04.10	U08104-COIL	6	オイル Assy,DI	22448-AL510
PAY32	VG30DT	3000	91.06~95.06	●U09111-COIL	6	オイル本体のみ/HANSHIN	22433-59S11
PBY32	VG30DT	3000	91.06~95.06	●U09111-COIL	6	オイル本体のみ/HANSHIN	22433-59S11
PY32	VG30DT	3000	91.06~95.06	●U09111-COIL	6	オイル本体のみ/HANSHIN	22433-59S11

セフィーロ

A31	RB20DT	2000	90.08~92.06	U09122-COIL	6	TURBO	22448-02U10
A32	VQ20DE	2000	94.08~98.12	U09101-COIL	3	RH,EGI	22448-31U00
				U09106-COIL	3	LH,EGI	22448-31U05
A33	VQ20DE	2000	98.12~02.08	U09115-COIL	3	RH,EGI	22448-2Y000
				U09118-COIL	3	LH,EGI	22448-2Y005
			02.08~03.03	●U09116-COIL	3	RH,EGI	22448-2Y001
				U09119-COIL	3	LH,EGI	22448-2Y006
CA31	RB20DE	2000	90.08~92.08	U09122-COIL	6	TURBO	22448-02U10
EA31	RB25DE	2500	92.06~94.08	U09122-COIL	6		22448-02U10
ECA31	RB25DE	2500	92.06~94.08	U09122-COIL	6		22448-02U10
HA32	VQ30DE	3000	94.08~98.12	U09101-COIL	3	RH,EGI	22448-31U00
				U09106-COIL	3	LH,EGI	22448-31U05
LA31	RB20DT	2000	90.08~94.08	U09122-COIL	6		22448-02U10
LCA31	RB20DT	2000	92.06~94.08	U09122-COIL	6		22448-02U10
LNA31	RB20DT	2000	90.08~94.08	U09122-COIL	6		22448-02U10
NA31	RB20DT	2000	90.08~92.06	U09122-COIL	6		22448-02U10
PA32	VQ25DE	2500	94.08~98.12	U09101-COIL	3	RH,EGI	22448-31U00
				U09106-COIL	3	LH,EGI	22448-31U05
PA33	VQ25DD	2500	98.12~02.08	U09114-COIL	6	DI	22448-2Y700
WA32	VQ20DE	2000	97.06~00.08	U09101-COIL	3	RH,EGI	22448-31U01
				U09106-COIL	3	LH,EGI	22448-31U06
WHA32	VQ30DE	3000	97.06~99.08	U09101-COIL	3	RH,EGI	22448-31U01
				U09106-COIL	3	LH,EGI	22448-31U06
WPA32	VQ25DE	2500	97.06~00.08	U09101-COIL	3	RH HANSHIN,EGI	22448-31U01
				U09106-COIL	3	LH HANSHIN,EGI	22448-31U06

セレナ

C25	MR20DE	2000	05.05~06.01	U15N01-COIL	4	EGI	22448-ED800
			06.01~10.11	U13N04-COIL	4	EGI	22448-ED000
C26	MR20DD	2000	10.11~16.08	U17N01-COIL	4	EGI,CVT	22448-1KCOA
C28	MR20DD	2000	22.12~	U24N01-COIL	4		22448-7DAOA
CC25	MR20DE	2000	06.01~10.11	U13N04-COIL	4	EGI	22448-ED000
CNC25	MR20DE	2000	06.01~10.11	U13N04-COIL	4	EGI	22448-ED000
FC26	MR20DD	2000	10.11~12.08	U17N01-COIL	4	EGI,CVT	22448-1KCOA
FC28	MR20DD	2000	22.12~	U24N01-COIL	4		22448-7DAOA
FNC26	MR20DD	2000	10.11~16.08	U17N01-COIL	4	EGI,CVT	22448-1KCOA
FNC28	MR20DD	2000	22.12~	U24N01-COIL	4		22448-7DAOA
GC27	MR20DD	2000	16.08~	U20N02-COIL	4	2WD	22448-5TAOA
GFC27	MR20DD	2000	16.08~	U20N02-COIL	4	2WD	22448-5TAOA
GFNC27	MR20DD	2000	16.08~	U20N02-COIL	4	4WD	22448-5TAOA
GNC27	MR20DD	2000	16.08~	U20N02-COIL	4	4WD	22448-5TAOA
HC26	MR20DD	2000	12.08~16.08	U17N01-COIL	4	EGI,CVT	22448-1KCOA
HFC26	MR20DD	2000	12.08~16.08	U17N01-COIL	4	EGI,CVT	22448-1KCOA
NC25	MR20DE	2000	05.05~06.01	U15N01-COIL	4	EGI	22448-ED800
			06.01~10.11	U13N04-COIL	4	EGI	22448-ED000
NC26	MR20DD	2000	10.11~16.08	U17N01-COIL	4	EGI,CVT	22448-1KCOA

西暦	1994	95	96	97	98	99	2000	01	02	03	04	05	06	07	08	09	10	11	12	13	14	15	16	17	18	19	20	21	22	23	24	25	26
和暦	平成6	7	8	9	10	11	12	13	14	15	16	17	18	19	20	21	22	23	24	25	26	27	28	29	30	令和元年	2	3	4	5	6	7	8

TOYOTA トヨタ
NISSAN 日産
HONDA ホンダ
MAZDA マツダ
SUBARU スバル
MITSUBISHI 三菱
SUZUKI スズキ
DAIHATSU ダイハツ
ISUZU いすゞ
純正品番
Astemo品番
対照表-1
対照表-2

日産

NISSAN

車両型式	エンジン型式	排気量	年式	Astemo品番	使用数	類別内容	適応純正品番 (参考)
------	--------	-----	----	----------	-----	------	----------------

セレナ

NC28	MR20DD	2000	22.12~	U24N01-COIL	4		22448-7DA0A
RC24	QR25DE	2500	01.12~05.05	U08103-COIL	4	EGI	22448-8H315
TC24	QR20DE	2000	01.12~05.05	U08103-COIL	4	EGI	22448-8H315
TNC24	QR20DE	2000	01.12~05.05	U08103-COIL	4	EGI	22448-8H315

ティアナ

J31	VQ23DE	2300	03.02~08.06	U16N01-COIL	6	オイル Assy,EGI	22448-8J115
J32	VQ25DE	2500	08.06~14.02	U16N02-COIL	6	EGI	22448-JA10C
L33	QR25DE	2500	14.01~	U13N04-COIL	4	EGI	22448-1KTOA
PJ31	VQ35DE	3500	03.02~08.06	U16N01-COIL	6	オイル Assy,EGI	22448-8J115
PJ32	VQ35DE	3500	08.06~14.02	U16N02-COIL	6	EGI	22448-JA10C
TNJ31	QR25DE	2500	03.02~08.06	U08103-COIL	4	オイル Assy,EGI	22448-8H315
TNJ32	QR25DE	2500	08.06~14.02	U13N04-COIL	4	EGI	22448-JA00C

ティーダ

C11	HR15DE	1500	04.09~12.08	U13N04-COIL	4	EGI	22448-ED000
JC11	MR18DE	1800	05.01~05.12	U15N01-COIL	4	EGI	22448-ED800
			05.12~10.08	U13N04-COIL	4	EGI	22448-ED000
NC11	HR15DE	1500	04.09~12.08	U13N04-COIL	4	EGI	22448-ED000

ティーダ ラティオ

SC11	HR15DE	1500	04.10~12.10	U13N04-COIL	4	EGI	22448-ED000
SJC11	MR18DE	1800	05.01~05.12	U15N01-COIL	4	EGI	22448-ED800
			05.12~10.08	U13N04-COIL	4	EGI	22448-ED000
SNC11	HR15DE	1500	04.10~12.10	U13N04-COIL	4	EGI	22448-ED000
SZC11	HR16DE	1600	08.09~12.10	U13N04-COIL	4	EGI,教習車	22448-ED000

ティーン

V10	QG18DE	1800	98.12~02.10	U08001-COIL	4	EGI	22448-4M500
			02.10~03.03	U08101-COIL	4	EGI	22448-6N015

デイズ

4AA-B45W	BR06T	660	19.03~	U20N01-COIL	3	2WD,TURBO	22448-1KTOB
4AA-B48W	BR06T	660	19.03~	U20N01-COIL	3	4WD,TURBO	22448-1KTOB
5AA-B44W	BRO6	660	19.03~	U20N01-COIL	3	2WD	22448-1KTOB
5BA-B43W	BRO6	660	19.03~	U20N01-COIL	3	2WD	22448-1KTOB
5BA-B46W	BRO6	660	19.03~	U20N01-COIL	3	4WD	22448-1KTOB
5AA-B47W	BRO6	660	19.03~	U20N01-COIL	3	4WD	22448-1KTOB
B21W	3B20	660	13.06~16.11	U19N02-COIL	3		22462-6A00D

デイズルークス

B21A	3B20	660	14.02~	U19N02-COIL	3		22462-6A00D
------	------	-----	--------	-------------	---	--	-------------

デュアリス

J10	MR20DE	2000	07.05~07.12	U13N04-COIL	4	EGI	22448-JA00C
KJ10	MR20DE	2000	07.12~14.03	U13N04-COIL	4	EGI	22448-JA00C
KNJ10	MR20DE	2000	07.12~14.03	U13N04-COIL	4	EGI	22448-JA00C
NJ10	MR20DE	2000	07.05~07.12	U13N04-COIL	4	EGI	22448-JA00C

●印：生産終了品

日産

NISSAN

車両型式	エンジン型式	排気量	年式	Astemo品番	使用数	類別内容	適応純正品番(参考)
------	--------	-----	----	----------	-----	------	------------

ノート

E11	HR15DE	1500	05.01~12.09	U13N04-COIL	4	EGI	22448-ED000
E12	HR12DDR	1200	12.09~	U13N03-COIL	3	DI	22448-3HDOA
	HR12DE	1200	12.09~	U13N04-COIL	3	EGI	22448-1KTOA
14.10~			U13N04-COIL	4	EGI,NISMO	22448-1KTOA	
NE11	HR15DE	1500	05.01~12.09	U13N04-COIL	4	EGI	22448-ED000
NE12	HR12DE	1200	12.09~	U13N04-COIL	3	EGI	22448-1KTOA
ZE11	HR16DE	1600	08.10~12.09	U13N04-COIL	4	EGI	22448-JA00C

バサラ

JHU30	VQ30DE	3000	99.11~03.06	U09101-COIL	3	RH,EGI	22448-AD101
				(●U09102-COIL)			
				U09106-COIL	3	LH,EGI	22448-31U06
JTNU30	QR25DE	2500	01.08~03.06	U08103-COIL	4	オイル Assy,EGI	22448-8H310
JTU30	QR25DE	2500	01.08~03.06	U08103-COIL	4	オイル Assy,EGI	22448-8H310

バネット

SKP2VN	GAS18	1800	10.08~	U22M01-COIL	4		22433-HA001
--------	-------	------	--------	-------------	---	--	-------------

バネットバン/トラック

S21	GAS18	1800	10.08~	U22M01-COIL	4		22433-HA001
-----	-------	------	--------	-------------	---	--	-------------

ピノ

HC24S	K6A	660	07.01~09.11	U21S02-COIL	3	EPI	22448-4A00B
-------	-----	-----	-------------	-------------	---	-----	-------------

フーガ

GY50	VK45DE	4500	05.08~09.11	U08107-COIL	8	EGI	22448-AR215
HY51	VQ35HR	3500	10.11~19.12	U16N02-COIL	6	EGI	22448-JA10C
KNY51	VQ37VHR	3700	09.11~	U17N02-COIL	6	EGI	22448-EY00A
KY51	VQ37VHR	3700	09.11~	U17N02-COIL	6	EGI	22448-EY00A
PNY50	VQ35DE	3500	04.10~07.12	U08105-COIL	6	EGI	22448-AL615
	VQ35HR	3500	07.12~09.11	U16N02-COIL	6	EGI	22448-JA10C
PY50	VQ35DE	3500	04.10~07.12	U08105-COIL	6	EGI	22448-AL615
	VQ35HR	3500	07.12~09.11	U16N02-COIL	6	EGI	22448-JA10C
Y50	VQ25DE	2500	04.10~07.12	U08105-COIL	6	EGI	22448-AL615
	VQ25HR	2500	07.12~09.11	U16N02-COIL	6	EGI	22448-JA10C
Y51	VQ25HR	2500	09.11~	U16N02-COIL	6	EGI	22448-JA10C

フェアレディZ

HZ33	VQ35DE	3500	03.10~07.01	U08105-COIL	6	オイル Assy,EGI	22448-AL615
	VQ35HR	3500	07.01~08.12	U16N02-COIL	6	EGI	22448-JA10A
HZ34	VQ37VHR	3700	09.10~15.07	U17N02-COIL	6	EGI	22448-EY00A
Z33	VQ35DE	3500	02.07~07.01	U08105-COIL	6	オイル Assy,EGI	22448-AL615
	VQ35HR	3500	07.01~08.12	U16N02-COIL	6	EGI	22448-JA10A
Z34	VQ37VHR	3700	08.12~	U17N02-COIL	6	EGI	22448-EY00A
	VR30DDTT	3000	22.08~	U24N02-COIL	6		22448-5CA0A

ブルーバード

QU14	QG18DD	1800	98.09~01.08	U08002-COIL	4	DI	22448-6J901
	QG18DE	1800	98.09~01.08	U08001-COIL	4	EGI	22448-4M500

西暦	1994	95	96	97	98	99	2000	01	02	03	04	05	06	07	08	09	10	11	12	13	14	15	16	17	18	19	20	21	22	23	24	25	26
和暦	平成6	7	8	9	10	11	12	13	14	15	16	17	18	19	20	21	22	23	24	25	26	27	28	29	30	令和元年	2	3	4	5	6	7	8

TOYOTA
トヨタ

NISSAN
日産

HONDA
ホンダ

MAZDA
マツダ

SUBARU
スバル

MITSUBISHI
三菱

SUZUKI
スズキ

DAIHATSU
ダイハツ

ISUZU
いすゞ

純正品番
対照表-1

Astemo品番
対照表-2

日産

NISSAN

車両型式	エンジン型式	排気量	年式	Astemo品番	使用数	類別内容	適応純正品番(参考)
------	--------	-----	----	----------	-----	------	------------

ブルーバードシルフィ

FG10	QG15DE	1500	00.08~05.12	U08101-COIL	4	EGI	22448-6N000
G11	HR15DE	1500	05.12~12.12	U13N04-COIL	4	EGI	22448-ED000
KG11	MR20DE	2000	05.12~12.12	U13N04-COIL	4	EGI	22448-ED000
NG11	HR15DE	1500	05.12~12.12	U13N04-COIL	4	EGI	22448-ED000
QG10	QG18DE	1800	00.08~05.12	U08101-COIL	4	EGI	22448-6N000
QNG10	QG18DE	1800	00.08~05.12	U08101-COIL	4	EGI	22448-6N000
TG10	QR20DD	2000	00.08~05.12	U08102-COIL	4	DI	22448-6N200

プリメーラ

HP12	SR20VE	2000	01.08~03.07	U09123-COIL	4	EGI	22448-91F00
QP11	QG18DD	1800	98.09~01.01	U08002-COIL	4	DI	22448-6J901
	QG18DE	1800	98.09~01.01	U08001-COIL	4	EGI	22448-4M500
QP12	QG18DE	1800	02.02~05.12	U08101-COIL	4	EGI	22448-6N015
RP12	QR25DD	2500	01.01~05.12	U08102-COIL	4	DI	22448-6N200
TNP12	QR20DE	2000	01.05~05.12	U08103-COIL	4	EGI	22448-8H310
TP12	QR20DE	2000	01.01~05.12	U08103-COIL	4	EGI	22448-8H300
WHP12	SR20VE	2000	01.08~03.07	U09123-COIL	4	EGI	22448-91F00
WQP11	QG18DD	1800	98.09~01.01	U08002-COIL	4	DI	22448-6J901
	QG18DE	1800	98.09~01.01	U08001-COIL	4	EGI	22448-4M500
WRP12	QR25DD	2500	01.01~05.12	U08102-COIL	4	DI	22448-6N200
WTNP12	QR20DE	2000	01.01~05.12	U08103-COIL	4	EGI	22448-8H300
WTP12	QR20DE	2000	01.01~05.12	U08103-COIL	4	EGI	22448-8H300

プレーリー リバティ

RM12	QR20DE	2000	01.05~04.12	U08103-COIL	4	EGI	22448-8H310
RNM12	QR20DE	2000	01.05~04.12	U08103-COIL	4	EGI	22448-8H310

プレサージュ

HU30	VQ30DE	3000	98.06~03.07	U09101-COIL	3	RH,EGI	22448-AD101
				(●U09102-COIL)			
				U09106-COIL	3	LH,EGI	22448-31U06
PNU31	VQ35DE	3500	03.06~06.05	U16N01-COIL	6	EGI	22448-8J115
PU31	VQ35DE	3500	03.06~09.09	U16N01-COIL	6	EGI	22448-8J115
TNU30	QR25DE	2500	01.08~03.07	U08103-COIL	4	オイル Assy,EGI	22448-8H310
TNU31	QR25DE	2500	03.06~06.06	U08103-COIL	4	EGI	22448-8H315
TU30	QR25DE	2500	01.08~03.07	U08103-COIL	4	オイル Assy,EGI	22448-8H310
TU31	QR25DE	2500	03.06~06.06	U08103-COIL	4	EGI	22448-8H315

プレジデント

JG50	VH45DE	4500	95.02~02.08	●U09107-COIL	6	#3-#8,EGI	22448-67U05
				●U09104-COIL	2	オイル本体のみ/リリグ #1,#2	22433-25U00
JHG50	VH45DE	4500	95.02~02.08	●U09107-COIL	6	#3-#8,EGI	22448-67U05
PG50	VH45DE	4500	95.02~02.08	●U09107-COIL	6	#3-#8,EGI	22448-67U05
				●U09104-COIL	2	オイル本体のみ/リリグ #1,#2	22433-25U00
PGF50	VK45DE	4500	03.10~10.08	U08107-COIL	8	オイル Assy,EGI	22448-AR215
PHG50	VH45DE	4500	95.02~02.08	●U09107-COIL	6	#3-#8,EGI	22448-67U05
				●U09104-COIL	2	オイル本体のみ/リリグ #1,#2	22433-25U00

マーチ

AK12	CR12DE	1200	02.02~10.07	U08108-COIL	4	EGI	22448-AX001
BK12	CR14DE	1400	02.02~05.08	U08108-COIL	4	EGI	22448-AX001
BNK12	CR14DE	1400	02.02~10.07	U08108-COIL	4	EGI	22448-AX001

●印：生産終了品

トヨタ
TOYOTA日産
NISSANホンダ
HONDAマツダ
MAZDAスバル
SUBARU三菱
MITSUBISHIスズキ
SUZUKIダイハツ
DAIHATSUいすゞ
ISUZU対照表-1
純正品番順対照表-2
Astemo品番順

日産

NISSAN

車両型式	エンジン型式	排気量	年式	Astemo品番	使用数	類別内容	適応純正品番(参考)
------	--------	-----	----	----------	-----	------	------------

マーチ

K12	CR10DE	1000	02.02~03.07	U08108-COIL	4	EGI	22448-AX001
K13	HR12DE	1200	10.07~	U13N04-COIL	3	EGI	22448-JA00C
NK13	HR12DE	1200	10.07~20.07	U13N04-COIL	3	EGI	22448-JA00C
YK12	HR15DE	1500	05.08~10.07	U13N04-COIL	4	EGI	22448-ED000

マイクラ

FHZK12	HR16DE	1600	07.04~10.08	U15N01-COIL	4	EGI	22448-ED800
--------	--------	------	-------------	-------------	---	-----	-------------

ムラーノ

PNZ50	VQ35DE	3500	04.09~08.09	U16N01-COIL	6	EGI	22448-8J115
PNZ51	VQ35DE	3500	08.09~15.03	U16N02-COIL	6	EGI	22448-JA10C
PZ50	VQ35DE	3500	04.09~08.09	U16N01-COIL	6	EGI	22448-8J115
TNZ51	QR25DE	2500	08.09~15.03	U13N04-COIL	4	EGI	22448-JA00C
TZ50	QR25DE	2500	04.09~08.09	U08103-COIL	4	EGI	22448-8H314
TZ51	QR25DE	2500	10.01~15.03	U13N04-COIL	4	EGI	22448-JA00C

モコ

MG21S	K6A	660	02.04~06.02	U21S02-COIL	3	EPI,TURBO	22448-4A0A0
MG22S	K6A	660	06.02~11.02	U21S02-COIL (●U12S01-COIL)	3	EPI,TURBO	22448-4A0A2
MG33S	R06A	660	11.02~	U19S01-COIL	3		22448-4A01A

ラティオ

N17	HR12DE	1200	12.10~	U13N04-COIL	3	EGI	22448-JA00C
-----	--------	------	--------	-------------	---	-----	-------------

ラフェスタ

B30	MR20DE	2000	04.12~13.03	U13N04-COIL	4	EGI	22448-EN200
B35	LF.VD	2000	11.06~	U18M01-COIL	4		22448-HA00A
	LF.VDS	2000	11.06~	U18M01-COIL	4		22448-HA00A
	LF.VE	2000	11.06~	U18M01-COIL	4		22448-HA00A
NB30	MR20DE	2000	04.12~13.03	U13N04-COIL	4	EGI	22448-EN200

ルークス

4AA-B45A	BR06T	660	20.03~	U20N01-COIL	3	2WD,TURBO	22448-1KT0B
4AA-B48A	BR06T	660	20.03~	U20N01-COIL	3	4WD,TURBO	22448-1KT0B
5AA-B44A	BR06	660	20.03~	U20N01-COIL	3	2WD	22448-1KT0B
5AA-B47A	BR06	660	20.03~	U20N01-COIL	3	4WD	22448-1KT0B
ML21S	K6A	660	09.12~13.03	U21S02-COIL	3	EPI,TURBO	22448-4A00B

レパード

JENY33	RB25DET	2500	97.10~99.06	U09105-COIL	6	オイル Assy,TURBO	22448-25U00
				●U09104-COIL	6	オイル本体のみ,TURBO	22433-25U00
JHBY33	VQ30DET	3000	96.03~99.06	U09106-COIL	6	TURBO	22448-31U16
JHY33	VQ30DE	3000	96.03~97.10	U09106-COIL	6	EGI	22448-31U16
	VQ30DET	3000	96.03~99.06	U09106-COIL	6	TURBO	22448-31U16
JMY33	VQ25DE	2500	97.10~99.06	U09106-COIL	6	EGI	22448-31U16

ローレル

EC33	RB25D	2500	91.10~93.01	U09121-COIL	6	オイル本体のみ	22433-60U01
ECC33	RB25D	2500	91.10~93.01	U09121-COIL	6	オイル本体のみ	22433-60U01

西暦	1994	95	96	97	98	99	2000	01	02	03	04	05	06	07	08	09	10	11	12	13	14	15	16	17	18	19	20	21	22	23	24	25	26
和暦	平成6	7	8	9	10	11	12	13	14	15	16	17	18	19	20	21	22	23	24	25	26	27	28	29	30	令和元年	2	3	4	5	6	7	8

TOYOTA
トヨタ

NISSAN
日産

HONDA
ホンダ

MAZDA
マツダ

SUBARU
スバル

MITSUBISHI
三菱

SUZUKI
スズキ

DAIHATSU
ダイハツ

ISUZU
いすゞ

純正品番
対照表-1

Astemo品番
対照表-2

日産

NISSAN

車両型式	エンジン型式	排気量	年式	Astemo品番	使用数	類別内容	適応純正品番 (参考)
------	--------	-----	----	----------	-----	------	----------------

ローレル

GC34	RB25DE	2500	93.01~94.09	U09121-COIL	6	オイル本体のみ	22433-60U02
				U09122-COIL	6		22448-02U11
			94.09~97.06	●U09104-COIL	6	オイル本体のみ	22433-25U00
	RB25DET	2500	94.01~94.09	U09121-COIL	6	オイル本体のみ	22433-60U02
				U09122-COIL	6		22448-02U11
			94.09~97.06	●U09104-COIL	6	オイル本体のみ	22433-25U00
GC35	RB25DE	2500	97.06~02.08	U09108-COIL	6	オイル Assy,EGI	22448-5L300
	RB25DET	2500	97.06~02.08	U09108-COIL	6	オイル Assy,TURBO	22448-5L300
GCC34	RB25DE	2500	93.01~94.01	U09121-COIL	6	オイル本体のみ	22433-60U02
				U09122-COIL	6		22448-02U11
	RB25DET	2500	94.01~94.09	U09121-COIL	6	オイル本体のみ	22433-60U02
				U09122-COIL	6		22448-02U11
GCC35	RB25DET	2500	97.06~02.08	U09108-COIL	6	オイル Assy,TURBO	22448-5L300
				●U09104-COIL	6	オイル本体のみ	22433-25U00
GNC34	RB25DE	2500	94.09~97.06	U09105-COIL	6		22448-25U00
				U09108-COIL	6	オイル Assy,EGI	22448-5L300
GNC35	RB25DE	2500	97.06~02.08	U09108-COIL	6	オイル Assy,EGI	22448-5L300
				●U09111-COIL	6	オイル本体のみ	22433-59S11
HC33	RB20DE	2000	88.12~91.01	U09121-COIL	6	オイル本体のみ	22433-60U01
	RB20DT	2000	91.01~93.01	U09121-COIL	6	オイル本体のみ	22433-60U01
HC34	RB20DE	2000	93.01~94.09	U09121-COIL	6	オイル本体のみ	22433-60U02
				U09122-COIL	6		22448-02U11
				●U09109-COIL	6	オイル本体のみ,EGI	22433-AA000
HC35	RB20DE	2000	97.06~99.01	U09108-COIL	6	オイル Assy,EGI	22448-5L300
			99.01~02.08	U09110-COIL	6	オイル Assy,EGI	22448-AA000
HCC33	RB20DE	2000	88.12~91.01	●U09111-COIL	6	オイル本体のみ	22433-59S11
	RB20DT	2000	91.01~93.01	U09121-COIL	6	オイル本体のみ	22433-60U01

トヨタ
TOYOTA

日産
NISSAN

ホンダ
HONDA

マツダ
MAZDA

スバル
SUBARU

三菱
MITSUBISHI

スズキ
SUZUKI

ダイハツ
DAIHATSU

いすゞ
ISUZU

対照表-1
純正品番順

対照表-2
Astemo品番順

●印：生産終了品

ホンダ

HONDA

車両型式	エンジン型式	排気量	年式	Astemo品番	使用数	類別内容	適応純正品番(参考)
------	--------	-----	----	----------	-----	------	------------

CR-V

RD1	B20B	2000	95.10~01.08	U12H01-COIL (●U12H06-COIL)	1		30510-PT2-006
RD2	B20B	2000	98.12~01.08	U12H01-COIL (●U12H06-COIL)	1		30510-PT2-006
RD4	K20A	2000	01.08~04.09	U14H01-COIL	4		30520-PNA-007
RD5	K20A	2000	01.08~04.09	U14H01-COIL	4		30520-PNA-007
RD6	K24A	2400	04.09~06.10	U14H01-COIL	4		30520-PNA-007
RD7	K24A	2400	04.09~06.10	U14H01-COIL	4		30520-PNA-007
RE3	K24A	2400	06.10~11.10	U14H01-COIL	4		30520-PNA-007
RE4	K24A	2400	06.10~11.10	U14H01-COIL	4		30520-PNA-007
			11.11~16.08	U17H01-COIL	4	4WD	30520-R40-007

CR-X デルソル

EG1	D15B	1500	92.02~95.09	U12H01-COIL (●U12H06-COIL)	1		30510-PT2-006
EG2	B16A	1600	92.02~97.07	U12H01-COIL (●U12H06-COIL)	1		30510-PT2-006
EJ4	D16A	1600	95.09~97.07	U12H01-COIL (●U12H06-COIL)	1		30510-PT2-006

CR-Z

ZF1	LEA	1500	10.02~12.09	U09005-COIL	4		30520-RB0-003
ZF2	LEA	1500	12.09~	U09005-COIL	4		30520-RB0-S01

HR-V

GH1	D16A	1600	98.09~03.10	U12H01-COIL (●U12H06-COIL)	1		30510-PT2-006
GH2	D16A	1600	98.09~03.10	U12H01-COIL (●U12H06-COIL)	1		30510-PT2-006
GH3	D16A	1600	99.07~05.09	U12H01-COIL (●U12H06-COIL)	1		30510-PT2-006
GH4	D16A	1600	99.07~05.09	U12H01-COIL (●U12H06-COIL)	1		30510-PT2-006

MDX

YD1	J35A	3500	03.03~06.06	U09001-COIL	6		30520-PGK-A01
-----	------	------	-------------	-------------	---	--	---------------

NSX

NC1-100	JNC	3500	17.02~17.12	U20H01-COIL	6	4WD	30520-58G-003
NC1-110	JNC	3500	18.01~19.04	U20H01-COIL	6	4WD	30520-58G-003
NC1-120	JNC	3500	19.05~20.03	U20H01-COIL	6	4WD	30520-58G-003
NC1-130	JNC	3500	20.04~	U20H01-COIL	6	4WD	30520-58G-003

N-BOX

JF1	S07A	660	11.12~13.11	U22H01-COIL	3	FF 7L-1No.100~140,200~220, 510~520,610~620	30520-R9G-004
			13.12~17.08	U16H05-COIL	3		30520-5Z1-003
JF2	S07A	660	11.12~13.11	U16H06-COIL	3	TURBO	30520-5Z2-003
				U22H01-COIL	3	4WD 7L-1No.100-120,200-220	30520-R9G-004
			13.12~17.08	U16H05-COIL	3		30520-5Z1-003
				U16H06-COIL	3	TURBO	30520-5Z2-003

西暦	1994	95	96	97	98	99	2000	01	02	03	04	05	06	07	08	09	10	11	12	13	14	15	16	17	18	19	20	21	22	23	24	25	26
和暦	平成6	7	8	9	10	11	12	13	14	15	16	17	18	19	20	21	22	23	24	25	26	27	28	29	30	令和元年	2	3	4	5	6	7	8

TOYOTA
トヨタ

NISSAN
日産

HONDA
ホンダ

MAZDA
マツダ

SUBARU
スバル

MITSUBISHI
三菱

SUZUKI
スズキ

DAIHATSU
ダイハツ

ISUZU
いすゞ

純正品番
対照表-1

Astemo品番
対照表-2

ホンダ

HONDA

車両型式	エンジン型式	排気量	年式	Astemo品番	使用数	類別内容	適応純正品番(参考)
------	--------	-----	----	----------	-----	------	------------

N-BOX

JF3-100,200	S07B	660	17.09~19.09	U20H01-COIL	3	2WD	30520-58G-003
JF3-140,220	S07B	660	19.10~	U20H01-COIL	3	2WD	30520-58G-003
JF4-100,200	S07B	660	17.09~19.09	U20H01-COIL	3	4WD	30520-58G-003
JF4-110,210	S07B	660	19.10~20.11	U20H01-COIL	3	4WD	30520-58G-003

N-BOX カスタム

JF1	S07A	660	11.12~13.11	U22H01-COIL	3	FF	30520-R9G-004
JF2	S07A	660	11.12~13.11	U22H01-COIL	3	4WD	30520-R9G-004
JF3-100,200	S07B	660	17.09~19.09	U20H01-COIL	3	2WD	30520-58G-003
JF3-140,220	S07B	660	19.10~	U20H01-COIL	3	2WD	30520-58G-003
JF4-100,200	S07B	660	17.09~19.09	U20H01-COIL	3	4WD	30520-58G-003
JF4-110,210	S07B	660	19.10~20.11	U20H01-COIL	3	4WD	30520-58G-003

N-BOX カスタムSL

JF3-300,400,800	S07B	660	18.04~	U20H01-COIL	3	2WD	30520-58G-003
JF3-820	S07B	660	19.10~20.11	U20H01-COIL	3	2WD	30520-58G-003
JF4-300,400,800	S07B	660	18.04~	U20H01-COIL	3	4WD	30520-58G-003
JF4-820	S07B	660	19.10~20.11	U20H01-COIL	3	4WD	30520-58G-003

N-BOX スラッシュ

JF1	S07A	660	14.12~	U16H05-COIL	3		30520-5Z1-003
				U16H06-COIL	3	TURBO	30520-5Z2-003
JF2	S07A	660	14.12~	U16H05-COIL	3		30520-5Z1-003
				U16H06-COIL	3	TURBO	30520-5Z2-003

N-BOX スロープ

JF3-300,400,800,810	S07B	660	18.04~	U20H01-COIL	3	2WD	30520-58G-003
JF3-820	S07B	660	19.10~20.11	U20H01-COIL	3	2WD	30520-58G-003
JF4-300,400,800,810	S07B	660	18.04~	U20H01-COIL	3	4WD	30520-58G-003
JF4-820	S07B	660	19.10~20.11	U20H01-COIL	3	4WD	30520-58G-003

N-BOX+(プラス)

JF1	S07A	660	12.07~13.12	U22H01-COIL	3	FF 7L-1No.300-320,400-420,800-840	30520-R9G-004
			13.12~	U16H05-COIL	3		30520-5Z1-003
				U16H06-COIL	3	TURBO	30520-5Z2-003
JF2	S07A	660	12.07~13.12	U22H01-COIL	3	4WD 7L-1No.300-320,400-420,800-840	30520-R9G-004
			13.12~	U16H05-COIL	3		30520-5Z1-003
				U16H06-COIL	3	TURBO	30520-5Z2-003

N-ONE

JG1	S07A	660	12.11~15.06	U16H05-COIL	3		30520-5Z1-003
			12.11~15.06	U16H06-COIL	3	TURBO	30520-5Z2-003
				U22H01-COIL	3		30520-R9G-004
JG2	S07A	660	12.11~15.06	U16H05-COIL	3		30520-5Z1-003
			12.11~	U16H06-COIL	3	TURBO	30520-5Z2-003

●印：生産終了品

トヨタ TOYOTA
日産 NISSAN
ホンダ HONDA
マツダ MAZDA
スバル SUBARU
三菱 MITSUBISHI
スズキ SUZUKI
ダイハツ DAIHATSU
いすゞ ISUZU
対照表-1 純正品番順
対照表-2 Astemo品番順

ホンダ

HONDA

車両型式	エンジン型式	排気量	年式	Astemo品番	使用数	類別内容	適応純正品番(参考)
------	--------	-----	----	----------	-----	------	------------

N-VAN

JJ1-100,200,300,400	S07B	660	18.07~	U20H01-COIL	3	2WD	30520-58G-003
JJ2-100,200,300,400	S07B	660	18.07~	U20H01-COIL	3	4WD	30520-58G-003

N-WGN

JH1	S07A	660	13.11~	U16H05-COIL	3		30520-5Z1-003
				U16H06-COIL	3	TURBO	30520-5Z2-003
JH2	S07A	660	13.11~	U16H05-COIL	3		30520-5Z1-003
				U16H06-COIL	3	TURBO	30520-5Z2-003
JH3	S07B	660	19.07~	U20H01-COIL	3	2WD	30520-58G-003
JH4	S07B	660	19.07~	U20H01-COIL	3	4WD	30520-58G-003

N-WGN カスタム

JH3	S07B	660	19.07~	U20H01-COIL	3	2WD	30520-58G-003
JH4	S07B	660	19.07~	U20H01-COIL	3	4WD	30520-58G-003

S660

JW5	S07A	660	15.04~	U16H06-COIL	3	TURBO	30520-5Z2-003
-----	------	-----	--------	-------------	---	-------	---------------

S2000

AP1	F20C	2000	98.04~05.11	U14H01-COIL	4		30520-PCX-007
-----	------	------	-------------	-------------	---	--	---------------

S-MX

RH1	B20B	2000	96.11~02.01	U12H01-COIL (●U12H06-COIL)	1		30510-PT2-006
RH2	B20B	2000	96.11~02.01	U12H01-COIL (●U12H06-COIL)	1		30510-PT2-006

Z

PA1	E07Z	660	98.10~02.01	U09001-COIL	3		30520-PFB-007
-----	------	-----	-------------	-------------	---	--	---------------

アヴァンシア

TA3	J30A	3000	99.09~03.06	U09001-COIL	6		30520-P8E-A01
TA4	J30A	3000	00.02~03.06	U09001-COIL	6		30520-P8E-A01

アクティ

HA3	E07A	660	90.02~99.07	U12H09-COIL	1		30500-PE0-006
HA4	E07A	660	90.02~99.07	U12H09-COIL	1		30500-PE0-006
HA5	E07A	660	95.12~99.05	U12H09-COIL	1		30500-PE0-006
HA6	E07Z	660	99.05~03.05	U09001-COIL	3	ダノンジエフ,DENSO	30520-PFE-004
			99.05~10.01	U09001-COIL	3	トラック	30520-PXH-004
HA7	E07Z	660	99.05~03.05	U09001-COIL	3	ダノンジエフ,DENSO	30520-PFE-004
			99.05~09.12	U09001-COIL	3	トラック	30520-PXH-004
HA8	E07Z	660	09.12~	U15H01-COIL	3	Assy	30520-RS8-004
HA9	E07Z	660	09.12~	U15H01-COIL	3	Assy	30520-RS8-004
HH3	E07A	660	90.02~99.06	U12H09-COIL	1		30500-PE0-006
HH4	E07A	660	90.02~99.06	U12H09-COIL	1		30500-PE0-006
HH5	E07Z	660	99.06~10.08	U09001-COIL	3		30520-PXH-004
			10.08~	U15H01-COIL	3		30520-RS8-004

西暦	1994	95	96	97	98	99	2000	01	02	03	04	05	06	07	08	09	10	11	12	13	14	15	16	17	18	19	20	21	22	23	24	25	26
和暦	平成6	7	8	9	10	11	12	13	14	15	16	17	18	19	20	21	22	23	24	25	26	27	28	29	30	令和元年	2	3	4	5	6	7	8

TOYOTA
トヨタ

NISSAN
日産

HONDA
ホンダ

MAZDA
マツダ

SUBARU
スバル

MITSUBISHI
三菱

SUZUKI
スズキ

DAIHATSU
ダイハツ

ISUZU
いすゞ

純正品番
対照表-1

Astemo品番
対照表-2

ホンダ

HONDA

車両型式	エンジン型式	排気量	年式	Astemo品番	使用数	類別内容	適応純正品番 (参考)
------	--------	-----	----	----------	-----	------	----------------

アクティ

HH6	E07Z	660	99.06~	U09001-COIL	3		30520-PXH-004
			99.06~	U15H01-COIL	3		30520-RS8-004

アコード/アコードワゴン

CD3	F18B	1800	93.09~97.09	U12H01-COIL ●U12H06-COIL	1		30510-PT2-006
CD5	F22B	2200	93.09~97.09	U12H02-COIL	1		30500-POA-A01
CD4	F20B	2000	93.09~97.09	U12H01-COIL ●U12H06-COIL	1		30510-PT2-006
CD6	H22A	2200	93.09~97.09	U12H01-COIL ●U12H06-COIL	1		30510-PT2-006
CD7	F22B	2200	94.06~96.12	U12H02-COIL	1	HITACHI	30500-POA-A01
CD8	H22A	2200	94.06~96.12	U12H01-COIL ●U12H06-COIL	1		30510-PT2-006
CE1	F22B	2200	94.02~97.09	U12H02-COIL	1		30500-POA-A01
CF2	H22A	2200	96.08~97.09	U12H01-COIL ●U12H06-COIL	1		30510-PT2-006
CF3	F18B	1800	97.08~02.10	U12H02-COIL	1		30500-POA-A01
CF4	F20B	2000	97.08~02.10	U12H02-COIL	1	2.0VTS	30500-POA-A01
				U12H01-COIL ●U12H06-COIL	1	SIR,SIR-T	30510-PT2-006
CF5	F20B	2000	97.08~02.10	U12H02-COIL	1		30500-POA-A01
CF6	F23A	2300	97.10~02.11	U12H02-COIL	1		30500-POA-A01
CF7	F23A	2300	97.10~02.11	U12H02-COIL	1		30500-POA-A01
CH9	H23A	2300	98.12~02.11	U12H01-COIL ●U12H06-COIL	1		30510-PT2-006
CL1	H22A	2200	00.06~02.10	U12H01-COIL ●U12H06-COIL	1		30510-PT2-006
CL2	H23A	2300	00.06~02.11	U12H01-COIL ●U12H06-COIL	1		30510-PT2-006
CL3	F20B	2000	00.06~02.10	U12H02-COIL	1		30500-POA-A01
CL7	K20A	2000	02.10~08.12	U14H01-COIL	4		30520-PNC-004
CL8	K20A	2000	02.10~08.12	U14H01-COIL	4		30520-PNC-004
CL9	K24A	2400	02.10~08.12	U14H01-COIL	4		30520-PNC-004
CM1	K20A	2000	04.10~08.12	U14H01-COIL	4		30520-PNC-004
CM2	K24A	2400	02.11~08.12	U14H01-COIL	4		30520-PNC-004
CM3	K24A	2400	02.11~08.12	U14H01-COIL	4		30520-PNC-004
CR7	LFA	2000	13.06~	U16H07-COIL	4	Hybrid	30520-59B-013
CU1	R20A	2000	11.02~13.03	U20H03-COIL	4	2WD	30520-RNA-A01
CW1	R20A	2000	11.02~13.03	U20H03-COIL	4	TOURER 2WD	30520-RNA-A01

アスコット

CC4	H23A	2300	92.03~97.09	U12H01-COIL ●U12H06-COIL	1		30510-PT2-006
CC5	H23A	2300	92.03~97.09	U12H01-COIL ●U12H06-COIL	1		30510-PT2-006

インサイト

ZE2	LDA	1300	09.02~14.04	U09010-COIL	4	Front	30520-RBJ-003
				U09009-COIL	4	Rear	30521-RBJ-003
ZE3	LEA	1500	11.11~14.04	U09005-COIL	4		30520-RB0-013

●印：生産終了品

トヨタ TOYOTA
日産 NISSAN
ホンダ HONDA
マツダ MAZDA
スバル SUBARU
三菱 MITSUBISHI
スズキ SUZUKI
ダイハツ DAIHATSU
いすゞ ISUZU
対照表-1 純正品番順
対照表-2 Astemo品番順

ホンダ

HONDA

車両型式	エンジン型式	排気量	年式	Astemo品番	使用数	類別内容	適応純正品番(参考)
------	--------	-----	----	----------	-----	------	------------

インスパイア/インスパイアルマス

CP3	J35A	3500	07.12~12.09	U09002-COIL	6		30520-R70-A01
UA4	J25A	2500	98.10~03.06	U09001-COIL	6		30520-P8E-A01
UA5	J32A	3200	98.10~03.06	U09001-COIL	6		30520-P8E-A01
UC1	J30A	3000	03.06~04.11	U09001-COIL	6	EngineNo~6010288	30520-P8E-A01
			03.06~04.01	U09001-COIL	6	EngineNo6012815~	30520-RCA-A02
			04.01~07.12	U09001-COIL	6		30520-RCA-A02

インテグラ

DB1	B18B	1800	91.10~93.07	U12H01-COIL (●U12H06-COIL)	1		30510-PT2-006
DB6	ZC	1600	93.07~00.09	U12H01-COIL (●U12H06-COIL)	1	PFI	30510-PT2-006
DB7	B18B	1800	93.07~95.09	U12H01-COIL (●U12H06-COIL)	1		30510-PT2-006
DB8	B18C	1800	93.07~99.07	U12H01-COIL	1	SiR-G	30510-P73-A02
				(●U12H06-COIL)	1	Si VTEC,MT	30510-PT2-006
			93.07~98.01	U12H01-COIL (●U12H06-COIL)	1	Si VTEC,AT	30510-PT2-006
			99.07~00.09	U12H01-COIL	1	SiR-G	30510-P73-A02
DB9	ZC	1600	93.07~00.09	U12H01-COIL (●U12H06-COIL)	1		30510-PT2-006
DC2	B18C	1800	93.05~99.07	U12H01-COIL	1	SiR	30510-P73-A02
			93.05~98.01	U12H01-COIL (●U12H06-COIL)	1	Si	30510-PT2-006
			99.07~00.09	U12H01-COIL	1	SiR-G	30510-P73-A02
DC5	K20A	2000	01.07~07.02	U14H01-COIL	4	iS TypeR	30520-PNA-007 30520-PNA-007

ヴェゼル

RU1	L15B	1500	13.12~	U16H04-COIL	4		30520-5R0-003
RU2	L15B	1500	13.12~	U16H04-COIL	4		30520-5R0-003
RU3	LEB	1500	13.12~	U16H04-COIL	4	Hybrid	30520-5R0-003
RU4	LEB	1500	13.12~	U16H04-COIL	4	Hybrid	30520-5R0-003

エアウェイブ

GJ1	L15A	1500	05.04~10.08	U09008-COIL	4		30520-PWC-003
GJ2	L15A	1500	05.04~10.08	U09008-COIL	4		30520-PWC-003

エディックス

BE1	D17A	1700	04.07~06.12	U09001-COIL	4		30520-PGK-A01
BE2	D17A	1700	04.07~06.12	U09001-COIL	4		30520-PGK-A01
BE3	K20A	2000	04.07~09.08	U14H01-COIL	4		30520-PNA-007
BE4	K20A	2000	04.07~09.08	U14H01-COIL	4		30520-PNA-007
BE8	K24A	2400	06.12~09.08	U14H01-COIL	4		30520-RRA-007

エリシオン/エリシオンプレステージ

RR1	K24A	2400	04.05~13.10	U14H01-COIL	4		30520-PNA-007
RR2	K24A	2400	04.05~13.10	U14H01-COIL	4		30520-PNA-007
RR3	J30A	3000	04.05~10.11	U09001-COIL	6		30520-RCA-A01
RR4	J30A	3000	04.05~10.11	U09001-COIL	6		30520-RCA-A01
RR5	J35A	3500	07.01~13.10	U09001-COIL	6		30520-RCA-A02

西暦	1994	95	96	97	98	99	2000	01	02	03	04	05	06	07	08	09	10	11	12	13	14	15	16	17	18	19	20	21	22	23	24	25	26
和暦	平成6	7	8	9	10	11	12	13	14	15	16	17	18	19	20	21	22	23	24	25	26	27	28	29	30	令和元年	2	3	4	5	6	7	8

TOYOTA
トヨタ

NISSAN
日産

HONDA
ホンダ

MAZDA
マツダ

SUBARU
スバル

MITSUBISHI
三菱

SUZUKI
スズキ

DAIHATSU
ダイハツ

ISUZU
いすゞ

純正品番
対照表-1

Astemo品番
対照表-2

ホンダ

HONDA

車両型式	エンジン型式	排気量	年式	Astemo品番	使用数	類別内容	適応純正品番 (参考)
------	--------	-----	----	----------	-----	------	----------------

エリシオン/エリシオンプレステージ

RR6	J35A	3500	07.01~13.10	U09001-COIL	6		30520-RCA-A02
-----	------	------	-------------	-------------	---	--	---------------

エレメント

YH2	K24A	2400	03.04~05.12	U14H01-COIL	4		30520-PNA-007
-----	------	------	-------------	-------------	---	--	---------------

オデッセイ

RA1	F22B	2200	94.09~97.08	U12H01-COIL (●U12H06-COIL)	1		30510-PT2-006
RA2	F22B	2200	94.09~97.08	U12H01-COIL (●U12H06-COIL)	1		30510-PT2-006
RA3	F23A	2300	97.08~99.12	U12H02-COIL	1		30500-PCA-003
RA4	F23A	2300	97.08~99.12	U12H02-COIL	1		30500-PCA-003
RA8	J30A	3000	00.01~03.10	U09001-COIL	6		30520-P8E-A01
RA9	J30A	3000	00.01~03.10	U09001-COIL	6		30520-P8E-A01
RB1	K24A	2400	03.10~08.10	U14H01-COIL	4		30520-PNA-007
RB2	K24A	2400	03.10~08.10	U14H01-COIL	4		30520-PNA-007
RB3	K24A	2400	08.01~13.11	U17H01-COIL	4		30520-R40-007
RB4	K24A	2400	08.01~13.11	U17H01-COIL	4	4WD	30520-R40-007
RC1	K24W	2400	13.11~	U22H02-COIL	4	FF	30520-5A2-A01
RC2	K24W	2400	13.11~	U22H02-COIL	4	4WD	30520-5A2-A01
RC4	LFA	2000	16.02~	U16H07-COIL	4	Hybrid	30520-59B-013

オデッセイ F.D/T.H

RA3	F23A	2300	97.08~99.12	U12H02-COIL	1	7ル-ムNo.5000001~5100000	30500-PCA-003
RA4	F23A	2300	97.08~99.12	U12H02-COIL	1	7ル-ムNo.5000001~5100000	30500-PCA-003

オルティア

EL1	B18B	1800	96.02~99.06	U12H01-COIL (●U12H06-COIL)	1		30510-PT2-006
EL2	B20B	2000	96.02~02.01	U12H01-COIL (●U12H06-COIL)	1		30510-PT2-006
EL3	B20B	2000	96.02~02.01	U12H01-COIL (●U12H06-COIL)	1		30510-PT2-006

クイント

AV	ZC	1600	85.10~89.05	U12H09-COIL	1	LS,7ル-ムNo.1100001~	30500-PE0-006
DA1	ZC	1600	85.11~89.05	U12H09-COIL	1	LS,7ル-ムNo.1000001~	30500-PE0-006
DA2	EW	1500	86.10~89.05	U12H09-COIL	1	7ル-ムNo.1000001~	30500-PE0-006

クロスロード

RT1	R18A	1800	07.02~10.08	U20H03-COIL	4	2WD	30520-RNA-A01
RT2	R18A	1800	07.02~10.08	U20H03-COIL	4	2WD	30520-RNA-A01
RT3	R20A	2000	07.02~10.08	U20H03-COIL	4	4WD	30520-RNA-A01
RT4	R20A	2000	07.02~10.08	U20H03-COIL	4	4WD	30520-RNA-A01

グレイス

GM4	LEB	1500	14.12~	U16H04-COIL	4	Hybrid	30520-5R0-013
GM5	LEB	1500	14.12~	U16H04-COIL	4	Hybrid	30520-5R0-013
GM6	L15B	1500	15.06~	U16H04-COIL	4		30520-5R0-013
GM9	L15B	1500	15.06~	U16H04-COIL	4		30520-5R0-013

●印：生産終了品

トヨタ TOYOTA
日産 NISSAN
ホンダ HONDA
マツダ MAZDA
スバル SUBARU
三菱 MITSUBISHI
スズキ SUZUKI
ダイハツ DAIHATSU
いすゞ ISUZU
対照表-1 純正品番
対照表-2 Astemo品番

ホンダ

HONDA

車両型式	エンジン型式	排気量	年式	Astemo品番	使用数	類別内容	適応純正品番 (参考)
------	--------	-----	----	----------	-----	------	----------------

ザッツ

JD1	E07Z	660	02.02~07.10	U09001-COIL	3		30520-PXH-004
JD2	E07Z	660	02.02~07.10	U09001-COIL	3		30520-PXH-004

シビック/シビックタイプR

EG4	D15B	1500	91.08~95.09	U12H01-COIL (●U12H06-COIL)	1	PF1	30510-PT2-006
EG5	ZC	1600	92.05~95.09	U12H01-COIL (●U12H06-COIL)	1	PF1	30510-PT2-006
EG6	B16A	1600	91.08~95.09	U12H01-COIL (●U12H06-COIL)	1	PF1	30510-PT2-006
EJ1	D16A	1600	93.02~96.01	U12H01-COIL (●U12H06-COIL)	1	PF1	30510-PT2-006
EJ7	D16A	1600	96.01~97.08	U12H02-COIL	1	PFI	30500-POA-A01
			98.04~99.02	U12H01-COIL (●U12H06-COIL)	1	CNG	30510-PT2-006
EK3	D15B	1500	95.08~00.09	U12H01-COIL (●U12H06-COIL)	1		30510-PT2-006
EK4	B16A	1600	95.08~00.09	U12H01-COIL (●U12H06-COIL)	1		30510-PT2-006
EK9	B16B	1600	97.07~00.09	U12H01-COIL	1		30510-P73-A01
EN2	D17A	1700	01.01~05.05	U09001-COIL	4		30520-PVJ-A01
EP3	K20A	2000	01.12~05.09	U14H01-COIL	4		30520-PNA-007
ES9	LDA	1300	01.11~05.05	U09006-COIL	4	Hybrid,Rear	30521-PWA-003
				U09007-COIL	4	Hybrid,Front	30520-PWA-003
EU1	D15B	1500	00.09~03.09	U09001-COIL	4		30520-PGK-A01
EU2	D15B	1500	00.09~03.09	U09001-COIL	4		30520-PGK-A01
EU3	D17A	1700	00.09~05.09	U09001-COIL	4		30520-PGK-A01
EU4	D17A	1700	00.09~05.09	U09001-COIL	4		30520-PGK-A01
FD1	R18A	1800	05.09~12.06	U20H03-COIL	4	2WD	30520-RNA-A01
FD2	K20A	2000	06.04~10.08	U14H01-COIL	4	2.0GL	30520-RRA-007
			07.03~10.08	U14H01-COIL	4	TypeR	30520-RRA-007
FD3	LDA	1300	05.11~10.12	U09006-COIL	8	Hybrid	30521-PWA-003
FN2	K20A	2000	09.11~12.06	U14H01-COIL	4	TypeR	30520-RRA-007
FK2	K20C	2000	15.02~16.06	U16H07-COIL	4		30520-59B-013

シビックフェリオ

EG8	D15B	1500	91.08~95.08	U12H01-COIL (●U12H06-COIL)	1	PF1	30510-PT2-006
EG9	D16A	1600	91.08~95.08	U12H01-COIL (●U12H06-COIL)	1	PF1	30510-PT2-006
EH1	ZC	1600	91.08~95.08	U12H01-COIL (●U12H06-COIL)	1	PF1	30510-PT2-006
EJ3	ZC	1600	93.09~95.08	U12H01-COIL (●U12H06-COIL)	1	PF1	30510-PT2-006
EK3	D15B	1500	95.08~00.09	U12H01-COIL (●U12H06-COIL)	1		30510-PT2-006
EK8	D16A	1600	97.01~98.08	U12H01-COIL (●U12H06-COIL)	1		30510-PT2-006
EN1	D16A	1600	99.02~01.01	U12H01-COIL (●U12H06-COIL)	1	CNG	30510-PT2-006
EN2	D17A	1700	01.01~05.05	U09001-COIL	4		30520-PGK-A01
ES1	D15B	1500	00.09~05.09	U09001-COIL	4		30520-PGK-A01
ES2	D15B	1500	00.09~05.09	U09001-COIL	4		30520-PGK-A01

西暦	1994	95	96	97	98	99	2000	01	02	03	04	05	06	07	08	09	10	11	12	13	14	15	16	17	18	19	20	21	22	23	24	25	26
和暦	平成6	7	8	9	10	11	12	13	14	15	16	17	18	19	20	21	22	23	24	25	26	27	28	29	30	令和元年	2	3	4	5	6	7	8

TOYOTA
トヨタ

NISSAN
日産

HONDA
ホンダ

MAZDA
マツダ

SUBARU
スバル

DAIHATSU
ダイハツ

SUZUKI
スズキ

ISUZU
いすゞ

純正品番
対照表-1

Astemo品番
対照表-2

ホンダ

HONDA

車両型式	エンジン型式	排気量	年式	Astemo品番	使用数	類別内容	適応純正品番 (参考)
------	--------	-----	----	----------	-----	------	----------------

シビックフェリオ

ES3	D17A	1700	00.09~05.09	U09001-COIL	4		30520-PGK-A01
ES9	LDA	1300	01.11~05.05	U09007-COIL	4	Hybrid,Front	30520-PWA-003
				U09006-COIL	4	Hybrid,Rear	30521-PWA-003
ET2	D17A	1700	03.09~05.09	U09001-COIL	4		30520-PGK-A01

ジェイド

FR4	LEB	1500	15.02~	U16H04-COIL	4	Hybrid	30520-5R0-013
FR5	L15B	1500	15.05~	U16H07-COIL	4	TURBO	30520-59B-013

ステップワゴン

RF1	B20B	2000	96.05~01.04	U12H01-COIL (●U12H06-COIL)	1		30510-PT2-006
RF2	B20B	2000	96.05~01.04	U12H01-COIL (●U12H06-COIL)	1		30510-PT2-006
RF3	K20A	2000	01.04~05.05	U14H01-COIL	4		30520-PNC-004
RF4	K20A	2000	01.04~05.05	U14H01-COIL	4		30520-PNC-004
RF7	K24A	2400	03.06~05.05	U14H01-COIL	4		30520-PNC-004
RF8	K24A	2400	03.06~05.05	U14H01-COIL	4		30520-PNC-004
RG1	K20A	2000	05.05~09.10	U14H01-COIL	4		30520-PNC-004
RG2	K20A	2000	05.05~09.10	U14H01-COIL	4		30520-PNC-004
RG3	K24A	2400	05.05~07.11	U14H01-COIL	4		30520-PNC-004
RG4	K24A	2400	05.05~07.11	U14H01-COIL	4		30520-PNC-004
RK1	R20A	2000	09.10~15.04	U20H03-COIL	4	2WD	30520-RNA-A01
			10.10~11.08	U20H03-COIL	4	4WD	30520-RNA-A01
RK2	R20A	2000	09.10~13.12	U20H03-COIL	4	2WD	30520-RNA-A01
			09.10~15.04	U20H03-COIL	4	4WD	30520-RNA-A01
RK3	R20A	2000	09.10~15.04	U20H03-COIL	4	2WD	30520-RNA-A01
RK4	R20A	2000	09.10~15.04	U20H03-COIL	4	4WD	30520-RNA-A01
RP1	L15B	1500	15.04~	U16H07-COIL	4	TURBO	30520-59B-013
RP2	L15B	1500	15.04~	U16H07-COIL	4	TURBO	30520-59B-013

ステップワゴン スパーダ

RF5	K20A	2000	03.06~05.05	U14H01-COIL	4		30520-PNC-004
RF6	K20A	2000	03.06~05.05	U14H01-COIL	4		30520-PNC-004
RF7	K24A	2400	03.06~05.05	U14H01-COIL	4		30520-RWC-A01
RF8	K24A	2400	03.06~05.05	U14H01-COIL	4		30520-RWC-A01
RG1	K20A	2000	07.11~09.10	U14H01-COIL	4		30520-RWC-A01
RG2	K20A	2000	07.11~09.10	U14H01-COIL	4		30520-RWC-A01
RG3	K24A	2400	07.11~09.10	U14H01-COIL	4		30520-RWC-A01
RG4	K24A	2400	07.11~09.10	U14H01-COIL	4		30520-RWC-A01
RK5	R20A	2000	09.10~15.04	U20H03-COIL	4	2WD	30520-RNA-A01
			09.10~11.08	U20H03-COIL	4	4WD	30520-RNA-A01
			09.10~15.04	U20H03-COIL	4		30520-RNA-S01
RK6	R20A	2000	09.10~15.04	U20H03-COIL	4	4WD	30520-RNA-A01
RK7	R20A	2000	09.10~15.04	U20H03-COIL	4	2WD	30520-RNA-A01
RP3	L15B	1500	15.04~	U16H07-COIL	4	TURBO	30520-59B-013
RP4	L15B	1500	15.04~	U16H07-COIL	4	TURBO	30520-59B-013

ストリート

HH1	E05A	550	88.05~90.03	U12H09-COIL	1		30500-PE0-006
HH2	E05A	550	88.05~90.03	U12H09-COIL	1		30500-PE0-006
HH3	E07A	660	90.02~99.06	U12H09-COIL	1		30500-PE0-006

●印：生産終了品

トヨタ TOYOTA
日産 NISSAN
ホンダ HONDA
マツダ MAZDA
スバル SUBARU
三菱 MITSUBISHI
スズキ SUZUKI
ダイハツ DAIHATSU
いすゞ ISUZU
対照表-1 純正品番
対照表-2 Astemo品番

ホンダ

HONDA

車両型式	エンジン型式	排気量	年式	Astemo品番	使用数	類別内容	適応純正品番 (参考)
------	--------	-----	----	----------	-----	------	----------------

ストリート

HH4	E07A	660	90.02~99.06	U12H09-COIL	1		30500-PE0-006
RN1	D17A	1700	00.10~06.07	U09001-COIL	4		30520-PGK-A01
RN2	D17A	1700	00.10~06.07	U09001-COIL	4		30520-PGK-A01
RN3	K20A	2000	00.10~06.07	U14H01-COIL	4		30520-PNA-007
RN4	K20A	2000	01.01~06.07	U14H01-COIL	4		30520-PNA-007
RN5	K20B	2000	03.12~06.07	U09003-COIL	4		30520-PPD-003
RN6	R18A	1800	06.07~14.05	U20H03-COIL	4	2WD	30520-RNA-A01
			12.04~14.05	U20H03-COIL	4	4WD	30520-RNA-A01
RN7	R18A	1800	12.04~14.05	U20H03-COIL	4	2WD	30520-RNA-A01
			06.07~14.05	U20H03-COIL	4	4WD	30520-RNA-A01
RN8	R20A	2000	06.07~14.05	U20H03-COIL	4	2WD	30520-RNA-A01
RN9	R20A	2000	06.07~14.05	U20H03-COIL	4	4WD	30520-RNA-A01

セイバー

UA4	J25A	2500	98.10~03.06	U09001-COIL	6		30520-P8E-S01
UA5	J32A	3200	98.10~03.06	U09001-COIL	6		30520-P8E-S01

ゼスト/ゼスト スパーク

JE1	P07A	660	06.03~08.12	U09001-COIL	6		30520-RGA-004
			08.12~12.11	U15H01-COIL	6		30520-RS8-004
JE2	P07A	660	06.03~08.12	U09001-COIL	6		30520-RGA-004
			08.12~12.11	U15H01-COIL	6		30520-RS8-004

トルネオ

CF3	F18B	1800	97.08~02.10	U12H02-COIL	1		30500-PCA-003
CF4	F20B	2000	97.08~02.10	U12H02-COIL	1	20VTS,MT	30500-PCA-003
				U12H01-COIL (●U12H06-COIL)	1	SiR,AT	30510-PT2-006
CF5	F20B	2000	97.08~02.10	U12H02-COIL	1		30500-PCA-003
CL3	F20B	2000	00.06~02.10	U12H02-COIL	1		30500-PCA-003

ドマーニ

MA4	ZC	1600	92.10~97.01	U12H01-COIL (●U12H06-COIL)	1		30510-PT2-006
MA5	B18B	1800	92.10~97.01	U12H01-COIL (●U12H06-COIL)	1		30510-PT2-006
MA6	ZC	1600	92.10~97.01	U12H01-COIL (●U12H06-COIL)	1		30510-PT2-006
MA7	D15B	1500	94.02~97.01	U12H01-COIL (●U12H06-COIL)	1		30510-PT2-006
MB3	D15B	1500	97.01~00.08	U12H01-COIL (●U12H06-COIL)	1		30510-PT2-006
MB4	D16A	1600	97.01~00.08	U12H01-COIL (●U12H06-COIL)	1		30510-PT2-006

バモス

HM1	E07Z	660	99.05~10.08	U09001-COIL	3		30520-PFE-004
			10.08~18.05	U15H01-COIL	3		30520-RS8-004
HM2	E07Z	660	99.05~10.08	U09001-COIL	3		30520-PFE-004
			10.08~18.05	U15H01-COIL	3		30520-RS8-004

西暦	1994	95	96	97	98	99	2000	01	02	03	04	05	06	07	08	09	10	11	12	13	14	15	16	17	18	19	20	21	22	23	24	25	26
和暦	平成6	7	8	9	10	11	12	13	14	15	16	17	18	19	20	21	22	23	24	25	26	27	28	29	30	令和元年	2	3	4	5	6	7	8

TOYOTA
トヨタ

NISSAN
日産

HONDA
ホンダ

MAZDA
マツダ

SUBARU
スバル

MITSUBISHI
三菱

SUZUKI
スズキ

DAIHATSU
ダイハツ

ISUZU
いすゞ

純正品番
対照表-1

Astemo品番
対照表-2

ホンダ

HONDA

車両型式	エンジン型式	排気量	年式	Astemo品番	使用数	類別内容	適応純正品番(参考)
------	--------	-----	----	----------	-----	------	------------

バモス ホビオ

HJ1	E07Z	660	03.04~10.08	U09001-COIL	3		30520-PXH-004
			10.08~18.05	U15H01-COIL	3		30520-RS8-004
HJ2	E07Z	660	03.04~10.08	U09001-COIL	3		30520-PXH-004
			10.08~18.05	U15H01-COIL	3		30520-RS8-004
HM3	E07Z	660	03.04~10.08	U09001-COIL	3		30520-PXH-004
			10.08~18.05	U15H01-COIL	3		30520-RS8-004
HM4	E07Z	660	03.04~10.08	U09001-COIL	3		30520-PXH-004
			10.08~18.05	U15H01-COIL	3		30520-RS8-004

パートナー

EY7	D15B	1500	96.02~06.03	U12H01-COIL ●U12H06-COIL	1		30510-PT2-006
EY8	D16A	1600	96.02~06.03	U12H01-COIL ●U12H06-COIL	1		30510-PT2-006
EY9	D16A	1600	97.02~99.05	U12H01-COIL ●U12H06-COIL	1		30510-PT2-006
GJ3	L15A	1500	06.03~10.08	U09007-COIL	4	Front	30520-PWA-003
				U09006-COIL	4	Rear	30521-PWA-003
GJ4	L15A	1500	06.07~10.08	U09007-COIL	4	Front	30520-PWA-003
				U09006-COIL	4	Rear	30521-RLB-003

フィット

GD1	L13A	1300	01.06~07.10	U09007-COIL	4	Front	30520-PWA-003
				U09006-COIL	4	Rear	30521-PWA-003
GD2	L13A	1300	01.06~07.10	U09007-COIL	4	Front	30520-PWA-003
				U09006-COIL	4	Rear	30521-PWA-003
GD3	L15A	1500	02.09~07.10	U09008-COIL	4		30520-PWC-003
GD4	L15A	1500	02.09~07.10	U09008-COIL	4		30520-PWC-003
GE6	L13A	1300	07.10~13.09	U09005-COIL	4		30520-RB0-003
GE7	L13A	1300	07.10~13.09	U09005-COIL	4		30520-RB0-003
GE8	L15A	1500	07.10~13.09	U09005-COIL	4		30520-RB0-003
GE9	L15A	1500	07.10~13.09	U09005-COIL	4		30520-RB0-003
GK3	L13B	1300	13.09~20.01	U16H04-COIL	4		30520-5R0-003
GK4	L13B	1300	13.09~20.01	U16H04-COIL	4		30520-5R0-003
GK5	L15B	1500	13.09~20.01	U16H04-COIL	4		30520-5R0-003
GK6	L15B	1500	13.09~20.01	U16H04-COIL	4		30520-5R0-003
GP1	LDA	1300	10.10~13.09	U09010-COIL	4	Hybrid,Front	30520-RBJ-003
				U09009-COIL	4	Hybrid,Rear	30521-RBJ-003
GP4	LEA	1500	12.05~13.09	U09005-COIL	4	Hybrid	30520-RB0-S01
GP5	LEB	1500	13.09~	U16H04-COIL	4	Hybrid	30520-5R0-003
GP6	LEB	1500	13.09~	U16H04-COIL	4	Hybrid	30520-5R0-003

フィット アリア

GD6	L13A	1300	02.11~05.10	U09007-COIL	4	Front	30520-PWA-003
				U09006-COIL	4	Rear	30521-PWA-003
GD7	L13A	1300	02.11~05.10	U09007-COIL	4	Front	30520-PWA-003
				U09006-COIL	4	Rear	30521-PWA-003
GD8	L15A	1500	02.11~05.10	U09007-COIL	4	Front	30520-PWA-003
				U09006-COIL	4	Rear	30521-PWA-003
GD9	L15A	1500	02.11~05.10	U09008-COIL	4		30520-PWC-003
				U09007-COIL	4	Front	30520-PWA-003
				U09006-COIL	4	Rear	30521-PWA-003
GD9	L15A	1500	05.10~09.01	U09008-COIL	4		30520-PWC-003
				U09007-COIL	4	Front	30520-PWA-003
GD9	L15A	1500	05.10~09.01	U09006-COIL	4	Rear	30521-PWA-003
				U09008-COIL	4		30520-PWC-003

●印：生産終了品

トヨタ TOYOTA
日産 NISSAN
ホンダ HONDA
マツダ MAZDA
スバル SUBARU
三菱 MITSUBISHI
スズキ SUZUKI
ダイハツ DAIHATSU
いすゞ ISUZU
対照表-1 純正品番順
対照表-2 Astemo品番順

ホンダ

HONDA

車両型式	エンジン型式	排気量	年式	Astemo品番	使用数	類別内容	適応純正品番(参考)
------	--------	-----	----	----------	-----	------	------------

フィットアルマス

GD1	L13A	1300	01.06~05.12	U09007-COIL	4	Front	30520-PWA-003
				U09006-COIL	4	Rear	30521-PWA-003
GD2	L13A	1300	01.06~05.12	U09007-COIL	4	Front	30520-PWA-003
				U09006-COIL	4	Rear	30521-PWA-003
GD3	L15A	1500	02.09~05.12	U09008-COIL	4		30520-PWC-003
GD4	L15A	1500	02.09~05.12	U09008-COIL	4		30520-PWC-003

フィットシャトル

GG7	L15A	1500	11.03~15.03	U09005-COIL	4		30520-RB0-003
GG8	L15A	1500	11.03~15.03	U09005-COIL	4		30520-RB0-003
GK8	L15B	1500	15.05~	U16H04-COIL	4		30520-5R0-013
GK9	L15B	1500	15.05~	U16H04-COIL	4		30520-5R0-013
GP2	LDA	1300	11.03~15.03	U09010-COIL	4	Hybrid,Front	30520-RBJ-003
				U09009-COIL	4	Hybrid,Rear	30521-RBJ-003
GP7	LEB	1500	15.05~	U16H04-COIL	4	Hybrid	30520-5R0-013
GP8	LEB	1500	15.05~	U16H04-COIL	4	Hybrid	30520-5R0-013

フリード

GB3	L15A	1500	08.05~	U09005-COIL	4		30520-RB0-003
GB4	L15A	1500	08.05~16.09	U09005-COIL	4		30520-RB0-003
GB5	L15B	1500	16.09~	U16H04-COIL	4		30520-5R0-013
GB6	L15B	1500	16.09~	U16H04-COIL	4		30520-5R0-013
GB7	LEB	1500	16.09~	U16H04-COIL	4	Hybrid	30520-5R0-013
GB8	LEB	1500	16.09~	U16H04-COIL	4	Hybrid	30520-5R0-013
GP3	LEA	1500	11.10~16.09	U09010-COIL	4	Hybrid,Front	30520-RBJ-013
				U09009-COIL	4	Hybrid,Rear	30521-RBJ-013

フリードスパイク

GB3	L15A	1500	10.07~16.09	U09005-COIL	4		30520-RB0-003
GB4	L15A	1500	11.10~16.09	U09005-COIL	4		30520-RB0-003
GP3	LEA	1500	11.10~16.09	U09010-COIL	4	Hybrid,Front	30520-RBJ-013
				U09009-COIL	4	Hybrid,Rear	30521-RBJ-013

フリード+(プラス)

GB5	L15B	1500	16.09~	U16H04-COIL	4		30520-5R0-013
GB6	L15B	1500	16.09~	U16H04-COIL	4		30520-5R0-013
GB7	LEB	1500	16.09~	U16H04-COIL	4	Hybrid	30520-5R0-013
GB8	LEB	1500	16.09~	U16H04-COIL	4	Hybrid	30520-5R0-013

プレリユード

BA4	B20A	2000	87.04~91.09	U12H09-COIL	1		30500-PE0-006
BA5	B20A	2000	87.04~91.09	U12H09-COIL	1		30500-PE0-006
BA7	B21A	2100	90.10~91.09	U12H09-COIL	1		30500-PE0-006
BA8	F22B	2200	91.09~96.11	U12H01-COIL	1		30510-PT2-006
				(●)U12H06-COIL			
BA9	F22B	2200	91.09~96.11	U12H01-COIL	1		30510-PT2-006
				(●)U12H06-COIL			
BB1	H22A	2200	91.09~96.11	U12H01-COIL	1		30510-PT2-006
BB4	H22A	2200	91.09~96.11	U12H01-COIL	1		30510-PT2-006
				(●)U12H06-COIL			

西暦	1994	95	96	97	98	99	2000	01	02	03	04	05	06	07	08	09	10	11	12	13	14	15	16	17	18	19	20	21	22	23	24	25	26
和暦	平成6	7	8	9	10	11	12	13	14	15	16	17	18	19	20	21	22	23	24	25	26	27	28	29	30	令和元年	2	3	4	5	6	7	8

TOYOTA
トヨタ

NISSAN
日産

HONDA
ホンダ

MAZDA
マツダ

SUBARU
スバル

MITSUBISHI
三菱

SUZUKI
スズキ

DAIHATSU
ダイハツ

ISUZU
いすゞ

純正品番
対照表-1

Astemo品番
対照表-2

ホンダ

HONDA

車両型式	エンジン型式	排気量	年式	Astemo品番	使用数	類別内容	適応純正品番 (参考)
------	--------	-----	----	----------	-----	------	----------------

プレリウド

BB5	F22B	2200	96.10~00.08	U12H01-COIL ●U12H06-COIL	1		30510-PT2-006
BB6	H22A	2200	96.10~00.08	U12H01-COIL ●U12H06-COIL	1		30510-PT2-006
BB7	F22B	2200	96.10~00.08	U12H01-COIL ●U12H06-COIL	1		30510-PT2-006
BB8	H22A	2200	96.10~00.08	U12H01-COIL ●U12H06-COIL	1		30510-PT2-006

モビリオ

GB1	L15A	1500	01.12~08.07	U09007-COIL	4	Front	30520-PWA-003
				U09006-COIL	4	Rear	30521-PWA-003
			04.01~08.07	U09008-COIL	4	X,XT	30520-PWC-003
GB2	L15A	1500	01.12~08.07	U09007-COIL	4	Front	30520-PWA-003
				U09006-COIL	4	Rear	30521-PWA-003

モビリオ アルマス

GB1	L15A	1500	03.07~08.06	U09007-COIL	4	Front,GB1-800,820,840	30520-PWA-003
				U09006-COIL	4	Rear,GB1-800,820,840	30521-PWA-003
			04.07~08.06	U09008-COIL	4	GB1-810,830	30520-PWC-003
GB2	L15A	1500	04.07~08.06	U09007-COIL	4	Front,GB2-810,820	30520-PWA-003
				U09006-COIL	4	Rear,GB2-810,820	30521-PWA-003

モビリオ スパイク

GK1	L15A	1500	02.09~08.07	U09008-COIL	4		30520-PWC-003
GK2	L15A	1500	02.09~08.07	U09008-COIL	4		30520-PWC-003

ライフ

JB1	E07Z	660	98.10~03.09	U09001-COIL	3		30520-PFB-007
JB2	E07Z	660	98.10~03.09	U09001-COIL	3		30520-PFB-007
JB3	E07Z	660	00.12~03.09	U09001-COIL	3	TURBO	30520-PXH-004
JB4	E07Z	660	00.12~03.09	U09001-COIL	3	TURBO	30520-PXH-004
JB5	P07A	660	03.09~08.11	U09001-COIL	6		30520-PXH-004
JB6	P07A	660	03.09~08.11	U09001-COIL	6		30520-PXH-004
JB7	P07A	660	03.09~08.11	U09001-COIL	6	TURBO	30520-PXH-004
JB8	P07A	660	03.09~08.11	U09001-COIL	6	TURBO	30520-PXH-004
JC1	P07A	660	08.11~14.04	U15H01-COIL	6		30520-RS8-004
JC2	P07A	660	08.11~14.04	U15H01-COIL	6		30520-RS8-004

ラグレイト

RL1	J35A	3500	99.06~04.05	U09001-COIL	6		30520-P8E-A01
-----	------	------	-------------	-------------	---	--	---------------

レジェンド

KB1	J35A	3500	04.10~08.12	U09001-COIL	6		30520-RCA-A02
KB2	J37A	3700	08.09~12.07	U09002-COIL	6		30520-R70-A01

●印：生産終了品

トヨタ TOYOTA
日産 NISSAN
ホンダ HONDA
マツダ MAZDA
スバル SUBARU
三菱 MITSUBISHI
スズキ SUZUKI
ダイハツ DAIHATSU
いすゞ ISUZU
対照表-1 純正品番順
対照表-2 Astemo品番順

マツダ

MAZDA

車両型式	エンジン型式	排気量	年式	Astemo品番	使用数	類別内容	適応純正品番 (参考)
------	--------	-----	----	----------	-----	------	----------------

AZ-オフロード

JM23W	K6A	660	98.10~14.03	U21S02-COIL (●U12S01-COIL)	3	TURBO	1A05-18-100
-------	-----	-----	-------------	-------------------------------	---	-------	-------------

AZ-ワゴン/AZ-ワゴン カスタムスタイル

MD11S	F6A	660	98.10~00.11	U21S02-COIL (●U12S01-COIL)	3	EPI	1A05-18-100
MD12S	F6A	660	00.12~01.11	U21S02-COIL (●U12S01-COIL)	3		1A09-18-100
MD21S	K6A	660	98.10~00.11	U21S02-COIL (●U12S01-COIL)	3	EPI	1A05-18-100
MD22S	K6A	660	00.12~03.09	U21S02-COIL (●U12S01-COIL)	3		1A05-18-100A
MJ21S	K6A	660	03.10~07.05	U21S02-COIL (●U12S01-COIL)	3		1A05-18-100A
MJ22S	K6A	660	07.02~08.09	U21S02-COIL (●U12S01-COIL)	3		1A05-18-100A
MJ23S	K6A	660	08.09~12.10	U21S02-COIL (●U12S01-COIL)	3		1A07-18-100A

CX-7

ER3P	L3VDT	2300	06.12~09.09	U18M03-COIL	4	TURBO	L3G2-18-100A
------	-------	------	-------------	-------------	---	-------	--------------

MAZDA2

DJLAS	P5-VPS	1500	19.07~	U21M01-COIL	4		P51R-18-100
DJLFS	P5-VPS	1500	19.07~	U21M01-COIL	4		P51R-18-100

MPV

LW3W	L3	2300	02.03~03.10	U12M01-COIL	1	EGI	L813-18-100
	L3DE	2300	03.10~05.12	U12M01-COIL	1	EGI	L813-18-100
LY3P	L3VDT	2300	05.12~07.12	U18M03-COIL	4	TURBO	L3G2-18-100A
	L3VE	2300	05.12~07.12	U18M03-COIL	4	EGI	L3G2-18-100A

RX-8

SE3P	13BMSP	1300	03.05~04.09	U15M01-COIL	4	EGI	N3H1-18-100
			08.02~13.04	U15M01-COIL	4	EGI	N3H1-18-100

アクセラ

BK3P	L3VE	2300	06.05~09.06	U18M03-COIL	4	EGI	L3G2-18-100A
BK5P	ZYVE	1500	03.10~06.05	U17M01-COIL	4	EGI	ZJ01-18-100
			03.10~04.05	U19M02-COIL	4		ZJ20-18-100A
BKEP	LFDE	2000	03.10~04.03	U18M04-COIL	4	BKEP-100157,EGI	LF16-18-100
				U18M04-COIL	4	EGI	LF16-18-100B
BKEP	LFDE	2000	04.10~06.05	U18M04-COIL	4	BKEP-100157,EGI	LF16-18-100
				U18M04-COIL	4	EGI	LF16-18-100B
BKEP	LFVE	2000	06.05~09.06	U18M03-COIL	4	EGI	L3G2-18-100A
BL3FW	L3VDT	2300	09.06~13.11	U18M01-COIL	4	MAZDA SPEED	LF2L-18-100A
BL5FP	ZYVE	1500	09.06~13.11	U19M02-COIL	4		ZJ20-18-100A
BL5FW	ZYVE	1500	09.06~13.11	U19M02-COIL	4		ZJ20-18-100A
BLEAP	LFVE	2000	06.05~11.08	U18M03-COIL	4	EGI	L3G2-18-100A
BLEAW	LFVE	2000	06.05~11.08	U18M03-COIL	4	EGI	L3G2-18-100A
BLEFP	LFVDS	2000	09.06~11.08	U18M03-COIL	4	DI	L3G2-18-100A

西暦	1994	95	96	97	98	99	2000	01	02	03	04	05	06	07	08	09	10	11	12	13	14	15	16	17	18	19	20	21	22	23	24	25	26
和暦	平成6	7	8	9	10	11	12	13	14	15	16	17	18	19	20	21	22	23	24	25	26	27	28	29	30	令和元年	2	3	4	5	6	7	8

TOYOTA
トヨタ

NISSAN
日産

HONDA
ホンダ

MAZDA
マツダ

SUBARU
スバル

MITSUBISHI
三菱

SUZUKI
スズキ

DAIHATSU
ダイハツ

ISUZU
いすゞ

純正品番
対照表-1

Astemo品番
対照表-2

マツダ

MAZDA

車両型式	エンジン型式	排気量	年式	Astemo品番	使用数	類別内容	適応純正品番 (参考)
------	--------	-----	----	----------	-----	------	----------------

アクセラ

BLEFW	LFVDS	2000	09.06~11.08	U18M03-COIL	4	DI	L3G2-18-100A
-------	-------	------	-------------	-------------	---	----	--------------

アテンザ

GG3P	L3VE	2300	02.05~05.06	U12M01-COIL	1	EGI	L813-18-100
			05.06~07.12	U18M03-COIL	4	EGI	L3G2-18-100A
GG3S	L3VE	2300	02.05~05.06	U12M01-COIL	1	EGI	L813-18-100
			05.06~07.12	U18M03-COIL	4	EGI	L3G2-18-100A
GGEP	LFDE	2000	02.05~05.06	U12M01-COIL	1	EGI	L813-18-100
	LFVE	2000	05.06~07.12	U18M03-COIL	4	EGI	L3G2-18-100A
GGES	LFDE	2000	02.05~05.06	U12M01-COIL	1	EGI	L813-18-100
	LFVE	2000	05.06~07.12	U18M03-COIL	4	EGI	L3G2-18-100A
GH5AP	L5VE	2500	08.01~12.09	U18M03-COIL	4	EGI	L3G2-18-100A
GH5AS	L5VE	2500	08.01~12.09	U18M03-COIL	4	EGI	L3G2-18-100A
GH5AW	L5VE	2500	08.01~12.09	U18M03-COIL	4	EGI	L3G2-18-100A
GH5FP	L5VE	2500	08.01~12.09	U18M03-COIL	4	EGI	L3G2-18-100A
GH5FS	L5VE	2500	08.01~12.09	U18M03-COIL	4	EGI	L3G2-18-100A
GH5FW	L5VE	2500	08.01~12.09	U18M03-COIL	4	EGI	L3G2-18-100A
GHEFP	LFVE	2000	08.01~12.09	U18M03-COIL	4	EGI	L3G2-18-100A
GHEFS	LFVE	2000	07.12~10.01	U18M03-COIL	4	EGI	L3G2-18-100A
GHEFW	LFVE	2000	08.01~12.09	U18M03-COIL	4	EGI	L3G2-18-100A
GY3W	L3VE	2300	02.05~05.06	U12M01-COIL	1	EGI,~#400000	L813-18-100
			05.06~07.12	U18M03-COIL	4	EGI	L3G2-18-100A
GYEW	LFDE	2000	02.05~05.06	U12M01-COIL	1	EGI,~#400000	L813-18-100
	LFVE	2000	05.06~07.12	U18M03-COIL	4	EGI	L3G2-18-100A

イクシオン

CP8WF	FPDE	1800	99.04~03.01	U15M02-COIL	1	EGI	FP85-18-100B
-------	------	------	-------------	-------------	---	-----	--------------

エスケープ

EP3WF	L3	2300	03.11~05.10	U12M01-COIL	1		L813-18-100
-------	----	------	-------------	-------------	---	--	-------------

カペラ

GF8P	FPDE	1800	97.06~01.03	U15M02-COIL	2	EGI,#200001~#300000	FP85-18-100B
GFEP	FSZE	2000	97.06~02.03	U15M02-COIL	2	EGI,#200001~#300000	FP85-18-100B
GFER	FSDE	2000	97.06~01.03	U15M02-COIL	2	EGI,#200001~#300000	FP85-18-100B
GW8W	FPDE	1800	97.10~02.05	U15M02-COIL	2	EGI,#200001~#300000	FP85-18-100B
GWER	FSDE	2000	97.10~02.05	U15M02-COIL	2	EGI,#200001~#300000	FP85-18-100B
	FSZE	2000	97.10~02.05	U15M02-COIL	2	EGI,#200001~#300000	FP85-18-100B
GWEW	FSZE	2000	97.10~02.05	U15M02-COIL	2	EGI,#200001~#300000	FP85-18-100B

キャロル

HB12S	F6A	660	98.10~00.11	U21S02-COIL ●U12S01-COIL	3	EPI	1A05-18-100
HB22S	K6A	660	98.10~02.04	U21S02-COIL ●U12S01-COIL	3	EPI	1A05-18-100
HB23S	K6A	660	00.12~04.09	U21S02-COIL ●U12S01-COIL	3	EPI	1A05-18-100A
HB24S	K6A	660	04.09~09.12	U21S02-COIL ●U12S01-COIL	3	EPI	1A05-18-100A
HB25S	K6A	660	09.12~15.01	U21S02-COIL ●U12S01-COIL	3	EPI	1A07-18-100A
HB35S	R06A	660	12.11~15.01	U19S01-COIL	3		1A13-18-100

●印：生産終了品

トヨタ
TOYOTA

日産
NISSAN

ホンダ
HONDA

マツダ
MAZDA

スバル
SUBARU

三菱
MITSUBISHI

スズキ
SUZUKI

ダイハツ
DAIHATSU

いすゞ
ISUZU

対照表-1
純正品番順

対照表-2
Astemo品番順

マツダ

MAZDA

車両型式	エンジン型式	排気量	年式	Astemo品番	使用数	類別内容	適応純正品番(参考)
------	--------	-----	----	----------	-----	------	------------

スクラム

DG16T	R06A	660	13.09~	U19S01-COIL	3		1A13-18-100
DG17V	R06A	660	15.02~	U19S01-COIL	3		1A13-18-100
DG17W	R06A	660	15.02~	U19S01-COIL	3		1A13-18-100
DG52T	F6A	660	99.01~01.09	U21S02-COIL (●U12S01-COIL)	3	EPI,除く(TURBO)	1A05-18-100
DG52V	F6A	660	99.01~01.09	U21S02-COIL (●U12S01-COIL)	3	EPI,除く(TURBO)	1A05-18-100
DG62T	K6A	660	01.09~02.05	U21S02-COIL (●U12S01-COIL)	3	EPI,除く(TURBO)	1A05-18-100A
DG62V	K6A	660	01.09~05.09	U21S02-COIL (●U12S01-COIL)	3	EPI,TURBO	1A05-18-100A
DG62W	K6A	660	01.09~05.09	U21S02-COIL (●U12S01-COIL)	3	EPI,TURBO	1A05-18-100A
DG63T	K6A	660	02.05~13.09	U21S02-COIL (●U12S01-COIL)	3	EPI	1A05-18-100A
DG64V	K6A	660	05.09~15.03	U21S02-COIL (●U12S01-COIL)	3	EPI	1A07-18-100
DG64W	K6A	660	05.09~15.03	U21S02-COIL (●U12S01-COIL)	3	EPI,TURBO	1A07-18-100
DH52T	F6A	660	99.01~01.09	U21S02-COIL (●U12S01-COIL)	3	EPI,除く(TURBO)	1A05-18-100
DH52V	F6A	660	99.01~01.09	U21S02-COIL (●U12S01-COIL)	3	EPI,除く(TURBO)	1A05-18-100

スパアーノ

HF21S	K6A	660	02.02~08.09	U21S02-COIL (●U12S01-COIL)	3	EPI,TURBO	1A05-18-100A
-------	-----	-----	-------------	-------------------------------	---	-----------	--------------

デミオ

DE3AS	ZJVE	1300	07.07~14.09	U19M02-COIL	4		ZJ20-18-100A
DE3FS	ZJVE	1300	07.07~14.09	U19M02-COIL	4		ZJ20-18-100A
	ZJVEM	1300	07.07~14.09	U19M02-COIL	4	CVT	ZJ20-18-100A
DE5FS	ZYVE	1500	07.07~14.09	U19M02-COIL	4	(ス*ル含)	ZJ20-18-100A
DJ3FS	PS-VPS	1300	14.06~	U21M01-COIL	4		P51R-18-100
DY3R	ZJVE	1300	03.11~05.04	U17M01-COIL	4	EPI	ZJ01-18-100
			04.06~07.07	U19M02-COIL	4	4WD	ZJ20-18-100A
DY3W	ZJVE	1300	02.06~05.04	U17M01-COIL	4	EPI	ZJ01-18-100
			02.06~03.04	U19M02-COIL	4		ZJ20-18-100A
DY5R	ZYVE	1500	03.11~05.04	U17M01-COIL	4	EPI	ZJ01-18-100
			02.04~04.06	U19M02-COIL	4		ZJ20-18-100A
DY5W	ZYVE	1500	02.06~05.04	U17M01-COIL	4	EPI	ZJ01-18-100
			02.06~07.07	U19M02-COIL	4		ZJ20-18-100A

トリビュート

EP3W	L3	2300	03.12~05.10	U12M01-COIL	1	EPI	L813-18-100
------	----	------	-------------	-------------	---	-----	-------------

ビアンテ

CCEAW	LFVD	2000	08.07~15.09	U18M01-COIL	4		LF2L-18-100A
CCEFW	LFVD	2000	08.07~13.05	U18M01-COIL	4		LF2L-18-100A
	LFVDS	2000	08.07~13.05	U18M01-COIL	4		LF2L-18-100A
CC3FW	L3VE	2000	08.07~13.05	U18M01-COIL	4	23S	LF2L-18-100A

西暦	1994	95	96	97	98	99	2000	01	02	03	04	05	06	07	08	09	10	11	12	13	14	15	16	17	18	19	20	21	22	23	24	25	26
和暦	平成6	7	8	9	10	11	12	13	14	15	16	17	18	19	20	21	22	23	24	25	26	27	28	29	30	令和元年	2	3	4	5	6	7	8

TOYOTA
トヨタ

NISSAN
日産

HONDA
ホンダ

MAZDA
マツダ

SUBARU
スバル

MITSUBISHI
三菱

SUZUKI
スズキ

DAIHATSU
ダイハツ

ISUZU
いすゞ

純正品番
対照表-1

Astemo品番
対照表-2

マツダ

MAZDA

車両型式	エンジン型式	排気量	年式	Astemo品番	使用数	類別内容	適応純正品番(参考)
------	--------	-----	----	----------	-----	------	------------

ファミリア

BJFP	FSZE	2000	01.12~03.09	U15M02-COIL	2	EGI	FP85-18-100C
BJFW	FSZE	2000	99.06~03.09	U15M02-COIL	2	EGI	FP85-18-100C
BVAY12	CR12DE	1200	07.01~13.05	U08108-COIL	4	EGI	1N07-18-100
BVY11	QG15DE	1500	00.01~07.01	U08101-COIL	4	EGI,#510001~	1N01-18-100
BVHNY11	QG18DE	1800	00.01~07.01	U08101-COIL	4	EGI,#510001~	1N01-18-100
BVY11	QG13DE	1300	00.01~07.01	U08101-COIL	4	EGI,#510001~	1N01-18-100
BVY12	HR15DE	1500	07.01~18.05	U13N04-COIL	4	EGI	1N08-18-100
BVZNY12	HR16DE	1600	07.01~18.05	U13N04-COIL	4	EGI	1N12-18-100

フレア

MJ34S	R06A	660	12.10~17.02	U19S01-COIL	3		1A13-18-100
MJ44S	R06A	660	15.09~17.02	U19S01-COIL	3		1A13-18-100
MJ55S	R06A	660	17.02~20.01	U22S02-COIL	3		1A17-18-100

フレアクロスオーバー

MS41S	R06A	660	14.01~20.01	U19S01-COIL	3		1A13-18-100
	R06A +WAO4A	660	15.05~20.01	U19S01-COIL	3		1A13-18-100

フレアワゴン

MM21S	K6A	660	12.06~13.02	U21S02-COIL (●U12S01-COIL)	3	TURBO,EPI	1A07-18-100A
MM32S	R06A	660	13.04~15.05	U19S01-COIL	3		1A13-18-100
MM42S	R06A	660	15.05~18.02	U19S01-COIL	3		1A13-18-100
MM53S	R06A	660	18.01~23.11	U22S02-COIL	3		1A17-18-100

フリーダ

SG5WF	J5	2500	95.06~01.08	U23M01-COIL	1		B6S7-18-100
SGE3F	FE	1998	97.11~01.04	U23M01-COIL	1		B6S7-18-100
SGEWF	FE	1998	95.07~01.08	U23M01-COIL	1		B6S7-18-100
SGL3F	WL	2499	95.06~00.05	U23M01-COIL	1		B6S7-18-100
SGL5F	WL	2499	95.06~01.04	U23M01-COIL	1		B6S7-18-100
SGLRF	WL	2499	95.06~01.06	U23M01-COIL	1		B6S7-18-100
SGLWF	WL	2499	95.06~00.08	U23M01-COIL	1		B6S7-18-100

プレマシー

CP8W	FPDE	1800	99.02~05.06	U15M02-COIL	2	EGI	FP85-18-100B
			03.04~05.02	U15M02-COIL	2	C,EGI	FP85-18-100C
CPEW	FSZE	2000	01.06~05.02	U15M02-COIL	2	EGI	FP85-18-100C
CR3W	L3VE	2300	05.02~09.04	U18M01-COIL	4	4AT	LF2L-18-100A
CREW	LFVD	2000	07.01~10.06	U18M01-COIL	4		LF2L-18-100A
	LFVE	2000	07.09~10.06	U18M01-COIL	4		LF2L-18-100A
CWEAW	LFVE	2000	10.05~	U18M01-COIL	4		LF2L-18-100A
CWEFW	LFVD	2000	10.07~14.08	U18M01-COIL	4		LF2L-18-100A
	LFVDS	2000	10.07~13.01	U18M01-COIL	4		LF2L-18-100A

プロシードレバンテ

TF11W	H20A	2000	95.02~96.09	U12S02-COIL	6	#150001~#200000	1A51-18-100
TF51W	J20A	2000	96.10~97.11	U12S02-COIL	4		1A51-18-100
TF52W	J20A	2000	97.11~99.09	U12S02-COIL	4	EPI	1A51-18-100A

●印：生産終了品

トヨタ TOYOTA
日産 NISSAN
ホンダ HONDA
マツダ MAZDA
スバル SUBARU
三菱 MITSUBISHI
スズキ SUZUKI
ダイハツ DAIHATSU
いすゞ ISUZU
対照表-1 純正品番
対照表-2 Astemo品番

マツダ

MAZDA

車両型式	エンジン型式	排気量	年式	Astemo品番	使用数	類別内容	適応純正品番(参考)
------	--------	-----	----	----------	-----	------	------------

プロシードレバンテ

TJ11W	H20A	2000	95.01~96.09	U12S02-COIL	6	#150001~#200000,AT	1A51-18-100
			95.02~96.09	U12S02-COIL	6	#150001~#200000,MT	1A51-18-100
TJ51W	J20A	2000	96.10~97.11	U12S02-COIL	4		1A51-18-100
TJ52W	J20A	2000	97.11~99.09	U12S02-COIL	4	EPI	1A51-18-100A
TJ61W	H25A	2500	96.10~97.11	U12S02-COIL	6		1A51-18-100
TJ62W	H25A	2500	98.02~99.09	U12S02-COIL	6	EPI	1A51-18-100

ベリーサ

DC5R	ZYVE	1500	04.06~05.05	U17M01-COIL	4	EPI	ZJ01-18-100
			04.06~15.03	U19M02-COIL	4	4WD	ZJ20-18-100A
DC5W	ZYVE	1500	04.06~05.05	U17M01-COIL	4	EPI,#100001-#200018	ZJ01-18-100
			04.06~15.12	U19M02-COIL	4		ZJ20-18-100A

ボンゴトラック

SK22L	R2	2184	99.05~03.11	U23M01-COIL	1		B6S7-18-100
SK22T	R2	2184	99.05~03.11	U23M01-COIL	1		B6S7-18-100
SK82L	F8-E	1789	99.05~07.07	U23M01-COIL	1		B6S7-18-100
SK82T	F8-E	1789	99.05~07.08	U23M01-COIL	1		B6S7-18-100
SKF2L	RF	1998	03.12~07.07	U23M01-COIL	1		B6S7-18-100
SKF2T	RF	1998	03.12~07.07	U23M01-COIL	1		B6S7-18-100
SKP2L	F8	1800	10.08~16.01	U22M01-COIL	4		LFB6-18-100C
SKP2T	F8	1800	10.08~16.01	U22M01-COIL	4		LFB6-18-100C
SLP2L	F8	1800	16.01~20.05	U22M01-COIL	4		LFB6-18-100C
SLP2T	F8	1800	16.01~20.05	U22M01-COIL	4		LFB6-18-100C

ボンゴバン

SK22M	R2	2184	99.07~03.11	U23M01-COIL	1		B6S7-18-100
SK22V	R2	2184	99.05~03.11	U23M01-COIL	1		B6S7-18-100
SK82M	F8-E	1789	99.05~07.07	U23M01-COIL	1		B6S7-18-100
SK82V	F8-E	1789	99.05~07.07	U23M01-COIL	1		B6S7-18-100
SKF2M	RF	1998	03.12~07.07	U23M01-COIL	1		B6S7-18-100
SKF2V	RF	1998	03.12~07.07	U23M01-COIL	1		B6S7-18-100
SKP2M	F8	1800	10.08~16.01	U22M01-COIL	4		LFB6-18-100C
SKP2V	F8	1800	10.08~16.01	U22M01-COIL	4		LFB6-18-100C
SLP2M	F8	1800	16.01~20.05	U22M01-COIL	4		LFB6-18-100C
SLP2V	F8	1800	16.01~20.05	U22M01-COIL	4		LFB6-18-100C

ボンゴフレンドィ

SG5W	J5	2500	95.04~02.08	U23M01-COIL	1		B6S7-18-100
SGE3	FE-E	1998	97.11~05.10	U23M01-COIL	1		B6S7-18-100
SGEW	FE	1998	95.05~05.12	U23M01-COIL	1		B6S7-18-100
SGL3	WL	2499	95.04~04.08	U23M01-COIL	1		B6S7-18-100
SGL5	WL	2499	95.04~04.08	U23M01-COIL	1		B6S7-18-100
SGLR	WL	2499	95.04~04.08	U23M01-COIL	1		B6S7-18-100
SGLW	WL	2499	95.05~04.08	U23M01-COIL	1		B6S7-18-100

ボンゴプロニートトラック

SD29M	R2	2184	97.04~99.05	U23M01-COIL	1		B6S7-18-100
SD29T	R2	2184	97.04~99.06	U23M01-COIL	1		B6S7-18-100
SD2AM	R2	2184	97.04~99.05	U23M01-COIL	1		B6S7-18-100
SD2AT	R2	2184	97.04~99.05	U23M01-COIL	1		B6S7-18-100
SD59M	WL	2499	97.04~99.05	U23M01-COIL	1		B6S7-18-100

西暦	1994	95	96	97	98	99	2000	01	02	03	04	05	06	07	08	09	10	11	12	13	14	15	16	17	18	19	20	21	22	23	24	25	26
和暦	平成6	7	8	9	10	11	12	13	14	15	16	17	18	19	20	21	22	23	24	25	26	27	28	29	30	令和元年	2	3	4	5	6	7	8

TOYOTA
トヨタ

NISSAN
日産

HONDA
ホンダ

MAZDA
マツダ

SUBARU
スバル

MITSUBISHI
三菱

SUZUKI
スズキ

DAIHATSU
ダイハツ

ISUZU
いすゞ

純正品番
対照表-1

Astemo品番
対照表-2

マツダ

MAZDA

車両型式	エンジン型式	排気量	年式	Astemo品番	使用数	類別内容	適応純正品番 (参考)
------	--------	-----	----	----------	-----	------	----------------

ボンゴブロニートラック

SD59T	WL	2499	97.04~99.05	U23M01-COIL	1		B6S7-18-100
SD5AM	WL	2499	97.04~99.05	U23M01-COIL	1		B6S7-18-100
SD5AT	WL	2499	97.04~99.05	U23M01-COIL	1		B6S7-18-100
SD89T	F8	1789	97.04~99.05	U23M01-COIL	1		B6S7-18-100
SDEAT	FE	1998	97.04~99.05	U23M01-COIL	1		B6S7-18-100
SK24L	R2	2184	99.06~00.08	U23M01-COIL	1		B6S7-18-100
SK24T	R2	2184	99.06~00.08	U23M01-COIL	1		B6S7-18-100
SK26L	R2	2184	99.06~00.08	U23M01-COIL	1		B6S7-18-100
SK26T	R2	2184	99.06~00.08	U23M01-COIL	1		B6S7-18-100
SK54L	WL	2499	99.06~00.08	U23M01-COIL	1		B6S7-18-100
SK54T	WL	2499	99.06~00.08	U23M01-COIL	1		B6S7-18-100
SK56L	WL	2499	99.06~00.08	U23M01-COIL	1		B6S7-18-100
SK56T	WL	2499	99.06~00.09	U23M01-COIL	1		B6S7-18-100
SKE4T	FE-E	1998	99.06~00.08	U23M01-COIL	1		B6S7-18-100
SKE6T	FE-E	1998	99.06~00.08	U23M01-COIL	1		B6S7-18-100

ボンゴブロニーバン

SK54V	WL	2499	99.06~04.01	U23M01-COIL	1		B6S7-18-100
SK56M	WL	2499	99.06~04.01	U23M01-COIL	1		B6S7-18-100
SK56V	WL	2499	99.06~04.01	U23M01-COIL	1		B6S7-18-100
SK5HM	WL	2499	99.06~04.01	U23M01-COIL	1		B6S7-18-100
SK5HV	WL	2499	99.06~03.11	U23M01-COIL	1		B6S7-18-100
SKE6V	FE-E	1998	99.06~07.07	U23M01-COIL	1		B6S7-18-100
SKF6M	RF	1998	04.02~07.07	U23M01-COIL	1		B6S7-18-100
SKF6V	RF	1998	04.02~07.07	U23M01-COIL	1		B6S7-18-100
SKFHM	RF	1998	04.02~07.05	U23M01-COIL	1		B6S7-18-100
SKFHV	RF	1998	04.02~07.07	U23M01-COIL	1		B6S7-18-100
SR59V	WL	2499	97.04~99.05	U23M01-COIL	1		B6S7-18-100
SR5AM	WL	2499	97.04~99.05	U23M01-COIL	1		B6S7-18-100
SR5AV	WL	2499	97.04~99.05	U23M01-COIL	1		B6S7-18-100
SREAV	FE	1998	97.04~99.05	U23M01-COIL	1		B6S7-18-100

ラピュタ

HP11S	F6A	660	99.03~01.04	U21S02-COIL ●U12S01-COIL	3	mitsubishi(7-7DE)TURBO	1A09-18-100
HP12S	K6A	660	01.04~01.11	U21S02-COIL ●U12S01-COIL	3	mitsubishi(7-7DE)TURBO	1A09-18-100
HP21S	K6A	660	99.03~99.10	U21S02-COIL ●U12S01-COIL	3	TURBO,EPI	1A05-18-100
HP22S	K6A	660	01.04~05.12	U21S02-COIL ●U12S01-COIL	3	TURBO,EPI	1A05-18-100A

ロードスター

NCEC	LFVE	2000	05.08~15.01	U18M03-COIL	4	EGI	L3G2-18-100A
------	------	------	-------------	-------------	---	-----	--------------

●印：生産終了品

スバル

SUBARU

車両型式	エンジン 型式	排気量	年 式	Astemo品番	使用数	類 別 内 容	適応純正品番 (参考)
------	------------	-----	-----	----------	-----	---------	----------------

BRZ

ZC6	FA20C	2000	16.04~	U23T07-COIL	4		22433AA730
	FA20D	2000	11.11~	U23T07-COIL	4		22433AA730

R1

RJ1	EN07	660	04.11~10.04	U15F04-COIL	4	R,EGI,CVT	22433KA611
-----	------	-----	-------------	-------------	---	-----------	------------

R2

RC1	EN07	660	03.10~10.04	U15F04-COIL	4	R,EGI	22433KA610
RC2	EN07	660	03.10~10.04	U15F04-COIL	4	R,EGI	22433KA610
RJ2	EN07	660	04.11~10.04	U15F04-COIL	4	R,EGI,CVT	22433KA611

WRX

GRB	EJ20	2000	09.07~14.04	U18F03-COIL	4	TURBO	22433AA640
GRF	EJ25	2500	09.07~14.04	U18F03-COIL	4	TURBO	22433AA640
GVB	EJ20	2000	09.07~14.04	U18F03-COIL	4	TURBO	22433AA640
GVF	EJ25	2500	09.07~14.04	U18F03-COIL	4	TURBO	22433AA640
VAB	EJ20	2000	14.02~	U18F03-COIL	4	TURBO	22433AA641
VAG	FA20	2000	14.02~	U19F01-COIL	4	TURBO	22433AA700

XV

GT3	FB16	1600	17.03~	U20F01-COIL	4	4WD	22433AA741
GT7	FB20	2000	17.03~19.11	U20F01-COIL	4	4WD	22433AA741
GTE	FB20 +MA1	2000	18.08~	U20F02-COIL	4	4WD	22433AA781

YRV

BD5	EJ20	2000	95.12~98.11	U18F02-COIL	4		22433AA561
BE5	EJ20	2000	98.08~01.04	U18F02-COIL	4		22433AA561
BG5	EJ20	2000	95.12~98.10	U18F02-COIL	4		22433AA561
BH5	EJ20	2000	97.11~01.04	U18F02-COIL	4		22433AA561

インプレッサ

GC8	EJ20	2000	98.09~00.07	U13F03-COIL	1	TURBO,S201,WRX,WRX RA, WRX RA STI,WRX STI	22433AA430
			98.04~00.07	U18F02-COIL	4	SRX	22433AA561
GD9	EJ20	2000	00.02~01.08	U18F02-COIL	4	EGI	22433AA561
			01.06~03.07	U13F01-COIL	4	EGI	22433AA451
GDA	EJ20	2000	00.02~02.10	U18F02-COIL	4	TURBO	22433AA561
			02.09~07.06	U13F01-COIL	4	TURBO	22433AA451
GDB	EJ20	2000	00.02~02.10	U18F02-COIL	4	TURBO	22433AA561
			02.09~07.06	U13F01-COIL	4	TURBO	22433AA451
GDC	EL15	1500	06.04~	U18F03-COIL	4	EGI	22433AA480
GDD	EL15	1500	06.04~	U18F03-COIL	4	EGI	22433AA480
GE2	EL15	1500	08.07~10.06	U18F03-COIL	4	EGI	22433AA540
GE3	EL15	1500	08.07~10.06	U18F03-COIL	4	EGI	22433AA540
GF8	EJ20	2000	98.04~00.07	U18F02-COIL	4	TURBO,SRX	22433AA561
			98.09~00.07	U13F03-COIL	1	TURBO,WRX	22433AA430
GG9	EJ20	2000	00.02~01.08	U18F02-COIL	4	EGI	22433AA561
			01.06~04.05	U13F01-COIL	4	EGI	22433AA451
GGA	EJ20	2000	00.02~02.10	U18F02-COIL	4	TURBO	22433AA561
			02.09~07.06	U13F01-COIL	4	TURBO,WRX	22433AA451

西暦	1994	95	96	97	98	99	2000	01	02	03	04	05	06	07	08	09	10	11	12	13	14	15	16	17	18	19	20	21	22	23	24	25	26
和暦	平成6	7	8	9	10	11	12	13	14	15	16	17	18	19	20	21	22	23	24	25	26	27	28	29	30	令和元年	2	3	4	5	6	7	8

TOYOTA
トヨタ

NISSAN
日産

HONDA
ホンダ

MAZDA
マツダ

SUBARU
スバル

MITSUBISHI
三菱

SUZUKI
スズキ

DAIHATSU
ダイハツ

ISUZU
いすゞ

純正品番順
対照表-1

Astemo品番順
対照表-2

スバル

SUBARU

車両型式	エンジン型式	排気量	年式	Astemo品番	使用数	類別内容	適応純正品番(参考)
------	--------	-----	----	----------	-----	------	------------

インプレッサ

GGB	EJ20	2000	00.02~02.10	U18F02-COIL	4		22433AA561
GGC	EL15	1500	06.04~	U18F03-COIL	4	EGI	22433AA480
GGD	EL15	1500	06.04~	U18F03-COIL	4	EGI	22433AA480
GH2	EL15	1500	07.03~10.06	U18F03-COIL	4	EGI	22433AA480
			10.04~11.11	U18F03-COIL	4	EGI	22433AA640
GH3	EL15	1500	07.03~10.06	U18F03-COIL	4	EGI	22433AA480
			10.04~11.11	U18F03-COIL	4	EGI	22433AA640
GH6	EJ20	2000	08.07~11.11	U15F01-COIL	1	EGI	22433AA580
GH7	EJ20	2000	07.03~11.11	U15F01-COIL	1	EGI	22433AA500
GH8	EJ20	2000	07.03~10.05	U18F03-COIL	4	TURBO	22433AA480
			10.04~11.11	U20F03-COIL	4	TURBO,4WD	22433AA602
GK2	FB16	1600	16.08~	U20F01-COIL	4	2WD	22433AA741
GK3	FB16	1600	16.08~	U20F01-COIL	4	4WD	22433AA741
GK6	FB20	2000	16.08~	U20F01-COIL	4	2WD	22433AA741
GK7	FB20	2000	16.08~	U20F01-COIL	4	4WD	22433AA741
GRB	EJ20	2000	07.03~10.06	U18F03-COIL	4	TURBO	22433AA540
						TURBO,WRX	22433AA640
GRF	EJ25	2500	08.07~10.06	U18F03-COIL	4	TURBO	22433AA540
						TURBO,WRX	22433AA640
GJ2	FB16	1600	12.02~12.12	U20F04-COIL	4		22433AA682
			11.09~16.08	U22F01-COIL	4		22433AA630
GJ3	FB16	1600	12.02~12.12	U20F04-COIL	4	4WD	22433AA682
			11.09~16.09	U22F01-COIL	4		22433AA630
GJ6	FB20	2000	12.02~12.12	U20F04-COIL	4		22433AA682
			11.09~16.09	U22F01-COIL	4		22433AA630
GJ7	FB20	2000	12.02~12.12	U20F04-COIL	4	4WD	22433AA682
			11.09~16.09	U22F01-COIL	4		22433AA630
GP2	FB16	1600	12.07~16.09	U20F04-COIL	4	特記事項:純正品番を照合ください	22433AA682
			11.09~12.09	U22F01-COIL	4	特記事項:純正品番を照合ください	22433AA630
GP3	FB16	1600	12.02~12.12	U20F04-COIL	4	4WD	22433AA682
			11.09~16.09	U22F01-COIL	4		22433AA630
GP6	FB20	2000	12.02~12.12	U20F04-COIL	4		22433AA682
			11.09~16.05	U22F01-COIL	4		22433AA630
GP7	FB20	2000	12.02~12.12	U20F04-COIL	4	4WD	22433AA682
			11.09~16.09	U22F01-COIL	4		22433AA630
GT2	FB16	1600	16.08~	U20F01-COIL	4	2WD	22433AA741
GT3	FB16	1600	16.08~	U20F01-COIL	4	4WD	22433AA741
GT6	FB20	2000	16.08~	U20F01-COIL	4	2WD	22433AA741
GT7	FB20	2000	16.08~	U20F01-COIL	4	4WD	22433AA741
GPE	FB20	2000	14.10~	U23T07-COIL	4		22433AA730

インプレッサ XV

GH2	EL15	1500	10.04~11.11	U18F03-COIL	4	EGI	22433AA640
GH3	EL15	1500	10.04~11.11	U18F03-COIL	4	EGI	22433AA640
GH7	EJ20	2000	10.04~11.11	U15F01-COIL	1	EGI	22433AA500
GP7	FB20	2000	12.02~12.12	U20F04-COIL	4	4WD	22433AA682
GPE	FB20	2000	13.03~17.03	U23T07-COIL	4		22433AA730

インプレッサ アネシス

GE2	EL15	1500	10.04~11.11	U18F03-COIL	4	EGI	22433AA640
GE3	EL15	1500	10.04~11.11	U18F03-COIL	4	EGI	22433AA640
GE6	EJ20	2000	08.07~11.11	U15F01-COIL	1	EGI	22433AA580
GE7	EJ20	2000	08.07~11.11	U15F01-COIL	1	EGI	22433AA580

●印:生産終了品

トヨタ TOYOTA
日産 NISSAN
ホンダ HONDA
マツダ MAZDA
スバル SUBARU
三菱 MITSUBISHI
スズキ SUZUKI
ダイハツ DAIHATSU
いすゞ ISUZU
対照表-1 純正品番
対照表-2 Astemo品番

スバル

SUBARU

車両型式	エンジン型式	排気量	年式	Astemo品番	使用数	類別内容	適応純正品番(参考)
------	--------	-----	----	----------	-----	------	------------

エクシーガ

YA4	EJ20	2000	08.04~12.06	U18F03-COIL	4	EGI	22433AA540
YA5	EJ20	2000	08.04~15.04	U18F03-COIL	4	EGI,TURBO	22433AA540
YA9	EJ25	2500	09.07~12.06	U19F03-COIL	4	4WD	22433AA621
YAM	FB25	2500	12.05~12.12	U20F04-COIL	4	4WD	22433AA682

サンバー

KS3	EN07	660	95.10~98.12	U12F01-COIL	1	CVT,加 ^レ - ^レ ASSY,MPI	22433KA470
					2	CVT,加 ^レ - ^レ ASSY	22433KA470
KS4	EN07	660	95.10~98.12	U12F01-COIL	2	5MT,加 ^レ - ^レ ASSY	22433KA470
			97.10~98.12	U12F01-COIL	1	3AT,加 ^レ - ^レ ASSY	22433KA470
KV3	EN07	660	95.10~98.12	U12F01-COIL	1	CVT,加 ^レ - ^レ ASSY,MPI	22433KA470
					2	MT,加 ^レ - ^レ ASSY	22433KA470
KV4	EN07	660	95.10~98.12	U12F01-COIL	1	3AT,加 ^レ - ^レ ASSY,MPI	22433KA470
					2	5MT,加 ^レ - ^レ ASSY	22433KA470
S201H	KFVE	660	12.04~14.07	U18D04-COIL	2	5MT,加 ^レ - ^レ ASSY,MPI	22433KA470
					2	CVT,加 ^レ - ^レ ASSY	22433KA470
S201J	KFVE	660	12.04~14.07	U18D04-COIL	3	EGI	19500-B2050
S211H	KFVE	660	12.04~14.07	U18D04-COIL	3	EGI	19500-B2050
S211J	KFVE	660	12.04~14.07	U18D04-COIL	3	EGI	19500-B2050
S321B	KFDET	660	12.04~	U18D04-COIL	3	TURBO	19500-B2050
	KFVE	660	12.04~	U18D04-COIL	3	EGI	19500-B2050
S321Q	KFVE	660	12.04~	U18D04-COIL	3	EGI	19500-B2050
S331B	KFDET	660	12.04~	U18D04-COIL	3	TURBO	19500-B2050
	KFVE	660	12.04~	U18D04-COIL	3	EGI	19500-B2050
S331Q	KFVE	660	12.04~19.11	U18D04-COIL	3	EGI	19500-B2050
S500J	KFVE	660	14.08~18.05	U18D04-COIL	3	EGI	19500-B2050
	KF	660	18.05~	U18D04-COIL	3		19500-B2050
S510J	KFVE	660	14.08~18.05	U18D04-COIL	3	EGI	19500-B2050
	KF	660	18.05~	U18D04-COIL	3		19500-B2051
TT1	EN07	660	98.08~00.04	U13F02-COIL	1	5MT,EGI	22433KA581
			98.08~12.04	U13F02-COIL	1	EGI,LPG	22433KA581
TT2	EN07	660	98.08~12.04	U13F02-COIL	1		22433KA581
TV1	EN07	660	98.08~12.04	U13F02-COIL	1		22433KA581
TV2	EN07	660	98.10~12.04	U13F02-COIL	1		22433KA581

サンバー ディアス

KV3	EN07	660	95.10~98.12	U12F01-COIL	2	5MT,加 ^レ - ^レ ASSY	22433KA470
				U12F01-COIL	1	5MT,加 ^レ - ^レ ASSY,MPI	22433KA470
KV4	EN07	660	95.10~98.12	U12F01-COIL	1	5MT,加 ^レ - ^レ ASSY,MPI	22433KA470
				U12F01-COIL	2	CVT,加 ^レ - ^レ ASSY	22433KA470
TV1	EN07	660	98.08~12.04	U13F02-COIL	1		22433KA581
TV2	EN07	660	98.08~12.04	U13F02-COIL	1		22433KA581
TW1	EN07	660	99.05~09.08	U13F02-COIL	1		22433KA581
TW2	EN07	660	99.07~09.08	U13F02-COIL	1		22433KA581

ステラ

LA100F	KFDET	660	11.08~14.11	U18D04-COIL	3	TURBO	19500-B2050
	KFVE	660	11.04~14.11	U18D04-COIL	3	EGI	19500-B2050
LA110F	KFDET	660	11.08~14.11	U18D04-COIL	3	TURBO	19500-B2050
	KFVE	660	11.04~14.11	U18D04-COIL	3	EGI	19500-B2050

西暦	1994	95	96	97	98	99	2000	01	02	03	04	05	06	07	08	09	10	11	12	13	14	15	16	17	18	19	20	21	22	23	24	25	26
和暦	平成6	7	8	9	10	11	12	13	14	15	16	17	18	19	20	21	22	23	24	25	26	27	28	29	30	令和元年	2	3	4	5	6	7	8

TOYOTA
トヨタ

NISSAN
日産

HONDA
ホンダ

MAZDA
マツダ

SUBARU
スバル

mitsubishi
三菱

SUZUKI
スズキ

DAIHATSU
ダイハツ

ISUZU
いすゞ

純正品番
対照表-1

Astemo品番
対照表-2

スバル

SUBARU

車両型式	エンジン型式	排気量	年式	Astemo品番	使用数	類別内容	適応純正品番(参考)
------	--------	-----	----	----------	-----	------	------------

ステラ

LA150F	KFVET	660	14.11~20.08	U18D04-COIL	3	TURBO	19500-B2050
	KFVE	660	14.11~	U18D04-COIL	3	EGI	19500-B2050
LA160F	KFVET	660	14.11~20.08	U18D04-COIL	3	TURBO	19500-B2050
	KFVE	660	14.11~	U18D04-COIL	3	EGI	19500-B2050
RN1	EN07	660	06.04~11.04	U15F04-COIL	4	EGI	22433KA612
RN2	EN07	660	06.04~11.04	U15F04-COIL	4	EGI	22433KA612

ディアス

S321N	KFDET	660	09.08~15.03	U17D01-COIL	3	TURBO	19500-B2030
			09.08~19.11	U18D04-COIL	3	TURBO	19500-B2050
S331N	KFDET	660	09.08~15.03	U17D01-COIL	3	TURBO	19500-B2030
			09.08~19.11	U18D04-COIL	3	TURBO	19500-B2050

トレジア

NCP120X	1NZFE	1500	10.11~16.07	U13T04-COIL	4	EGI	90919-02260
NCP125X	1NZFE	1500	10.11~16.07	U13T04-COIL	4	EGI	90919-02260

フォレスター

SF5	EJ20	2000	98.08~02.01	U13F03-COIL	1	TURBO	22433AA430
SG5	EJ20	2000	04.11~07.12	U15F01-COIL	1	EGI	22433AA500
			01.11~07.12	U13F01-COIL	4	TURBO	22433AA451
SG9	EJ25	2500	03.11~	U18F03-COIL	4	TURBO	22433AA480
SH5	EJ20	2000	07.09~10.04	U18F03-COIL	4	EGI	22433AA540
				U18F03-COIL	4	TURBO	22433AA540
			10.04~10.09	U18F03-COIL	4	EGI	22433AA640
			10.04~12.06	U18F03-COIL	4	TURBO	22433AA640
SH9	EJ25	2500	10.07~12.11	U18F03-COIL	4	TURBO	22433AA640
SHJ	FB20	2000	10.07~11.11	U22F01-COIL	4		22433AA630
SJ5	FB20	2000	12.08~	U20F04-COIL	4	4WD	22433AA682
			12.08~	U19F01-COIL	4		22433AA700
SJG	FA20	2000	12.08~	U19F01-COIL	4		22433AA700
SK5	CB18	1800	20.09~	U21F01-COIL	4	4WD	22433AA800
SKE	FB20+MA1	2000	18.05~	U20F02-COIL	4	4WD	22433AA781
SLG	FB25	2500	25.01~	U20F02-COIL	4		22433AA840

プレオ

L275B	KFVE	660	10.04~18.01	U18D04-COIL	3	EGI	19500-B2050
L275F	KFDET	660	10.04~11.07	U18D04-COIL	3	TURBO	19500-B2050
	KFVE	660	10.04~18.01	U18D04-COIL	3	EGI	19500-B2050
L285B	KFVE	660	10.04~18.01	U18D04-COIL	3	EGI	19500-B2050
L285F	KFDET	660	10.04~11.07	U18D04-COIL	3	TURBO	19500-B2050
	KFVE	660	10.04~18.01	U18D04-COIL	3	EGI	19500-B2050

プレオ プラス

LA300F	KFVE	660	12.12~17.04	U18D04-COIL	3	EGI	19500-B2050
LA310F	KFVE	660	12.12~17.04	U18D04-COIL	3	EGI	19500-B2050

●印：生産終了品

トヨタ TOYOTA
日産 NISSAN
ホンダ HONDA
マツダ MAZDA
スバル SUBARU
三菱 MITSUBISHI
スズキ SUZUKI
ダイハツ DAIHATSU
いすゞ ISUZU
対照表-1 純正品番順
対照表-2 Astemo品番順

スバル

SUBARU

車両型式	エンジン型式	排気量	年式	Astemo品番	使用数	類別内容	適応純正品番(参考)
------	--------	-----	----	----------	-----	------	------------

ルクラ

L455F	KFDET	660	10.04~14.09	U18D04-COIL	3	TURBO	19500-B2050
	KFVE	660	10.04~14.09	U18D04-COIL	3	EGI	19500-B2050
L465F	KFDET	660	10.04~14.09	U18D04-COIL	3	TURBO	19500-B2050
	KFVE	660	10.04~14.09	U18D04-COIL	3	EGI	19500-B2050

レヴォーグ

VM4	FB16	1600	14.02~	U19F01-COIL	4		22433AA700
VMG	FA20	2000	14.02~	U19F01-COIL	4		22433AA700
VN5	CB18	1800	20.10~	U21F01-COIL	4	4WD	22433AA800

レオーネバン(ADバン)

CVFY11	QG15DE	1500	00.01~04.05	U08001-COIL	4	リ-ゾ-ン仕様	22448-4M50A
				U08101-COIL	4	除く(リ-ゾ-ン仕様)	22448-6N015
CVHNY11	QG18DE	1800	00.01~04.05	U08001-COIL	4	リ-ゾ-ン仕様	22448-4M50A
				U08101-COIL	4	除く(リ-ゾ-ン仕様)	22448-6N015

レガシィ

BH5	EJ20	2000	00.05~03.04	U13F01-COIL	4	TURBO	22433AA451
			01.05~03.04	U13F01-COIL	4	EGI	22433AA451
BH9	EJ25	2500	01.05~03.04	U13F01-COIL	4	EGI	22433AA451
BL5	EJ20	2000	03.01~09.04	U18F03-COIL	4	TURBO	22433AA480
				U18F03-COIL	4	EGI,B4 2.0R,含む(B-Spec)	22433AA480
BL9	EJ25	2500	08.03~09.04	U18F03-COIL	4	TURBO	22433AA540
BN9	FB25	2500	14.07~	U19F01-COIL	4		22433AA700
BP5	EJ20	2000	03.01~07.08	U15F01-COIL	1	4AT,2.0i,EGI	22433AA500
			07.08~09.04	U15F01-COIL	1	5MT,2.0i,EGI	22433AA500
BP5	EJ20	2000	03.01~09.04	U18F03-COIL	4	TURBO	22433AA480
				U18F03-COIL	4	EGI,2.0R,含む(B-Spec)	22433AA480
BP9	EJ25	2500	07.08~09.04	U15F01-COIL	1	EGI	22433AA580
			08.03~09.04	U18F03-COIL	4	TURBO	22433AA540
BM9	EJ25	2500	09.02~12.04	U19F03-COIL	4	4WD,25i series	22433AA621
			09.02~14.09	U20F03-COIL	4	4WD,25GT series	22433AA602
BR9	EJ25	2500	09.02~12.04	U19F03-COIL	4	4WD,25i series	22433AA621
			09.02~13.04	U20F03-COIL	4	4WD,25GT series	22433AA602
BMM	FB25	2500	12.02~12.12	U20F04-COIL	4	4WD,B4	22433AA682
BRM	FB25	2500	12.02~	U20F04-COIL	4	4WD	22433AA682

レガシィ B4

BE5	EJ20	2000	00.05~03.04	U13F01-COIL	4	RSK,TURBO	22433AA451
			01.05~03.04	U13F01-COIL	4	EGI	22433AA451
BE9	EJ25	2500	01.05~03.04	U13F01-COIL	4	EGI	22433AA451
BES	EJ20	2000	02.11~03.04	U13F01-COIL	4	TURBO	22433AA451
BL5	EJ20	2000	03.01~07.08	U15F01-COIL	1	2.0i,EGI,4AT	22433AA580
			07.08~09.04	U15F01-COIL	1	2.0i,EGI,5MT	22433AA580
BL9	EJ25	2500	07.08~09.04	U15F01-COIL	4	2.5i ア-バ-リカクヨンEGI,4AT	22433AA580

レガシィ アウトバック

BP9	EJ25	2500	03.01~09.04	U15F01-COIL	1	EGI	22433AA500
BPH	EJ25	2500	08.03~09.04	U18F03-COIL	4	TURBO	22433AA540
BS9	FB25	2500	14.07~	U19F01-COIL	4		22433AA700
BR9	EJ25	2500	09.02~12.04	U19F03-COIL	4	4WD	22433AA621
BRM	FB25	2500	12.02~	U20F04-COIL	4	4WD	22433AA682

西暦	1994	95	96	97	98	99	2000	01	02	03	04	05	06	07	08	09	10	11	12	13	14	15	16	17	18	19	20	21	22	23	24	25	26
和暦	平成6	7	8	9	10	11	12	13	14	15	16	17	18	19	20	21	22	23	24	25	26	27	28	29	30	令和元年	2	3	4	5	6	7	8

TOYOTA
トヨタ

NISSAN
日産

HONDA
ホンダ

MAZDA
マツダ

SUBARU
スバル

MAZDA
マツダ

SUZUKI
スズキ

DAIHATSU
ダイハツ

ISUZU
いすゞ

純正品番
対照表-1

Astemo品番
対照表-2

スバル

SUBARU

車両型式	エンジン 型式	排気量	年 式	Astemo品番	使用数	類 別 内 容	適応純正品番 (参考)
------	------------	-----	-----	----------	-----	---------	----------------

レガシィ ランカスター

BH9	EJ25	2500	01.05~03.04	U13F01-COIL	4	EGI	22433AA451
-----	------	------	-------------	-------------	---	-----	------------

トヨタ
TOYOTA

日産
NISSAN

ホンダ
HONDA

マツダ
MAZDA

スバル
SUBARU

三菱
MITSUBISHI

スズキ
SUZUKI

ダイハツ
DAIHATSU

いすゞ
ISUZU

対照表-1
純正品番順

対照表-2
Astemo品番順

●印：生産終了品

車両型式	エンジン型式	排気量	年式	Astemo品番	使用数	類別内容	適応純正品番(参考)
------	--------	-----	----	----------	-----	------	------------

eK アクティブ

H81W	3G83	660	04.05~06.08	U11C01-COIL	3	ECI	MD346383
------	------	-----	-------------	-------------	---	-----	----------

eK カスタム

B11W	3B20	660	13.05~19.01	U19N02-COIL	3		1832A057
------	------	-----	-------------	-------------	---	--	----------

eK クラッシィ

H81W	3G83	660	03.05~05.11	U11C01-COIL	3		MD346383
------	------	-----	-------------	-------------	---	--	----------

eK スペース

B11A	3B20	660	14.01~20.01	U19N02-COIL	3		1832A057
------	------	-----	-------------	-------------	---	--	----------

eK スポーツ

H82W	3G83	660	06.08~12.06	U11C01-COIL	3	TURBO	MD346383
------	------	-----	-------------	-------------	---	-------	----------

eK ワゴン

B11W	3B20	660	13.05~19.01	U19N02-COIL	3		1832A057
H81W	3G83	660	01.09~06.08	U11C01-COIL	3	ECI	MD346383
H82W	3G83	660	06.08~12.06	U11C01-COIL	3	ECI	MD346383
			12.06~13.04	U21C01-COIL	3		1832A059

FTO

DE2A	4G93	1800	94.09~95.09	U15C03-COIL	2	ECI	MD314583
			95.10~00.08	U11C02-COIL	2	ECI	MD325048

i(アイ)

HA1W	3B20	660	05.12~13.04	U20C02-COIL	3		1832A028
------	------	-----	-------------	-------------	---	--	----------

RVR

GA3W	4B10	1800	10.02~12.09	U18C02-COIL	4		1832A016
GA4W	4J10	1800	11.10~19.07	U18C02-COIL	4		1832A016
N61W	4G93	1800	97.09~02.08	U11C03-COIL	4	GDI	MD354007
N71W	4G93	1800	97.09~02.08	U11C03-COIL	4	GDI	MD354007
N73WG	4G63	2000	97.09~02.08	U12C03-COIL	2	TURBO	MD321461

アウトランダー/アウトランダー(PHEV)

CW4W	4B11	2000	09.12~12.09	U18C02-COIL	4		1832A016
CW5W	4B12	2400	05.09~12.09	U18C02-COIL	4		1832A016
CW6W	6B31	3000	07.09~09.07	U18C02-COIL	6	4WD	1832A016
GF7W	4J11	2000	12.12~16.12	U21C03-COIL	4		1832A062
GF8W	4J12	2400	12.12~16.12	U21C03-COIL	4	4WD	1832A062
GG2W	4B11	2000	12.12~16.12	U21C03-COIL	4		1832A062

アスパイア

EA1A	4G93	1800	98.08~00.04	U11C03-COIL	4	GDI	MD354007
EA7A	4G94	2000	00.05~02.12	U11C03-COIL	4	GDI	MD366821
EC1A	4G93	1800	99.06~00.04	U11C03-COIL	4	GDI	MD354007
EC7A	4G94	2000	00.05~02.12	U11C03-COIL	4	GDI	MD362913

西暦	1994	95	96	97	98	99	2000	01	02	03	04	05	06	07	08	09	10	11	12	13	14	15	16	17	18	19	20	21	22	23	24	25	26
和暦	平成6	7	8	9	10	11	12	13	14	15	16	17	18	19	20	21	22	23	24	25	26	27	28	29	30	令和元年	2	3	4	5	6	7	8

TOYOTA
トヨタ

NISSAN
日産

HONDA
ホンダ

MAZDA
マツダ

SUBARU
スバル

MITSUBISHI
三菱

SUZUKI
スズキ

DAIHATSU
ダイハツ

ISUZU
いすゞ

純正品番
対照表-1

Astemo品番
対照表-2

三菱

MITSUBISHI

車両型式	エンジン型式	排気量	年式	Astemo品番	使用数	類別内容	適応純正品番(参考)
------	--------	-----	----	----------	-----	------	------------

エアトレック

CU2W	4G63	2000	01.03~05.09	U11C02-COIL	2	SOHC,ECl,TURBO	MD362907
				U12C03-COIL	2	DOHC,ECl,TURBO	MD363552
CU4W	4G64	2400	02.12~03.12	U11C02-COIL	2	SOHC 除く(TURBO,ECl)	MD362907

カリスマ

DA2A	4G93(GDI)	1800	96.10~97.04	U11C02-COIL	2		MD325048
	4G93	1800	97.05~98.12	U11C03-COIL	4		MD366821

キャンター

FB700A	4G63	2000	03.07~10.11	U15C03-COIL	2	MPI	MD314583
FB700B	4G63	2000	03.07~10.11	U15C03-COIL	2	MPI	MD314583

ギャラン

EA1A	4G93	1800	97.06~00.04	U11C03-COIL	4	GDI	MD346866
EA7A	4G94	2000	00.05~05.11	U11C03-COIL	4	GDI	MD362913
EC1A	4G93	1800	97.09~00.04	U11C03-COIL	4	GDI	MD346866
EC7A	4G94	2000	00.05~05.11	U11C03-COIL	4		MD366821

ギャランフォルティス

CY3A	4B10	1800	09.12~11.09	U18C02-COIL	4		1832A016
CY4A	4B11	2000	07.08~09.11	U18C02-COIL	4		1832A016
CY6A	4J10	1800	11.10~15.03	U18C02-COIL	4		1832A016
CX3A	4B10	1800	09.12~11.09	U18C02-COIL	4		1832A016
CX4A	4B11	2000	08.11~09.11	U18C02-COIL	4		1832A016
CX6A	4J10	1800	11.10~15.03	U18C02-COIL	4		1832A016

コルト

Z21A	4A90	1300	04.09~10.04	U21C02-COIL	3		MN195616
Z22A	4A90	1300	04.09~10.04	U21C02-COIL	3	4WD	MN195616
Z23A	4A91	1500	04.09~10.04	U21C02-COIL	3		MN195616
Z24A	4A91	1500	04.09~08.09	U21C02-COIL	3	4WD	MN195616

コルトプラス

Z23W	4A91	1500	04.08~10.04	U21C02-COIL	3		MN195616
Z24W	4A91	1500	04.08~10.04	U21C02-COIL	3		MN195616

シャリオ グランディス

N86W	6G72	3000	99.08~02.04	U11C03-COIL	6	GDI	MD366821
N96W	6G72	3000	99.08~02.04	U11C03-COIL	6	GDI	MD366821

タウンボックス

U61W	3G83	660	98.11~11.10	U11C01-COIL	3	ECl,TURBO	MD346383
U62W	3G83	660	98.11~11.10	U11C01-COIL	3	ECl,TURBO	MD346383
U63W	4A30	660	98.11~02.08	U13C01-COIL	2	TURBO	MD338017
U64W	4A30	660	98.11~02.08	U13C01-COIL	2	TURBO	MD338017

トヨタ
TOYOTA

日産
NISSAN

ホンダ
HONDA

マツダ
MAZDA

スバル
SUBARU

三菱
MITSUBISHI

スズキ
SUZUKI

ダイハツ
DAIHATSU

いすゞ
ISUZU

対照表-1
純正品番順

対照表-2
Astemo品番順

●印：生産終了品

車両型式	エンジン型式	排気量	年式	Astemo品番	使用数	類別内容	適応純正品番(参考)
------	--------	-----	----	----------	-----	------	------------

タウンボックス ワイド

U65W	4A31	1100	99.04~01.05	U12C04-COIL	2	mitsubishi,ECI	MD308914
				U15C01-COIL	2	DENSO,ECI	MD325592
U66W	4A31	1100	99.04~01.05	U12C04-COIL	2	mitsubishi,ECI	MD308914
				U15C01-COIL	2	DENSO,ECI	MD325592

タウンボックス ワゴン

U62W	3G83	660	02.09~04.10	U11C01-COIL	3		MD346383
------	------	-----	-------------	-------------	---	--	----------

チャレンジャー

K96W	6G72	3000	96.05~98.07	U15C03-COIL	3	NO.2,ECI	MD314583
------	------	------	-------------	-------------	---	----------	----------

ディアマンテ

F31A	6G73	2500	99.09~02.08	U11C03-COIL	6	除く(DOHC,ECI)	MD362913
F36A	6G72	3000	97.07~02.08	U11C03-COIL	6	GDI	MD346866
F41A	6G73	2500	99.09~02.08	U11C03-COIL	6	除く(DOHC,ECI)	MD362913
F46A	6G72	3000	97.07~02.08	U11C03-COIL	6	GDI	MD346866

ディオ

CR5W	4G93	1800	02.04~05.12	U11C03-COIL	4	TURBO	MD366821
CR6W	4G94	2000	00.07~05.12	U11C03-COIL	4	GDI	MD366821

デリカ D:2

MB15S	K12B	1200	11.03~15.10	U15S02-COIL	4		MQ500763
			13.12~15.07	U22S01-COIL	4		MQ509900

デリカ D:3

BM20	HR16DE	1600	11.09~	U13N04-COIL	4		MQ701134
BVM20	HR16DE	1600	11.09~	U13N04-COIL	4		MQ701134

デリカ D:5

CV2W	4J11	2000	11.12~19.12	U18C02-COIL	4		1832A016
CV4W	4B11	2000	09.12~11.11	U18C02-COIL	4		1832A016
CV5W	4B12	2400	06.12~19.12	U18C02-COIL	4		1832A016

デリカトラック

SKP2LM	L8	1800	10.09~11.10	U22M01-COIL	4		MQ913543
SKP2MM	L8	1800	10.09~11.10	U22M01-COIL	4		MQ913543
SKP2TM	L8	1800	10.09~11.10	U22M01-COIL	4		MQ913543
SKP2VM	L8	1800	10.09~11.10	U22M01-COIL	4		MQ913543

トッポ

H82A	3G83	660	08.09~12.06	U11C01-COIL	3	ECI,TURBO	MD346383
			12.06~13.04	U21C01-COIL	3		1832A059

トッポ BJ

H41A	4A30	660	99.12~02.07	U13C01-COIL	2	R,TURBO	MD338017
			99.09~01.11	U12C04-COIL	2	MT,SOHC,mitsubishi,TURBO	MD308914
			99.09~02.07	U15C01-COIL	2	MT,SOHC,DENSO,TURBO	MD325592
H42A	3G83	660	98.08~03.07	U11C01-COIL	3	ECI	MD346383
H42V	3G83	660	00.01~03.07	U11C01-COIL	3	ECI	MD346383

西暦	1994	95	96	97	98	99	2000	01	02	03	04	05	06	07	08	09	10	11	12	13	14	15	16	17	18	19	20	21	22	23	24	25	26
和暦	平成6	7	8	9	10	11	12	13	14	15	16	17	18	19	20	21	22	23	24	25	26	27	28	29	30	令和元年	2	3	4	5	6	7	8

TOYOTA
トヨタ

NISSAN
日産

HONDA
ホンダ

MAZDA
マツダ

SUBARU
スバル

mitsubishi
三菱

SUZUKI
スズキ

DAIHATSU
ダイハツ

ISUZU
いすゞ

純正品番
対照表-1

Astemo品番
対照表-2

三菱

MITSUBISHI

車両型式	エンジン型式	排気量	年式	Astemo品番	使用数	類別内容	適応純正品番(参考)
------	--------	-----	----	----------	-----	------	------------

トッポ BJ

H46A	4A30	660	98.08~02.07	U13C01-COIL	2	R,TURBO	MD338017
			99.09~01.11	U12C04-COIL	2	MT,SOHC,MITSUBISHI,TURBO	MD308914
			99.09~02.07	U15C01-COIL	2	MT,SOHC,DENSO,TURBO	MD325592
H47A	3G83	660	98.08~03.07	U11C01-COIL	3	ECI	MD346383
H47V	3G83	660	00.01~03.07	U11C01-COIL	3	U,ECI	MD346383

トッポ BJワイド

H43A	4A31	1100	98.11~01.05	U12C04-COIL	2	MITSUBISHI,ECI	MD308914
				U15C01-COIL	2	DENSO,ECI	MD325592
H48A	4A31	1100	98.11~01.05	U12C04-COIL	2	MITSUBISHI,ECI	MD308914
				U15C01-COIL	2	DENSO,ECI	MD325592

トライトン

KB9T	6G74	3500	06.08~10.04	U15C03-COIL	3	NO,2,ECI	MD314583
------	------	------	-------------	-------------	---	----------	----------

パジェロ

V23C	6G72	3000	97.04~99.09	U15C03-COIL	3	NO,2,ECI	MD314583
V63W	6G72	3000	00.06~06.07	U15C03-COIL	3	NO,2,ECI	MD314583
V65W	6G74	3500	99.06~01.06	U11C03-COIL	6	ECI	MD344196
			00.06~05.09	U11C03-COIL	6	GDI	MD366821
V73W	6G72	3000	00.06~06.07	U15C03-COIL	3	NO,2,ECI	MD314583
V75W	6G74	3500	99.06~01.06	U11C03-COIL	6	ECI	MD344196
			00.03~05.09	U11C03-COIL	6	GDI	MD366821

パジェロ イオ

H61W	4G93	1800	99.08~00.04	U11C03-COIL	4	GDI	MD354007
H62W	4G94	2000	00.05~02.08	U11C03-COIL	4	GDI	MD366821
H66W	4G93	1800	98.03~00.04	U11C03-COIL	4	GDI	MD354007
H67W	4G94	2000	00.05~02.08	U11C03-COIL	4	GDI	MD366821
H71W	4G93	1800	99.08~00.04	U11C03-COIL	4	GDI	MD354007
H72W	4G94	2000	00.05~02.08	U11C03-COIL	4	GDI	MD366821
H76W	4G93	1800	98.05~02.08	U11C03-COIL	4	GDI	MD354007
			00.03~05.11	U11C03-COIL	4	TURBO	MD366821
			02.09~05.11	U11C02-COIL	2	ECI	MD362907
			05.12~07.06	U11C02-COIL	2		MD362907
H77W	4G94	2000	00.05~07.05	U11C03-COIL	4	GDI	MD366821

パジェロ ジュニア

H57A	4A31	1100	95.10~98.06	U15C01-COIL	2	ECI	MD325592
------	------	------	-------------	-------------	---	-----	----------

パジェロ ミニ

H51A	4A30	660	95.11~98.10	U12C04-COIL	2	ECI	MD308914
H53A	4A30	660	98.08~99.08	U12C04-COIL	2	MITSUBISHI,ECI	MD308914
				U15C01-COIL	2	DENSO,ECI	MD325592
			99.09~01.11	U12C04-COIL	2	MITSUBISHI,SOHC 除く(TURBO,ECI)	MD308914
			99.09~02.07	U15C01-COIL	2	DENSO,SOHC TURBOなし,ECI	MD325592
				U13C01-COIL	2	DOHC,TURBO	MD338017
02.08~12.06	U15C01-COIL	2	DENSO,TURBO	MD325592			
H56A	4A30	660	94.10~98.08	U12C04-COIL	2	ECI	MD308914
				U13C01-COIL	2	TURBO	MD315999

●印：生産終了品

トヨタ
TOYOTA

日産
NISSAN

ホンダ
HONDA

マツダ
MAZDA

スバル
SUBARU

三菱
MITSUBISHI

スズキ
SUZUKI

ダイハツ
DAIHATSU

いすゞ
ISUZU

対照表-1
純正品番順

対照表-2
Astemo品番順

車両型式	エンジン型式	排気量	年式	Astemo品番	使用数	類別内容	適応純正品番(参考)
------	--------	-----	----	----------	-----	------	------------

パジェロミニ

H58A	4A30	660	98.08~01.11	U12C04-COIL	2	MITSUBISHI,SOHC 除く(TURBO,ECI)	MD308914
			98.08~02.07	U15C01-COIL	2	DENSO,SOHC TURBOなし,ECI	MD325592
				U13C01-COIL	2	DOHC,TURBO	MD338017
			02.08~07.11	U15C01-COIL	2	DENSO,TURBO	MD325592
			07.12~08.07	U15C01-COIL	2	DENSO,SOHC TURBOなし,ECI	MD325592
			07.12~08.04	U15C01-COIL	2	DENSO,SOHC,TURBO	MD325592
			08.04~12.06	U15C01-COIL	1	DENSO,NO.4ｼﾘｰｽﾞ,TURBO	MD325592
				U15C02-COIL	1	DENSO,NO.2ｼﾘｰｽﾞ,TURBO	MN115259

ブラボ-

U43V	4A30	660	95.12~99.08	U13C01-COIL	2	TURBO	MD315999
U44V	4A30	660	95.12~99.08	U13C01-COIL	2	TURBO	MD338017
U61V	3G83	660	01.12~12.05	U11C01-COIL	3	TURBO	MD346383
U62V	3G83	660	01.12~12.05	U11C01-COIL	3	TURBO	MD346383

プラウディア

S32A	6G74	3500	00.02~01.05	U11C03-COIL	6	GDI	MD362913
------	------	------	-------------	-------------	---	-----	----------

ミニカ/ミニカバン

H31A	4A30	660	95.09~98.08	U13C01-COIL	2	TURBO	MD315999
H36A	4A30	660	95.09~98.08	U13C01-COIL	2	TURBO	MD315999
H42A	3G83	660	98.10~07.06	U11C01-COIL	3	ECI	MD346383
H42V	3G83	660	98.08~11.03	U11C01-COIL	3	ECI	MD346383
H47A	3G83	660	98.08~07.07	U11C01-COIL	3	ECI	MD346383
H47V	3G83	660	98.08~11.03	U11C01-COIL	3	ECI	MD346383

ミニカ トップ/ミニカ トップ BJバン

H31A	4A30	660	95.09~98.08	U13C01-COIL	2	TURBO	MD338017
H47V	3G83	660	00.01~03.07	U11C01-COIL	3		MD346383

ミニキャブ

U61T	3G83	660	98.11~12.05	U11C01-COIL	3	ECI	MD346383
			12.06~13.12	U21C01-COIL	3		1832A059
U61TP	3G83	660	98.11~12.05	U11C01-COIL	3	ECI	MD346383
			12.06~12.10	U21C01-COIL	3		1832A059
U61V	3G83	660	98.11~12.05	U11C01-COIL	3	ECI	MD346383
			12.06~13.12	U21C01-COIL	3		1832A059
U62T	3G83	660	98.11~12.05	U11C01-COIL	3	ECI	MD346383
			12.06~13.12	U21C01-COIL	3	4WD	1832A059
U62TP	3G83	660	98.11~13.12	U11C01-COIL	3	ECI	MD346383
U62V	3G83	660	98.11~13.12	U11C01-COIL	3	ECI	MD346383
			12.06~13.12	U21C01-COIL	3	4WD	1832A059

ミラージュ

A03A	3A92	1200	14.11~	U19N02-COIL	3		1832A057
A05A	3A90	1000	12.07~15.10	U19N02-COIL	3		1832A057

ミラージュ ディンゴ

CQ5A	4G93	1800	99.12~02.08	U11C03-COIL	4	GDI	MD354007
------	------	------	-------------	-------------	---	-----	----------

西暦	1994	95	96	97	98	99	2000	01	02	03	04	05	06	07	08	09	10	11	12	13	14	15	16	17	18	19	20	21	22	23	24	25	26
和暦	平成6	7	8	9	10	11	12	13	14	15	16	17	18	19	20	21	22	23	24	25	26	27	28	29	30	令和元年	2	3	4	5	6	7	8

TOYOTA
トヨタ

NISSAN
日産

HONDA
ホンダ

MAZDA
マツダ

SUBARU
スバル

MITSUBISHI
三菱

SUZUKI
スズキ

DAIHATSU
ダイハツ

ISUZU
いすゞ

純正品番
対照表-1

Astemo品番
対照表-2

三菱

MITSUBISHI

車両型式	エンジン 型式	排気量	年 式	Astemo品番	使用数	類 別 内 容	適応純正品番 (参考)
------	------------	-----	-----	----------	-----	---------	----------------

ランサー/ランサーエボリューション

CK5AR	4G93	1800	96.08~00.08	U11C02-COIL	2	ECI	MD325048
CN9A	4G63	2000	96.08~97.08	U12C03-COIL	2	TURBO	MD321461
CP9A	4G63	2000	98.01~00.08	U12C03-COIL	2	TURBO	MD321461
CS5A	4G93	1800	00.03~07.05	U11C03-COIL	4	GDI,TURBO	MD362913
CS5AZ	4G93	1800	05.12~09.10	U11C02-COIL	2	ECI,教習車	MD362907
CS5W	4G93	1800	00.11~07.06	U11C03-COIL	4	GDI,TURBO	MD362913
CS6A	4G94	2000	04.12~08.06	U11C02-COIL	2	ECI	MD362907
CT9A	4G63	2000	00.12~05.01	U12C03-COIL	2	TURBO	MD363552
CT9W	4G63	2000	05.08~06.11	U12C03-COIL	2	5AT,TURBO	MD363552
CVAY12	CR12DE	1200	08.11~13.06	U08108-COIL	4	EGI	MQ701132
CVJY12	MR18DE	1800	08.11~13.06	U15N01-COIL	4	EGI	MQ701133

ランサーカーゴ

CVAY12	CR12DE	1200	08.11~13.06	U08108-COIL	4	2WD	MQ701132
CVJY12	MR18DE	1800	08.11~13.06	U15N01-COIL	4	2WD	MQ701133
CVY12	HR15DE	1500	08.11~	U13N04-COIL	4	2WD	MQ701134
CVZNY12	HR16DE	1600	08.11~	U13N04-COIL	4	4WD	MQ701134

ランサーセディア

CS5A	4G93	1800	00.03~07.05	U11C03-COIL	4	GDI	MD362913
CS5AR	4G93	1800	01.09~05.10	U11C02-COIL	2	ECI,教習車	MD362907
CS5W	4G93	1800	00.11~07.06	U11C03-COIL	4	GDI	MD362913

レグナム

EA1W	4G93	1800	97.06~00.04	U11C03-COIL	4	GDI	MD346866
EA7W	4G94	2000	00.05~02.08	U11C03-COIL	4	GDI	MD362913
EC1W	4G93	1800	97.09~00.04	U11C03-COIL	4	GDI	MD346866
EC7W	4G94	2000	00.05~02.08	U11C03-COIL	4	GDI	MD362913

トヨタ
TOYOTA日産
NISSANホンダ
HONDAマツダ
MAZDAスバル
SUBARU三菱
MITSUBISHIスズキ
SUZUKIダイハツ
DAIHATSUいすゞ
ISUZU対照表-1
純正品番順対照表-2
Astemo品番順

●印：生産終了品

スズキ

SUZUKI

車両型式	エンジン型式	排気量	年式	Astemo品番	使用数	類別内容	適応純正品番(参考)
------	--------	-----	----	----------	-----	------	------------

Kei

HN11S	F6A	660	98.10~01.03	U21S02-COIL	3	4WD	33400-85K10
HN12S	F6A	660	01.04~01.11	U21S02-COIL	3	4WD	33400-85K10
HN21S	K6A	660	98.10~01.04	U21S02-COIL (●U12S01-COIL)	3	EPI,TURBO	33400-76G00
HN22S	K6A	660	01.04~09.09	U21S02-COIL (●U12S01-COIL)	3	EPI,TURBO	33400-76G01

Keiワークス

HN22S	K6A	660	02.11~09.09	U21S02-COIL (●U12S01-COIL)	3		33400-85K10
-------	-----	-----	-------------	-------------------------------	---	--	-------------

MRワゴン

MF21S	K6A	660	01.12~06.01	U21S02-COIL (●U12S01-COIL)	3	EPI,TURBO	33400-76G01
MF22S	K6A	660	06.01~11.01	U21S02-COIL (●U12S01-COIL)	3	EPI,TURBO	33400-76G21
MF33S	R06A	660	11.01~16.03	U19S01-COIL	3	DENSO	33400-64P00

SX4

YA11S	M15A	1500	06.07~14.10	U12S03-COIL	2	EPI,#100001~	33400-65G01
			09.01~14.10	U15S02-COIL	4	EPI,#300001~	33400-51K20
YB11S	M15A	1500	06.07~14.10	U12S03-COIL	2	EPI,#100001~	33400-65G01
			09.01~14.10	U15S02-COIL	4	EPI,#300001~	33400-51K20
YC11S	M15A	1500	07.07~14.10	U12S03-COIL	2	EPI,#100001~	33400-65G01
			09.01~14.10	U15S02-COIL	4	EPI,#300001~	33400-51K20

アルト

HA11S	F6A	660	94.11~97.04	U13S01-COIL	1	SF,LF	33410-71G00
HA12S	F6A	660	98.10~00.12	U21S02-COIL	3	EPI	33400-76G00
				(●U12S01-COIL)			
HA12V	F6A	660	98.10~00.12	U21S02-COIL	3	EPI	33400-76G01
				(●U12S01-COIL)			
HA22S	K6A	660	98.10~02.04	U21S02-COIL	3	EPI	33400-76G00
				(●U12S01-COIL)			
HA23S	K6A	660	00.12~04.09	U21S02-COIL	3	EPI	33400-76G01
				(●U12S01-COIL)			
HA23V	K6A	660	00.12~05.01	U21S02-COIL	3	EPI	33400-76G01
				(●U12S01-COIL)			
HA24S	K6A	660	04.09~09.12	U21S02-COIL	3	EPI	33400-76G01
				(●U12S01-COIL)			
HA24V	K6A	660	04.04~09.12	U21S02-COIL	3	EPI	33400-76G01
				(●U12S01-COIL)			
HA25S	K6A	660	09.12~13.03	U21S02-COIL	3	EPI	33400-76G21
				(●U12S01-COIL)			
HA25V	K6A	660	09.12~12.06	U21S02-COIL	3	EPI	33400-76G21
				(●U12S01-COIL)			
HA36S	R06A	660	14.10~	U19S02-COIL	3		33400-74P00
HA36V	R06A	660	14.10~	U19S02-COIL	3		33400-74P00
HA37S	R06A	660	21.11~	U19S02-COIL	3		33400-74P00
HB11S	F6A	660	97.04~98.09	U13S01-COIL	1	Sedan,I株*,#200001~	33410-71G00

西暦	1994	95	96	97	98	99	2000	01	02	03	04	05	06	07	08	09	10	11	12	13	14	15	16	17	18	19	20	21	22	23	24	25	26
和暦	平成6	7	8	9	10	11	12	13	14	15	16	17	18	19	20	21	22	23	24	25	26	27	28	29	30	令和元年	2	3	4	5	6	7	8

TOYOTA
トヨタ

NISSAN
日産

HONDA
ホンダ

MAZDA
マツダ

SUBARU
スバル

MITSUBISHI
三菱

SUZUKI
スズキ

DAIHATSU
ダイハツ

ISUZU
いすゞ

純正品番
対照表-1

Astemo品番
対照表-2

スズキ

SUZUKI

車両型式	エンジン型式	排気量	年式	Astemo品番	使用数	類別内容	適応純正品番 (参考)
------	--------	-----	----	----------	-----	------	----------------

アルトラパン

HE21S	K6A	660	02.01~08.12	U21S02-COIL ●U12S01-COIL	3	EPI	33400-76G01
			02.10~08.12	U21S02-COIL ●U12S01-COIL	3	EPI,TURBO	33400-76G01
HE22S	K6A	660	08.11~15.06	U21S02-COIL ●U12S01-COIL	3	EPI,TURBO	33400-76G21
HE36S	R06A	660	14.10~	U19S02-COIL	3		33400-74P00

アルトラパン ショコラ

HE22S	K6A	660	13.06~15.06	U21S02-COIL ●U12S01-COIL	3	EPI	33400-76G21
-------	-----	-----	-------------	-----------------------------	---	-----	-------------

アルトワークス

HA22S	K6A	660	98.10~00.12	U21S02-COIL ●U12S01-COIL	3	TURBO	33400-76G00
HA36S	R06A	660	14.10~	U19S02-COIL	3		33400-74P00

イグニス

FF21S	KC12C	1300	16.02~22.08	U22S01-COIL	4		33400-81P00
-------	-------	------	-------------	-------------	---	--	-------------

エスクード

TA02W	G16A	1600	97.11~02.11	U12S04-COIL	2	EPI	33410-66D00
TA11W	H20A	2000	96.02~96.11	U12S02-COIL	6	#100001~	33410-77E20
TA51W	J20A	2000	96.10~97.10	U12S02-COIL	4	EPI	33410-77E20
TA52W	J20A	2000	97.11~02.11	U12S02-COIL	4	EPI	33410-77E21
TA74W	M16A	1600	06.06~08.06	U12S03-COIL	2	EPI	33400-65G01
TD02W	G16A	1600	97.11~00.04	U12S04-COIL	2	EPI	33410-66D00
TD11W	H20A	2000	96.02~96.11	U12S02-COIL	6		33410-77E20
TD51W	J20A	2000	96.10~97.10	U12S02-COIL	4	EPI	33410-77E20
TD52W	J20A	2000	97.11~00.04	U12S02-COIL	4	EPI	33410-77E21
TD61W	H25A	2500	96.10~97.10	U12S02-COIL	6	EPI	33410-77E20
TD62W	H25A	2500	98.02~05.05	U12S02-COIL	6	EPI	33410-77E21
TDA4W	J24B	2400	08.03~	U15S02-COIL	4	EPI	33400-51K20
TL52W	J20A	2000	98.11~05.05	U12S02-COIL	4	EPI	33410-77E21
TX92W	H27A	2700	00.11~05.05	U12S02-COIL	6		33410-77E22
YEH1S	K15C	1500	21.10~	U24S01-COIL	4		33400-76S00

エブリィ/エブリィワゴン

DA17V	R06A	660	15.01~	U19S01-COIL	3	DENSO	33400-64P00
DA17W	R06A	660	15.01~	U19S01-COIL	3	DENSO	33400-64P00
DA52V	F6A	660	99.01~01.09	U21S02-COIL ●U12S01-COIL	3	EPI,除く(TURBO)	33400-76G00
DA62V	K6A	660	01.09~05.08	U21S02-COIL ●U12S01-COIL	3	TURBO	33400-76G01
						EPI	33400-76G01
DA62W	K6A	660	01.09~05.08	U21S02-COIL ●U12S01-COIL	3	TURBO	33400-76G01
						EPI	33400-76G01
DA64V	K6A	660	06.01~15.02	U21S02-COIL ●U12S01-COIL	3	EPI,TURBO	33400-76G20
DA64W	K6A	660	06.01~15.02	U21S02-COIL ●U12S01-COIL	3	EPI,TURBO	33400-76G20
DB52V	F6A	660	99.01~01.09	U21S02-COIL ●U12S01-COIL	3	EPI,除く(TURBO)	33400-76G00

●印：生産終了品

トヨタ
TOYOTA日産
NISSANホンダ
HONDAマツダ
MAZDAスバル
SUBARU三菱
MITSUBISHIスズキ
SUZUKIダイハツ
DAIHATSUいすゞ
ISUZU対照表-1
純正品番順対照表-2
Astemo品番順

スズキ

SUZUKI

車両型式	エンジン型式	排気量	年式	Astemo品番	使用数	類別内容	適応純正品番 (参考)
------	--------	-----	----	----------	-----	------	----------------

エブリィ+(プラス)

DA32W	G13B	1300	99.06~01.05	U12S03-COIL	2	EPI	33400-65G00
-------	------	------	-------------	-------------	---	-----	-------------

エブリィランディ

DA32W	G13B	1300	01.05~05.07	U12S03-COIL	2	EPI	33400-65G01
-------	------	------	-------------	-------------	---	-----	-------------

エリオ

RA21S	M15A	1500	01.11~07.03	U12S03-COIL	2	EPI	33400-65G00
RB21S	M15A	1500	01.01~07.03	U12S03-COIL	2	EPI	33400-65G00
RC51S	M18A	1800	03.01~07.03	U12S03-COIL	2	EPI	33400-65G00
RD51S	M18A	1800	03.01~07.03	U12S03-COIL	2	EPI	33400-65G00

カルタス

GA11S	G13B	1300	98.05~99.05	U12S03-COIL	2	EPI	33400-65G00
GB31S	G16A	1600	98.05~99.05	U12S03-COIL	2	EPI	33400-65G00
GC21S	G15A	1500	98.05~02.07	U12S03-COIL	2	EPI	33400-65G00
GC21W	G15A	1500	98.05~02.07	U12S03-COIL	2	EPI	33400-65G00
GC41W	J18A	1800	98.05~02.07	U12S02-COIL	4	EPI	33410-77E21
GD31S	G16A	1600	98.05~02.07	U12S03-COIL	2	EPI	33400-65G00
GD31W	G16A	1600	98.05~02.07	U12S03-COIL	2	EPI	33400-65G00

カルタス クレセント

GC41W	J18A	1800	96.02~98.05	U12S02-COIL	4	XT,EPI,#140001~	33410-77E21
-------	------	------	-------------	-------------	---	-----------------	-------------

キザシ

RE91S	J24B	2400	09.10~15.12	U15S02-COIL	4	EPI	33400-51K20
RF91S	J24B	2400	09.10~15.12	U15S02-COIL	4	EPI	33400-51K20

キャリイ

DA16T	R06A	660	13.08~22.03	U19S01-COIL	3	DENSO	33400-64P00
DA52T	F6A	660	99.01~01.09	U21S02-COIL (●U12S01-COIL)	3	EPI,除く(TURBO)	33400-76G00
DA62T	K6A	660	01.09~02.05	U21S02-COIL (●U12S01-COIL)	3	EPI	33400-76G01
DA63T	K6A	660	02.05~13.09	U21S02-COIL (●U12S01-COIL)	3	EPI	33400-76G01
DA65T	K6A	660	05.11~13.09	U21S02-COIL (●U12S01-COIL)	3	EPI	33400-76G21
DB52T	F6A	660	99.01~01.09	U21S02-COIL (●U12S01-COIL)	3	除く(TURBO)	33400-76G00

クロスビー

MN71S	KC10C	1000	17.11~	U22S01-COIL	3		33400-81P00
-------	-------	------	--------	-------------	---	--	-------------

シボレーMW

ME34S	M13A	1300	05.12~09.09	U12S03-COIL	2		33400-65G02
-------	------	------	-------------	-------------	---	--	-------------

シボレークルーズ

HR51S	M13A	1300	01.11~03.11	U12S03-COIL	2		33400-65G02
HR52S	M13A	1300	03.11~08.05	U12S03-COIL	2		33400-65G02
HR81S	M15A	1500	02.12~03.11	U12S03-COIL	2		33400-65G02

西暦	1994	95	96	97	98	99	2000	01	02	03	04	05	06	07	08	09	10	11	12	13	14	15	16	17	18	19	20	21	22	23	24	25	26
和暦	平成6	7	8	9	10	11	12	13	14	15	16	17	18	19	20	21	22	23	24	25	26	27	28	29	30	令和元年	2	3	4	5	6	7	8

TOYOTA
トヨタ

NISSAN
日産

HONDA
ホンダ

MAZDA
マツダ

SUBARU
スバル

MITSUBISHI
三菱

SUZUKI
スズキ

DAIHATSU
ダイハツ

ISUZU
いすゞ

純正品番
対照表-1

Astemo品番
対照表-2

スズキ

SUZUKI

車両型式	エンジン 型式	排気量	年 式	Astemo品番	使用数	類 別 内 容	適応純正品番 (参考)
------	------------	-----	-----	----------	-----	---------	----------------

シボレークルーズ

HR82S	M15A	1500	03.11~06.05	U12S03-COIL	2		33400-65G02
-------	------	------	-------------	-------------	---	--	-------------

グランドエスクード

TX92W	H27A	2700	00.11~05.05	U12S02-COIL	6	4AT,EPI	33410-77E21
			03.06~05.05	U12S02-COIL	6	5AT,PFI	33410-77E22

ジムニー

JB23W	K6A	660	98.09~	U21S02-COIL (●U12S01-COIL)	3	TURBO	33400-76G01
JB64W	R06A	660	18.04~	U19S06-COIL	3	4WD	33400-77R00

ジムニー シエラ

JB43W	M13A	1300	02.01~04.10	U12S04-COIL	2	#110001~,EPI	33410-66D01
			06.01~10.09	U12S03-COIL	2	#200001~,EPI	33400-65G01
JB74W	K15B	1500	18.04~	U19S07-COIL	4	4WD	33400-78R00

ジムニー ワイド

JB33W	G13B	1300	98.01~00.04	U12S04-COIL	2	EPI	33410-66D00
JB43W	M13A	1300	00.04~02.01	U12S04-COIL	2	EPI	33410-66D00

スイフト

HT51S	M13A	1300	00.02~05.11	U12S03-COIL	2	EPI	33400-65G00
HT81S	M15A	1500	03.06~04.11	U12S03-COIL	2	EPI	33400-65G01
ZC11S	M13A	1300	04.11~10.09	U12S03-COIL	2	EPI	33400-65G01
ZC21S	M15A	1500	04.11~10.09	U12S03-COIL	2	EPI	33400-65G01
ZC31S	M16A	1600	05.09~10.09	U12S03-COIL	2	EPI	33400-65G01
ZC32S	M16A	1600	11.10~	U15S02-COIL	4	EFI	33400-51K40
ZC71S	K12B	1200	07.04~	U15S02-COIL	4	EPI	33400-51K00
ZC72S	K12B	1200	10.06~	U15S02-COIL	4	除く(XG-DJE,EPI)	33400-51K40
ZD11S	M13A	1300	04.09~	U12S03-COIL	2	EPI	33400-65G01
ZD21S	M15A	1500	04.11~09.05	U12S03-COIL	2	EPI	33400-65G01
ZD72S	K12B	1200	10.09~13.07	U15S02-COIL	4	EPI,XG.#100001~#300000	33400-51K40
ZC13S	KC10C	1000	17.01~20.03	U22S01-COIL	3		33400-81P00
ZC33S	KC14C	1400	17.09~22.08	U22S01-COIL	4		33400-81P00
ZC43S	KC12C	1300	17.07~22.08	U22S01-COIL	4		33400-81P00
ZC53S	KC12C	1300	17.01~22.08	U22S01-COIL	4		33400-81P00
ZC83S	KC12C	1300	17.01~22.08	U22S01-COIL	4		33400-81P00
ZD53S	KC12C	1300	17.01~22.08	U22S01-COIL	4		33400-81P00
ZD83S	KC12C	1300	17.01~22.08	U22S01-COIL	4		33400-81P00

スペースシア

MK32S	R06A	660	13.03~15.05	U19S02-COIL	3		33400-74P00
				U19S01-COIL	3	DENSO	33400-64P00
MK42S	R06A	660	15.03~17.12	U19S02-COIL	3		33400-74P00
				U19S01-COIL	3	DENSO	33400-64P00
MK53S	R06A	660	17.10~	U22S02-COIL	3		33400-63R00

セルボ

CN22S	F6A	660	95.11~98.06	U13S01-COIL	1	トドM	33410-71G00
CP22S	F6A	660	97.05~98.06	U13S01-COIL	1	トドM,#420001~	33410-71G00

●印：生産終了品

スズキ

SUZUKI

車両型式	エンジン型式	排気量	年式	Astemo品番	使用数	類別内容	適応純正品番(参考)
------	--------	-----	----	----------	-----	------	------------

セルボ

HG21S	K6A	660	06.11~09.12	U21S02-COIL (●U12S01-COIL)	3	EPI,TURBO	33400-76G21
			06.11~09.12	U21S02-COIL (●U12S01-COIL)	3	DE,EPI	33400-85K00

ソリオ

MA26S	KC12C	1300	15.07~	U22S01-COIL	4		33400-81P00
MA27S	KC12C	1300	20.08~	U22S01-COIL	4		33400-81P00
MA34S	M13A	1300	05.08~10.12	U12S03-COIL	2	EPI	33400-65G01
MA36S	KC12C	1300	15.07~	U22S01-COIL	4		33400-81P00
MA37S	KC12C	1300	20.08~	U22S01-COIL	4		33400-81P00
MA46S	KC12C	1300	15.07~	U22S01-COIL	4		33400-81P00

ソリオ/ソリオバンディット

MA15S	K12B	1200	11.01~15.08	U15S02-COIL	4	G,#100001~,EPI 除く(S-DJE,Idling stop,#250001~, EPI/GJフィット*#250001~)	33400-51K40
-------	------	------	-------------	-------------	---	--	-------------

ツイン

EC22S	K6A	660	03.01~05.08	U21S02-COIL (●U12S01-COIL)	3	EPI	33400-76G01
-------	-----	-----	-------------	-------------------------------	---	-----	-------------

ハスラー

MR31S	R06A	660	15.09~	U19S02-COIL	3		33400-74P00
			13.10~15.09	U19S01-COIL	3	DENSO	33400-64P00
MR41S	R06A	660	13.10~	U19S02-COIL	3		33400-74P00
			15.09~	U19S01-COIL	3	DENSO	33400-64P00
MR52S	R06A	660	19.09~	U21S01-COIL	3	2WD	33400-59S00
						4WD	33400-59S00
MR92S	R06D	660	19.09~	U21S01-COIL	3	2WD	33400-59S00
						4WD	33400-59S00

パレット

MK21S	K6A	660	08.01~13.03	U21S02-COIL (●U12S01-COIL)	3	EPI,TURBO	33400-76G21
-------	-----	-----	-------------	-------------------------------	---	-----------	-------------

ランディ

SC25	MR20DE	2000	07.01~10.12	U13N04-COIL	4	EGI	33400-50Z01
SNC25	MR20DE	2000	07.01~10.12	U13N04-COIL	4	EGI	33400-50Z01
C27	MR20DD	2000	16.09~	U20N02-COIL	4		33400-52Z10
GC27	MR20DD	2000	16.09~	U20N02-COIL	4		33400-52Z10
GNC27	MR20DD	2000	16.09~	U20N02-COIL	4		33400-52Z10

ワゴンR

MC11S	F6A	660	98.10~00.12	U21S02-COIL (●U12S01-COIL)	3	EPI,TURBO,CNG	33400-76G00
MC21S	K6A	660	98.10~00.12	U21S02-COIL (●U12S01-COIL)	3	EPI,TURBO	33400-76G00
MC22S	K6A	660	00.12~03.09	U21S02-COIL (●U12S01-COIL)	3	EPI,TURBO	33400-76G01

西暦	1994	95	96	97	98	99	2000	01	02	03	04	05	06	07	08	09	10	11	12	13	14	15	16	17	18	19	20	21	22	23	24	25	26
和暦	平成6	7	8	9	10	11	12	13	14	15	16	17	18	19	20	21	22	23	24	25	26	27	28	29	30	令和元年	2	3	4	5	6	7	8

TOYOTA
トヨタ

NISSAN
日産

HONDA
ホンダ

MAZDA
マツダ

SUBARU
スバル

MITSUBISHI
三菱

SUZUKI
スズキ

DAIHATSU
ダイハツ

ISUZU
いすゞ

純正品番
対照表-1

Astemo品番
対照表-2

スズキ

SUZUKI

車両型式	エンジン 型式	排気量	年 式	Astemo品番	使用数	類 別 内 容	適応純正品番 (参考)
------	------------	-----	-----	----------	-----	---------	----------------

ワゴンR

MH21S	K6A	660	03.09~07.05	U21S02-COIL (●U12S01-COIL)	3	EPI,TURBO	33400-76G01
MH22S	K6A	660	07.02~08.09	U21S02-COIL (●U12S01-COIL)	3	EPI	33400-76G21
MH23S	K6A	660	08.09~12.11	U21S02-COIL (●U12S01-COIL)	3	MITSUBISHI	33400-76G21
MH34S	R06A	660	12.09~17.01	U19S01-COIL	3	DENSO	33400-64P00
MH44S	R06A	660	14.08~17.01	U19S01-COIL	3	DENSO	33400-64P00
				U19S02-COIL	3		33400-74P00
MH35S	R06A	660	16.09~	U22S02-COIL	3		33400-63R00
MH55S	R06A	660	16.09~	U22S02-COIL	3		33400-63R00

ワゴンRソリオ

MA34S	M13A	1300	00.12~05.08	U12S03-COIL	2	EPI	33400-65G00
MA64S	K10A	1000	00.11~02.11	U21S02-COIL (●U12S01-COIL)	4	X,DENSO,EPI	33400-76G01

ワゴンRプラス

MA63S	K10A	1000	99.05~00.12	U21S02-COIL (●U12S01-COIL)	4	XV,EPI	33400-76G01
-------	------	------	-------------	-------------------------------	---	--------	-------------

トヨタ
TOYOTA日産
NISSANホンダ
HONDAマツダ
MAZDAスバル
SUBARU三菱
MITSUBISHIスズキ
SUZUKIダイハツ
DAIHATSUいすゞ
ISUZU対照表-1
純正品番順対照表-2
Astemo品番順

●印：生産終了品

ダイハツ

DAIHATSU

車両型式	エンジン型式	排気量	年式	Astemo品番	使用数	類別内容	適応純正品番(参考)
------	--------	-----	----	----------	-----	------	------------

YRV

M200G	EJVE	1000	00.08~02.12	U21D01-COIL	3	EFI	90048-52126-000
M201G	K3VE	1300	00.08~05.07	U15D03-COIL	4	EFI	90048-52130-000
	K3VT	1300	00.08~05.07	U15D03-COIL	4	TURBO	90048-52130-000
M211G	K3VE	1300	00.08~05.07	U15D03-COIL	4	EFI	90048-52130-000
	K3VT	1300	00.08~05.07	U15D03-COIL	4	TURBO	90048-52130-000

アトレー7

S221G	K3VE	1300	00.07~04.11	U15D03-COIL	4	EFI	90048-52130
S231G	K3VE	1300	00.07~04.11	U15D03-COIL	4	EFI	90048-52130

アトレー/アトレーワゴン

S120V	EFGS	660	95.12~98.12	U13D02-COIL	3		90048-52117-000
	EFRS	660	96.12~98.12	U13D01-COIL	3	TURBO	90048-52119-000
	EFZS	660	95.12~98.12	U13D02-COIL	3	EFI	90048-52117-000
S130V	EFGS	660	95.12~98.12	U13D02-COIL	3		90048-52117-000
	EFRS	660	96.12~98.12	U13D01-COIL	3	TURBO	90048-52119-000
	EFZS	660	95.12~98.12	U13D02-COIL	3	EFI	90048-52117-000
S220G	EFDE	660	99.05~04.11	U21D01-COIL	3	TURBO	90048-52126-000
	EFVE	660	99.05~04.11	U21D01-COIL	3	EFI	90048-52126-000
S220V	EFDE	660	98.12~01.12	U21D01-COIL	3	TURBO	90048-52126-000
	EFVE	660	98.12~01.12	U21D01-COIL	3	EFI	90048-52126-000
S230G	EFDE	660	99.05~04.11	U21D01-COIL	3	TURBO	90048-52126-000
	EFVE	660	99.05~04.11	U21D01-COIL	3	EFI	90048-52126-000
S230V	EFDE	660	98.12~01.12	U21D01-COIL	3	TURBO	90048-52126-000
	EFVE	660	98.12~01.12	U21D01-COIL	3	EFI	90048-52126-000
S320G	EFDE	660	04.11~05.11	U21D01-COIL	3	TURBO	90048-52126-000
	EFDET	660	05.12~07.11	U21D01-COIL	3	TURBO	90048-52126
	EFVE	660	05.12~07.11	U21D01-COIL	3	EFI	90048-52126
S321G	KFDET	660	07.08~10.08	U17D01-COIL	3	TURBO	19500-B2030
			10.08~21.12	U18D04-COIL	3	TURBO	19500-B2050
S330G	EFDE	660	04.11~05.11	U21D01-COIL	3	TURBO	90048-52126-000
	EFDET	660	05.12~07.11	U21D01-COIL	3	TURBO	90048-52126
	EFVE	660	05.12~07.11	U21D01-COIL	3	EFI	90048-52126
S331G	KFDET	660	07.08~10.08	U17D01-COIL	3	TURBO	19500-B2030
			10.08~21.12	U18D04-COIL	3	TURBO	19500-B2050
S700V	KFVE	660	21.12~	U24D01-COIL	3		19500-B2070
S710V	KFVE	660	21.12~	U24D01-COIL	3		19500-B2070

アトレーデッキバン

S700W	KFVE	660	21.12~	U24D01-COIL	3		19500-B2070
S710W	KFVE	660	21.12~	U24D01-COIL	3		19500-B2070

アプローズ

A101S	HD	1600	97.09~00.05	U18D02-COIL	2	16Li,SL,16x,EFI	19500-87101-000
-------	----	------	-------------	-------------	---	-----------------	-----------------

アルティス

ACV30N	2AZFE	2400	01.09~06.01	U13T03-COIL	4	EFI	90919-02243
ACV35N	2AZFE	2400	01.09~06.01	U13T03-COIL	4	EFI	90919-02243
ACV40N	2AZFE	2400	06.01~06.04	U13T03-COIL	4	EFI	90919-02244
			06.04~10.02	U13T04-COIL	4	コカイセツソフアビ,EFI	90919-02248
ACV45N	2AZFE	2400	06.01~06.04	U13T03-COIL	4	EFI	90919-02244
			06.04~10.02	U13T04-COIL	4	コカイセツソフアビ,EFI	90919-02248

西暦	1994	95	96	97	98	99	2000	01	02	03	04	05	06	07	08	09	10	11	12	13	14	15	16	17	18	19	20	21	22	23	24	25	26
和暦	平成6	7	8	9	10	11	12	13	14	15	16	17	18	19	20	21	22	23	24	25	26	27	28	29	30	令和元年	2	3	4	5	6	7	8

TOYOTA
トヨタ

NISSAN
日産

HONDA
ホンダ

MAZDA
マツダ

SUBARU
スバル

MITSUBISHI
三菱

SUZUKI
スズキ

DAIHATSU
ダイハツ

ISUZU
いすゞ

純正品番
対照表-1

Astemo品番
対照表-2

ダイハツ

DAIHATSU

車両型式	エンジン型式	排気量	年式	Astemo品番	使用数	類別内容	適応純正品番 (参考)
------	--------	-----	----	----------	-----	------	----------------

アルティス

AVV50N	2ARFXE	2500	12.04~17.04	U13T06-COIL	4	Hybrid,EFI	90919-02256
SXV20N	5SFE	2200	00.03~01.09	U12T18-COIL	1	NO.1,EFI	90919-02217
						NO.2,EFI	90919-02218
SXV25N	5SFE	2200	00.03~01.09	U12T18-COIL	1	NO.1,EFI	90919-02217
						NO.2,EFI	90919-02218

ウェイク

LA700S	KFVE	660	14.10~22.08	U18D04-COIL	3	EFI	19500-B2050
	KFVET	660	14.10~	U18D04-COIL	3	TURBO	19500-B2050
LA710S	KFVE	660	14.10~22.08	U18D04-COIL	3	EFI	19500-B2050
	KFVET	660	14.10~	U18D04-COIL	3	TURBO	19500-B2050

エッセ

L235S	KFVE	660	05.11~10.04	U12D01-COIL	3	EFI	19500-B1010
			05.11~06.12	U17D01-COIL	3	EFI,AT	19500-B2010
			10.04~11.08	U18D04-COIL	3	EFI	19500-B2050
L245S	KFVE	660	05.11~07.07	U17D01-COIL	3	EFI,AT	19500-B2010
			07.07~10.04	U12D01-COIL	3	EFI	19500-B2040
			10.04~11.08	U18D04-COIL	3	EFI	19500-B2050

オブティ

L300S	EFZL	660	95.10~98.08	U13D02-COIL	3	EFI	90048-52117-000
L310S	EFZL	660	95.10~98.08	U13D02-COIL	3	EFI	90048-52117-000
L800S	EFD	660	98.11~02.08	U21D01-COIL	3	TURBO	90048-52126-000
			98.11~01.07	U15D06-COIL	3	EFI	19070-97201-000
			01.07~02.08	U15D04-COIL	3	EFI	19070-97205-000
	EFVE	660	98.11~02.08	U21D01-COIL	3	DENSO ｲｸﾞﾅｲﾀﾞ付ｷ,EFI	90048-52126-000
L802S	EFD	660	98.11~00.02	U11D02-COIL	2	TURBO	90048-52127-000
L810S	EFD	660	98.11~02.08	U21D01-COIL	3	TURBO	90048-52126-000
			98.11~01.07	U15D06-COIL	3	EFI	19070-97201-000
			01.07~02.08	U15D04-COIL	3	EFI	19070-97205-000
	EFVE	660	98.11~02.08	U21D01-COIL	3	DENSO ｲｸﾞﾅｲﾀﾞ付ｷ,EFI	90048-52126-000

コペン

L880K	JBDET	660	02.05~12.08	U15D02-COIL	4	DIAMOND,TURBO	19070-97206-000
			05.10~10.08	U15D02-COIL	4	TURBO	19070-97206
L880	JBDET	660	10.08~12.08	U18D01-COIL	4	V,TURBO	19500-97201
LA400K	KFVET	660	14.05~	U18D04-COIL	3	TURBO	19500-B2050

ストーリーア

M100S	EJDE	1000	98.01~04.08	U21D01-COIL	3	DENSO,EFI	90048-52126-000
	EJVE	1000	98.01~04.08	U21D01-COIL	3	DENSO,EFI	90048-52126-000
M101S	K3VE	1300	00.05~04.05	U15D03-COIL	4	EFI	90048-52130-000
M110S	EJDE	1000	98.01~04.08	U21D01-COIL	3	DENSO,EFI	90048-52126-000
	EJVE	1000	98.01~04.08	U21D01-COIL	3	DENSO,EFI	90048-52126-000
M111S	K3VE	1300	00.05~04.05	U15D03-COIL	4	EFI	90048-52130-000
M112S	JCDET	700	02.07~04.08	U15D02-COIL	4	DIAMOND,TURBO	19070-97206-000

ソニカ

L405S	KFDET	660	06.05~06.09	U17D01-COIL	3	TURBO	19500-B2010
			06.09~09.04	U12D01-COIL	3	TURBO	19500-B1010

●印：生産終了品

トヨタ TOYOTA
日産 NISSAN
ホンダ HONDA
マツダ MAZDA
スバル SUBARU
三菱 MITSUBISHI
スズキ SUZUKI
ダイハツ DAIHATSU
いすゞ ISUZU
対照表-1 純正品番
対照表-2 Astemo品番

ダイハツ

DAIHATSU

車両型式	エンジン型式	排気量	年式	Astemo品番	使用数	類別内容	適応純正品番 (参考)
------	--------	-----	----	----------	-----	------	----------------

ソニカ

L415S	KFDET	660	06.05~06.09	U17D01-COIL	3	TURBO	19500-B2010
			06.09~09.04	U12D01-COIL	3	TURBO	19500-B1010

タフト

LA900	KFV#	660	20.05~	U22D01-COIL	3	FF	19500-B2060
LA910	KFV#	660	20.05~	U22D01-COIL	3	4WD	19500-B2060

タント

L350S	EFDET	660	03.11~07.11	U21D01-COIL	3	TURBO	90048-52126-000
	EFVE	660	03.11~07.11	U21D01-COIL	3	EFI	90048-52126-000
L360S	EFDET	660	03.11~07.11	U21D01-COIL	3	TURBO	90048-52126-000
	EFVE	660	03.11~07.11	U21D01-COIL	3	EFI	90048-52126-000
L375S	KFDET	660	07.12~09.12	U12D01-COIL	3	TURBO	19500-B2040
			09.12~13.09	U18D04-COIL	3	TURBO	19500-B2050
	KFVE	660	07.12~09.12	U12D01-COIL	3	EFI	19500-B2040
			09.12~13.09	U18D04-COIL	3	EFI	19500-B2050
L385S	KFDET	660	07.12~09.12	U12D01-COIL	3	TURBO	19500-B2040
			09.12~13.09	U18D04-COIL	3	TURBO	19500-B2050
	KFVE	660	07.12~09.12	U12D01-COIL	3	EFI	19500-B2040
			09.12~13.09	U18D04-COIL	3	EFI	19500-B2050
LA600S	KFVE	660	13.08~19.07	U18D04-COIL	3	EFI	19500-B2050
	KFVET	660	13.08~19.07	U18D04-COIL	3	TURBO	19500-B2050
LA610S	KFVE	660	13.08~19.07	U18D04-COIL	3	EFI	19500-B2050
	KFVET	660	13.08~19.07	U18D04-COIL	3	TURBO	19500-B2050
LA650	KFV#	660	19.07~	U22D01-COIL	3	FF	19500-B2060
LA660	KFV#	660	19.07~	U22D01-COIL	3	4WD	19500-B2060

タント エグゼ

L455S	KFDET	660	09.12~14.09	U18D04-COIL	3	TURBO	19500-B2050
	KFVE	660	09.12~14.09	U18D04-COIL	3	EFI	19500-B2050
L465S	KFDET	660	09.12~14.09	U18D04-COIL	3	TURBO	19500-B2050
	KFVE	660	09.12~14.09	U18D04-COIL	3	EFI	19500-B2050

タント カスタム

L350S	EFDET	660	05.06~07.11	U21D01-COIL	3	TURBO	90048-52126
	EFVE	660	05.06~07.11	U21D01-COIL	3	EFI	90048-52126
L360S	EFDET	660	05.06~07.11	U21D01-COIL	3	TURBO	90048-52126
	EFVE	660	05.06~07.11	U21D01-COIL	3	EFI	90048-52126
L375S	KFDET	660	07.12~09.12	U12D01-COIL	3	TURBO	19500-B2040
	KFVE	660	07.12~09.12	U12D01-COIL	3	EFI	19500-B2040
L385S	KFDET	660	07.12~09.12	U12D01-COIL	3	TURBO	19500-B2040
	KFVE	660	07.12~09.12	U12D01-COIL	3	EFI	19500-B2040

テリオス

J100G	HCEJ	1300	97.03~00.05	U18D02-COIL	2	EFI	19500-87101-000
J102G	K3VE	1300	00.05~05.12	U15D03-COIL	4	EFI	90048-52130-000
	K3VET	1300	00.05~05.12	U15D03-COIL	4	TURBO	90048-52130-000
J122G	K3VE	1300	00.05~05.12	U15D03-COIL	4	EFI	90048-52130-000

西暦	1994	95	96	97	98	99	2000	01	02	03	04	05	06	07	08	09	10	11	12	13	14	15	16	17	18	19	20	21	22	23	24	25	26
和暦	平成6	7	8	9	10	11	12	13	14	15	16	17	18	19	20	21	22	23	24	25	26	27	28	29	30	令和元年	2	3	4	5	6	7	8

TOYOTA
トヨタ

NISSAN
日産

HONDA
ホンダ

MAZDA
マツダ

SUBARU
スバル

mitsubishi
三菱

SUZUKI
スズキ

DAIHATSU
ダイハツ

ISUZU
いすゞ

純正品番
対照表-1

Astemo品番
対照表-2

ダイハツ

DAIHATSU

車両型式	エンジン型式	排気量	年式	Astemo品番	使用数	類別内容	適応純正品番(参考)
------	--------	-----	----	----------	-----	------	------------

テリオスキッド

J111G	EFDEM	660	98.10~06.08	U21D01-COIL	3	TURBO	90048-52126-000
	EFDET	660	98.10~10.08	U21D01-COIL	3	TURBO	90048-52126-000
			10.08~12.06	U18D03-COIL	3	TURBO,端子4極	19070-97207
J131G	EFDEM	660	98.10~06.08	U21D01-COIL	3	TURBO	90048-52126-000
	EFDET	660	98.10~10.08	U21D01-COIL	3	TURBO	90048-52126-000
			10.08~12.06	U18D03-COIL	3	TURBO,端子4極	19070-97207

テリオスルキア

J111G	EFDEM	660	02.01~03.08	U21D01-COIL	3	EFI	90048-52126-000
J131G	EFDEM	660	02.01~03.08	U21D01-COIL	3	EFI	90048-52126-000

デルタ

RZU300N	3RZFE	2700	00.05~03.06	U12T18-COIL	1	EFI	90919-02217
	3RZFPE	2700	00.05~03.06	U13T07-COIL	4	LPG	90919-02237
RZU340N	3RZFE	2700	00.05~03.06	U12T18-COIL	1	EFI	90919-02217

デルタワイド

YB20G	2YU	1800	82.11~91.12	U12T13-COIL	1		90919-02139-000
YB21G	3YEU	2000	82.11~85.08	U12T13-COIL	1	EFI	90919-02139-000
			85.08~95.08	U12T12-COIL	1	DENSO 029700-5430,EFI	90919-02135-000
			95.08~96.09	U12T13-COIL	1	DENSO 029700-5470,EFI	90919-02139-000
YB25V	2YJ	1800	88.08~96.09	U12T13-COIL	1	DENSO 029700-5470	90919-02139-000
YB26V	1YJ	1600	82.11~88.08	U12T13-COIL	1		90919-02139-000

トール

M900S	1KR-FE	1000	16.11~	U22T02-COIL	3		90919-02281
M910S	1KR-FE	1000	16.11~	U22T02-COIL	3		90919-02281

ネイキッド

L750S	EFDET	660	99.11~03.12	U21D01-COIL	3	TURBO	90048-52126-000
	EFVE	660	99.11~03.12	U21D01-COIL	3	EFI	90048-52126-000
L760S	EFDET	660	99.11~03.12	U21D01-COIL	3	TURBO	90048-52126-000
	EFVE	660	99.11~03.12	U21D01-COIL	3	EFI	90048-52126-000

ハイゼット/ハイゼットカーゴ

S100C	EFGS	660	95.12~98.12	U13D02-COIL	3		90048-52117-000
S100CT	EFGS	660	95.12~98.12	U13D02-COIL	3		90048-52117-000
S100P	EFGS	660	95.12~98.12	U13D02-COIL	3	AT	90048-52117-000
S100V	EFGS	660	95.12~98.12	U13D02-COIL	3		90048-52117-000
	EFZS	660	95.12~98.12	U13D02-COIL	3	EFI	90048-52117-000
S100W	EFZS	660	95.12~98.12	U13D02-COIL	3	EFI	90048-52117-000
S110P	EFGS	660	95.12~98.12	U13D02-COIL	3	AT,EFI	90048-52117-000
S110V	EFGS	660	95.12~98.12	U13D02-COIL	3		90048-52117-000
	EFZS	660	95.12~98.12	U13D02-COIL	3	EFI	90048-52117-000
S110W	EFGS	660	95.12~98.12	U13D02-COIL	3		90048-52117-000
S200C	EFSE	660	98.12~04.11	U15D01-COIL	3	除く(CNG,EFI)	19070-97204-000
			04.11~07.11	U15D01-COIL	3	EFI	19070-97204-000
	EFVE	660	98.12~05.11	U21D01-COIL	3	EFI	90048-52126-000
			05.12~07.11	U21D01-COIL	3	EFI,AT	90048-52126
				U15D01-COIL	3	EFI,MT	19070-97501

●印：生産終了品

車両型式	エンジン型式	排気量	年式	Astemo品番	使用数	類別内容	適応純正品番(参考)
------	--------	-----	----	----------	-----	------	------------

ハイゼット/ハイゼットカーゴ

S200P	EFSE	660	98.12~04.11	U15D01-COIL	3	除く(CNG,EFI)	19070-97204-000
			04.11~07.11	U15D01-COIL	3	EFI	19070-97204-000
	EFVE	660	98.12~04.11	U21D01-COIL	3	DENSO ｲｸﾞﾅｲﾀﾞ付ｷ,EFI	90048-52126-000
			00.09~04.11	U15D01-COIL	3	ｽﾌﾟﾘ,除く(CNG,EFI,AT)	19070-97204-000
			01.09~04.11	U21D01-COIL	3	DENSO ｲｸﾞﾅｲﾀﾞ付ｷ DOHC CNG,EFI	90048-52126-000
			05.12~07.11	U21D01-COIL	3	Extra,EFI	90048-52126
U15D01-COIL	3	ｽﾀｸﾞｰﾄﾞ,EFI		19070-97501			
S200V	EFDE	660	98.12~04.11	U21D01-COIL	3	TURBO	90048-52126-000
	EFSE	660	98.12~04.11	U15D01-COIL	3	除く(CNG,EFI)	19070-97204-000
			01.09~02.12	U21D01-COIL	3	DOHC CNG,EFI	90048-52126-000
	EFVE	660	98.12~04.11	U21D01-COIL	3	EFI	90048-52126-000
EFVN	660	98.12~04.11	U21D01-COIL	3	CNG	90048-52126-000	
S200W	EFSE	660	98.12~04.11	U15D01-COIL	3	除く(CNG,EFI)	19070-97204-000
	EFVE	660	98.12~04.11	U21D01-COIL	3	EFI	90048-52126-000
S201C	KFVE	660	07.12~10.08	U17D01-COIL	3	EFI	19500-B2030
			10.08~14.07	U18D04-COIL	3	EFI	19500-B2050
S201P	KFVE	660	07.12~10.08	U17D01-COIL	3	EFI	19500-B2030
			10.08~14.07	U18D04-COIL	3	EFI	19500-B2050
S210C	EFSE	660	98.12~04.11	U15D01-COIL	3	除く(CNG,EFI)	19070-97204-000
			04.11~07.11	U15D01-COIL	3	EFI	19070-97501-000
	EFVE	660	05.12~07.11	U15D01-COIL	3	EFI	19070-97501
S210P	EFSE	660	98.12~04.11	U15D01-COIL	3	除く(CNG,EFI)	19070-97204-000
			04.11~07.11	U15D01-COIL	3	EFI	19070-97501-000
	EFVE	660	98.12~07.11	U21D01-COIL	3	EFI	90048-52126-000
S210V	EFDE	660	98.12~04.11	U21D01-COIL	3	TURBO	90048-52126-000
	EFSE	660	98.12~04.11	U15D01-COIL	3	除く(CNG,EFI)	19070-97204-000
	EFVE	660	98.12~04.11	U21D01-COIL	3	EFI	90048-52126-000
	EFVN	660	98.12~04.11	U21D01-COIL	3	CNG	90048-52126-000
S210W	EFSE	660	98.12~04.11	U15D01-COIL	3	除く(CNG,EFI)	19070-97204-000
	EFVE	660	98.12~04.11	U21D01-COIL	3	EFI	19070-97204-000
S211C	KFVE	660	07.12~10.08	U17D01-COIL	3	EFI	19500-B2030
			10.08~14.07	U18D04-COIL	3	EFI	19500-B2050
S211P	KFVE	660	07.12~10.08	U17D01-COIL	3	EFI	19500-B2030
			10.08~14.07	U18D04-COIL	3	EFI	19500-B2050
S221V	K3VE	1300	01.07~04.11	U15D03-COIL	4	EFI	90048-52130-000
S231V	K3VE	1300	01.07~04.11	U15D03-COIL	4	EFI	90048-52130-000
S320V	EFDE	660	04.11~05.11	U21D01-COIL	3	TURBO	90048-52126-000
	EFDET	660	05.12~07.11	U21D01-COIL	3	TURBO	90048-52126
	EFSE	660	04.11~07.11	U15D01-COIL	3	EFI	19070-97501-000
	EFVE	660	04.11~07.11	U21D01-COIL	3	EFI	90048-52126-000
			07.12~10.03	U21D01-COIL	3	Hybrid,EFI	90048-52126
EFVN	660	07.12~10.03	U21D01-COIL	3	CNG	90048-52126	
S320W	EFSE	660	04.11~07.11	U15D01-COIL	3	EFI	19070-97501-000
S321V	KFDET	660	07.08~10.08	U17D01-COIL	3	TURBO	19500-B2030
			10.08~20.08	U18D04-COIL	3	TURBO	19500-B2050
	KFVE	660	07.08~10.08	U17D01-COIL	3	EFI	19500-B2030
			10.08~21.12	U18D04-COIL	3	EFI	19500-B2050
	KFVN	660	07.08~17.11	U17D01-COIL	3	CNG	19500-B2030
	EFVN	660	07.12~10.03	U21D01-COIL	3	CNG	90048-52126
KFVE	660	07.12~10.08	U12D01-COIL	3	EFI	19500-B2040	
S321W	KFVE	660	07.08~10.08	U17D01-COIL	3	EFI	19500-B2030
			10.08~21.12	U18D04-COIL	3	EFI	19500-B2050

西暦	1994	95	96	97	98	99	2000	01	02	03	04	05	06	07	08	09	10	11	12	13	14	15	16	17	18	19	20	21	22	23	24	25	26
和暦	平成6	7	8	9	10	11	12	13	14	15	16	17	18	19	20	21	22	23	24	25	26	27	28	29	30	令和元年	2	3	4	5	6	7	8

TOYOTA
トヨタ

NISSAN
日産

HONDA
ホンダ

MAZDA
マツダ

SUBARU
スバル

mitsubishi
三菱

SUZUKI
スズキ

DAIHATSU
ダイハツ

ISUZU
いすゞ

純正品番
対照表-1

Astemo品番
対照表-2

ダイハツ

DAIHATSU

車両型式	エンジン型式	排気量	年式	Astemo品番	使用数	類別内容	適応純正品番 (参考)
------	--------	-----	----	----------	-----	------	----------------

ハイゼット/ハイゼットカーゴ

S330V	EFDE	660	04.11~05.11	U21D01-COIL	3	TURBO	90048-52126-000
	EFDET	660	05.12~07.11	U21D01-COIL	3	TURBO	90048-52126
	EFSE	660	04.11~07.11	U15D01-COIL	3	EFI	19070-97501-000
	EFVE	660	04.11~07.11	U21D01-COIL	3	EFI	90048-52126-000
	EFVN	660	07.12~10.03	U21D01-COIL	3	AT,CNG	90048-52126
MT,CNG						90048-52126	
S330W	EFSE	660	04.11~07.11	U15D01-COIL	3	EFI	19070-97501-000
	EFVE	660	04.11~07.11	U21D01-COIL	3	EFI	90048-52126-000
S331V	KFDET	660	07.08~10.08	U17D01-COIL	3	TURBO	19500-B2030
			10.08~20.08	U18D04-COIL	3	TURBO	19500-B2050
	KFVE	660	07.08~10.08	U17D01-COIL	3	EFI	19500-B2030
			10.08~21.12	U18D04-COIL	3	EFI	19500-B2050
	KFVN	660	07.08~17.11	U17D01-COIL	3	CNG	19500-B2030
	EFVN	660	07.12~10.03	U21D01-COIL	3	CNG	90048-52126
	KFVE	660	07.12~10.08	U12D01-COIL	3	EFI	19500-B2040
S331W	KFVE	660	07.08~10.08	U17D01-COIL	3	EFI	19500-B2030
			10.08~21.12	U18D04-COIL	3	EFI	19500-B2050
S500P	KF	660	14.07~21.12	U18D04-COIL	3	EFI	19500-B2050
S510P	KF	660	14.07~21.12	U18D04-COIL	3	EFI	19500-B2050
S700V	KFVE	660	21.12~	U24D01-COIL	3		19500-B2070
S710V	KFVE	660	21.12~	U24D01-COIL	3		19500-B2070

ハイゼットデッキバン

S700V	KFVE	660	21.12~	U24D01-COIL	3		19500-B2070
S710V	KFVE	660	21.12~	U24D01-COIL	3		19500-B2070

ハイゼットトラック

S500P	KF	660	21.12~	U24D01-COIL	3		19500-B2070
S510P	KF	660	21.12~	U24D01-COIL	3		19500-B2070

ブーン

M300S	1KRFE	1000	04.05~10.02	U13T05-COIL	3	EFI	90919-02239
M310S	1KRFE	1000	04.05~10.02	U13T05-COIL	3	EFI	90919-02239
M600S	1KRFE	1000	10.02~16.04	U18D04-COIL	3	EFI	19500-B2050
M610S	1KRFE	1000	10.02~16.04	U18D04-COIL	3	EFI	19500-B2050
M700S	1KR-FE	1000	16.04~23.12	U22T02-COIL	3		90919-02281
M710S	1KR-FE	1000	16.04~23.12	U22T02-COIL	3		90919-02281

マックス

L950S	EFDET	660	01.11~05.11	U21D01-COIL	3	DENSO ｲｸﾞﾅｲﾀﾞ付ｷ,TURBO	90048-52126-000
	EFVE	660	01.11~05.11	U21D01-COIL	3	DENSO ｲｸﾞﾅｲﾀﾞ付ｷ,EFI	90048-52126-000
L952S	JBDET	660	01.11~05.11	U15D02-COIL	4	DIAMOND,TURBO	19070-97206-000
L960S	EFDET	660	01.11~05.11	U21D01-COIL	3	DENSO ｲｸﾞﾅｲﾀﾞ付ｷ,TURBO	90048-52126-000
	EFVE	660	01.11~05.11	U21D01-COIL	3	DENSO ｲｸﾞﾅｲﾀﾞ付ｷ,EFI	90048-52126-000
L962S	JBDET	660	01.11~05.11	U15D02-COIL	4	DIAMOND,TURBO	19070-97206-000

●印：生産終了品

車両型式	エンジン型式	排気量	年式	Astemo品番	使用数	類別内容	適応純正品番 (参考)
------	--------	-----	----	----------	-----	------	----------------

ミラ/ミラカスタム

L250S	EFSE	660	02.12~06.12	U15D04-COIL	3	EFI	19070-97205-000
	EFVD	660	02.12~06.12	U21D01-COIL	3	EFI	90048-52126-000
	EFVE	660	02.12~06.12	U21D01-COIL	3	EFI	90048-52126-000
L250V	EFSE	660	02.12~07.11	U15D04-COIL	3	EFI	19070-97205-000
	EFVE	660	02.12~07.11	U21D01-COIL	3	EFI	90048-52126-000
	EFVN	660	02.12~07.11	U21D01-COIL	3	CNG	90048-52126-000
L260S	EFSE	660	02.12~06.12	U15D04-COIL	3	EFI	19070-97205-000
	EFVE	660	02.12~06.12	U21D01-COIL	3	EFI	90048-52126-000
L260V	EFSE	660	02.12~07.11	U15D04-COIL	3	EFI	19070-97205-000
	EFVN	660	02.12~07.11	U21D01-COIL	3	CNG	90048-52126-000
L275S	KFDET	660	06.12~10.04	U12D01-COIL	3	TURBO	19500-B1010
			10.04~10.07	U18D04-COIL	3	TURBO	19500-B2050
	KFVE	660	06.12~10.04	U12D01-COIL	3	EFI	19500-B1010
			10.04~18.01	U18D04-COIL	3	EFI	19500-B2050
L275V	KFVE	660	07.07~10.04	U12D01-COIL	3	EFI	19500-B2040
			10.04~18.01	U18D04-COIL	3	EFI	19500-B2050
	KFVN	660	07.07~11.07	U12D01-COIL	3	CNG	19500-B2040
L285S	KFDET	660	06.12~10.04	U12D01-COIL	3	TURBO	19500-B1010
			10.04~10.07	U18D04-COIL	3	TURBO	19500-B2050
	KFVE	660	06.12~10.04	U12D01-COIL	3	EFI	19500-B1010
			10.04~18.01	U18D04-COIL	3	EFI	19500-B2050
L285V	KFVE	660	07.07~10.04	U12D01-COIL	3	EFI	19500-B2040
			10.04~18.01	U18D04-COIL	3	EFI	19500-B2050
L500S	EFGL	660	95.10~98.08	U13D02-COIL	3		90048-52117-000
	EFRL	660	95.10~98.08	U13D01-COIL	3	TURBO	90048-52119-000
	EFZL	660	95.10~98.08	U13D02-COIL	3	EFI	90048-52117-000
L502S	JBEL	660	94.08~98.08	U11D01-COIL	2	EFI	90048-52111-000
	JBUL	660	94.08~98.08	U11D01-COIL	2	TURBO	90048-52111-000
L510S	EFRL	660	95.10~98.08	U13D01-COIL	3	TURBO	90048-52119-000
	EFZL	660	95.10~98.08	U13D02-COIL	3	EFI	90048-52117-000
L512S	JBUL	660	94.08~98.08	U11D01-COIL	2	TURBO	90048-52111-000
L650S	EFVE	660	04.11~08.12	U18D03-COIL	3	EFI,端子4極	19070-97207-000
L660S	EFVE	660	04.11~08.12	U21D01-COIL	3	EFI	90048-52126-000
L700S	EFDE	660	98.10~02.12	U21D01-COIL	3	TURBO	90048-52126-000
			98.10~01.07	U15D06-COIL	3	EFI	19070-97201-000
	EFSE	660	01.07~02.12	U15D04-COIL	3	EFI	19070-97205-000
			98.10~02.12	U21D01-COIL	3	EFI	90048-52126-000
L700V	EFSE	660	98.10~01.07	U15D06-COIL	3	EFI	19070-97201-000
			01.07~02.12	U15D04-COIL	3	EFI	19070-97205-000
	EFVE	660	98.10~02.12	U21D01-COIL	3	EFI	90048-52126-000
			98.10~02.12	U21D01-COIL	3	DENSO ｲｸﾞﾅｲｲ付ｷ,CNG	90048-52126-000
			98.10~02.12	U21D01-COIL	3	TURBO	90048-52126-000
L710S	EFDE	660	98.10~02.12	U21D01-COIL	3	TURBO	90048-52126-000
			98.10~01.07	U15D06-COIL	3	EFI	19070-97201-000
	EFSE	660	01.07~02.12	U15D04-COIL	3	EFI	19070-97205-000
			98.10~02.12	U21D01-COIL	3	DENSO ｲｸﾞﾅｲｲ付ｷ,EFI	90048-52126-000
L710V	EFSE	660	98.10~01.07	U15D06-COIL	3	EFI	19070-97201-000
			01.07~02.12	U15D04-COIL	3	EFI	19070-97205-000
	EFVN	660	98.10~02.12	U21D01-COIL	3	DENSO ｲｸﾞﾅｲｲ付ｷ,CNG	90048-52126-000

西暦	1994	95	96	97	98	99	2000	01	02	03	04	05	06	07	08	09	10	11	12	13	14	15	16	17	18	19	20	21	22	23	24	25	26
和暦	平成6	7	8	9	10	11	12	13	14	15	16	17	18	19	20	21	22	23	24	25	26	27	28	29	30	令和元年	2	3	4	5	6	7	8

TOYOTA
トヨタ

NISSAN
日産

HONDA
ホンダ

MAZDA
マツダ

SUBARU
スバル

mitsubishi
三菱

SUZUKI
スズキ

DAIHATSU
ダイハツ

ISUZU
いすゞ

純正品番順
対照表-1

Astemo品番順
対照表-2

ダイハツ

DAIHATSU

車両型式	エンジン型式	排気量	年式	Astemo品番	使用数	類別内容	適応純正品番(参考)
------	--------	-----	----	----------	-----	------	------------

ミラアヴィ

L250S	EFDET	660	02.12~06.12	U21D01-COIL	3	TURBO	90048-52126-000
	EFVE	660	02.12~06.12	U21D01-COIL	3	EFI	90048-52126-000
L260S	EFDET	660	02.12~06.12	U21D01-COIL	3	TURBO	90048-52126-000
	EFVE	660	02.12~06.12	U21D01-COIL	3	EFI	90048-52126-000

ミライース

LA300S	KFVE	660	11.08~17.04	U18D04-COIL	3	EFI	19500-B2050
LA310S	KFVE	660	11.08~17.04	U18D04-COIL	3	EFI	19500-B2050

ミラココア

L675S	KFVE	660	09.07~18.02	U18D04-COIL	3	EFI	19500-B2050
L685S	KFVE	660	09.07~18.02	U18D04-COIL	3	EFI	19500-B2050

ミラジーノ

L660S	EFVE	660	04.11~09.03	U21D01-COIL	3		90048-52126
L700S	EFDET	660	99.02~04.10	U21D01-COIL	3	TURBO	90048-52126-000
	EFVE	660	00.09~04.10	U21D01-COIL	3	EFI	90048-52126-000
L710S	EFDET	660	99.02~04.10	U21D01-COIL	3	TURBO	90048-52126-000
	EFVE	660	99.02~04.10	U21D01-COIL	3	DENSO ｲﾝﾀﾞｲ付ｷ,EFI	90048-52126-000

ミラジーノ1000

L701S	EJVE	1000	02.08~04.10	U21D01-COIL	3	EFI	90048-52126-000
L711S	EJVE	1000	02.08~04.10	U21D01-COIL	3	EFI	90048-52126-000

ムーヴ/ムーヴカスタム

L150S	EFDET	660	02.10~06.09	U21D01-COIL	3	DENSO,TURBO	90048-52126-000
	EFVE	660	02.10~04.12	U21D01-COIL	3	DENSO,EFI	90048-52126-000
			04.12~06.09	U18D03-COIL	3	L,EFI,端子4極	19070-97207-000
			04.12~05.08	U21D01-COIL	3	ｶｽﾀﾑX,DENSO,EFI	90048-52126-000
			05.08~06.09	U21D01-COIL	3	ｶｽﾀﾑX,DIAMOND,EFI	90048-52125
L152S	JBDET	660	02.10~05.08	U15D02-COIL	4	DIAMOND,TURBO	19070-97206-000
			05.08~06.10	U15D02-COIL	4	TURBO	19070-97206
L160S	EFDET	660	02.10~06.09	U21D01-COIL	3	DENSO,TURBO	90048-52126-000
	EFVE	660	02.10~05.08	U21D01-COIL	3	DENSO,EFI	90048-52126-000
			05.08~06.09	U21D01-COIL	3	DIAMOND,EFI	90048-52125
L175S	KFDET	660	06.10~09.12	U12D01-COIL	3	TURBO	19500-B1010
			09.12~10.12	U18D04-COIL	3	TURBO	19500-B2050
	KFVE	660	06.10~09.12	U12D01-COIL	3	EFI	19500-B1010
			09.12~10.12	U18D04-COIL	3	EFI	19500-B2050
L185S	KFDET	660	06.10~09.12	U12D01-COIL	3	TURBO	19500-B1010
			09.12~10.12	U18D04-COIL	3	TURBO	19500-B2050
	KFVE	660	06.10~09.12	U12D01-COIL	3	EFI	19500-B1010
			09.12~10.12	U18D04-COIL	3	EFI	19500-B2050
L600S	EFGL	660	95.08~98.09	U13D02-COIL	3		90048-52117-000
	EFRL	660	96.04~98.09	U13D01-COIL	3	TURBO	90048-52119-000
	EFZL	660	95.08~98.09	U13D02-COIL	3	EFI	90048-52117-000
L602S	JB JL	660	95.08~98.09	U11D01-COIL	2	TURBO	90048-52111-000
L610S	EFRL	660	96.04~98.09	U13D01-COIL	3	TURBO	90048-52119-000
	EFZL	660	95.08~98.09	U13D02-COIL	3	EFI	90048-52117-000
L900S	EFDET	660	98.10~02.09	U21D01-COIL	3	TURBO	90048-52126-000
	EFSE	660	98.10~00.09	U15D06-COIL	3	EFI	19070-97201-000
	EFVE	660	98.10~02.09	U21D01-COIL	3	EFI	90048-52126-000

●印：生産終了品

ダイハツ

DAIHATSU

車両型式	エンジン型式	排気量	年式	Astemo品番	使用数	類別内容	適応純正品番(参考)
------	--------	-----	----	----------	-----	------	------------

ムーヴ/ムーヴ カスタム

L902S	JBDET	660	98.10~01.09	U11D02-COIL	2	TURBO	90048-52127-000
			01.09~02.09	U15D02-COIL	4	DIAMOND,TURBO	19070-97206-000
L910S	EFDET	660	98.10~02.09	U21D01-COIL	3	TURBO	90048-52126-000
	EFVE	660	98.10~02.09	U21D01-COIL	3	EFI	90048-52126-000
L912S	JBDET	660	01.09~02.09	U15D02-COIL	4	DIAMOND,TURBO	19070-97206-000
LA100S	KFDET	660	10.12~14.11	U18D04-COIL	3	TURBO	19500-B2050
	KFVE	660	10.12~14.11	U18D04-COIL	3	EFI	19500-B2050
LA110S	KFDET	660	10.12~14.11	U18D04-COIL	3	TURBO	19500-B2050
	KFVE	660	10.12~14.11	U18D04-COIL	3	EFI	19500-B2050
LA150S	KFDET	660	14.11~	U18D04-COIL	3	TURBO	19500-B2050
	KFVE	660	14.11~23.07	U18D04-COIL	3	EFI	19500-B2050
LA160S	KFDET	660	14.11~	U18D04-COIL	3	TURBO	19500-B2050
	KFVE	660	14.11~23.07	U18D04-COIL	3	EFI	19500-B2050

ムーヴ コンテ/ムーヴコンテ カスタム

L575S	KFDET	660	08.08~09.12	U12D01-COIL	3	TURBO	19500-B2040
			09.12~17.01	U18D04-COIL	3	TURBO	19500-B2050
	KFVE	660	08.08~09.12	U12D01-COIL	3	EFI	19500-B2040
			09.12~17.01	U18D04-COIL	3	EFI	19500-B2050
L585S	KFDET	660	08.08~09.12	U12D01-COIL	3	TURBO	19500-B2040
			09.12~17.01	U18D04-COIL	3	TURBO	19500-B2050
	KFVE	660	08.08~09.12	U12D01-COIL	3	EFI	19500-B2040
			09.12~17.01	U18D04-COIL	3	EFI	19500-B2050

ムーヴ ラテ

L550S	EFDET	660	04.08~09.03	U21D01-COIL	3	TURBO	90048-52126-000
	EFVE	660	04.08~05.05	U21D01-COIL	3	DENSO,EFI	90048-52126-000
			04.08~05.05	U18D03-COIL	3	DIAMOND,EFI,端子4極	19070-97207-000
			05.05~07.05	U21D01-COIL	3	X,COOL,EFI	90048-52126
			05.05~08.12	U18D03-COIL	3	L,EFI,端子4極	19070-97207
			07.05~09.03	U21D01-COIL	3	COOLVS,VS,EFI	90048-52126
L560S	EFDET	660	04.08~09.03	U21D01-COIL	3	TURBO	90048-52126-000
	EFVE	660	04.08~05.05	U21D01-COIL	3	DENSO,EFI	90048-52126-000
			05.05~09.03	U21D01-COIL	3	L,COOL,EFI	90048-52126

メビウス

ZVW41N	2ZRF	1800	13.04~21.03	U19T14-COIL	4		90919-02258
--------	------	------	-------------	-------------	---	--	-------------

ロッキー

A200S	1KR-VET	1000	19.10~21.11	U22T02-COIL	3		90919-02281
A210S	1KR-VET	1000	19.10~	U22T02-COIL	3		90919-02281

西暦	1994	95	96	97	98	99	2000	01	02	03	04	05	06	07	08	09	10	11	12	13	14	15	16	17	18	19	20	21	22	23	24	25	26
和暦	平成6	7	8	9	10	11	12	13	14	15	16	17	18	19	20	21	22	23	24	25	26	27	28	29	30	令和元年	2	3	4	5	6	7	8

TOYOTA
トヨタ

NISSAN
日産

HONDA
ホンダ

MAZDA
マツダ

SUBARU
スバル

MITSUBISHI
三菱

SUZUKI
スズキ

DAIHATSU
ダイハツ

ISUZU
いすゞ

純正品番順
対照表-1

Astemo品番順
対照表-2

いすゞ

ISUZU

車両型式	エンジン 型式	排気量	年 式	Astemo品番	使用数	類 別 内 容	適応純正品番 (参考)
------	------------	-----	-----	----------	-----	---------	----------------

エルフ

ASQ1F24	QR20DE	2000	07.06~	U13N04-COIL	4	EGI	5-86141-317-0
ASQ2F24	QR20DE	2000	07.06~	U13N04-COIL	4	EGI	5-86141-317-0

コモ

JCSGE25	QR25DE	2500	07.08~12.07	U13N04-COIL	4	EGI	5-86141-317-0
JDSGE25	QR25DE	2500	07.08~12.07	U13N04-COIL	4	EGI	5-86141-317-0
JSE25	QR25DE	2500	07.08~12.07	U13N04-COIL	4	EGI	5-86141-317-0
JSGE25	QR25DE	2500	07.08~12.07	U13N04-COIL	4	EGI	5-86141-317-0
JVRE25	QR20DE	2000	07.08~12.07	U13N04-COIL	4	EGI	5-86141-317-0

トヨタ
TOYOTA日産
NISSANホンダ
HONDAマツダ
MAZDAスバル
SUBARU三菱
MITSUBISHIスズキ
SUZUKIダイハツ
DAIHATSUいすゞ
ISUZU対照表-1
純正品番順対照表-2
Astemo品番順

●印：生産終了品

品番対照表 (純正品番順)

純正品番	Astemo品番
トヨタ TOYOTA	
19070-B1011	U20T02-COIL
19070-BZ031	U21T04-COIL
19500-87101	U18D02-COIL
19500-B2050	U18D04-COIL
19500-B2051	U18D04-COIL
19500-B2070	U24D01-COIL
90048-52126	U21D01-COIL
90048-52130	U15D03-COIL
90919-02135	U12T12-COIL
90919-02139	U12T13-COIL
90919-02163	U12T14-COIL
90919-02164	U12T01-COIL
90919-02197	U12T02-COIL
90919-02216	U22T01-COIL
90919-02217	U12T18-COIL
90919-02218	U12T18-COIL
90919-02220	U12T18-COIL
90919-02229	U13T01-COIL
90919-02230	U13T02-COIL
90919-02234	U19T11-COIL
90919-02237	U13T07-COIL
90919-02239	U13T05-COIL
90919-02240	U13T01-COIL
90919-02243	U13T03-COIL
90919-02244	U13T03-COIL
90919-02247	U13T04-COIL
90919-02248	U13T04-COIL
90919-02250	U13T06-COIL
90919-02251	U19T15-COIL
90919-02255	U19T15-COIL
90919-02256	U13T06-COIL
90919-02257	U20T03-COIL
90919-02258	U19T14-COIL
90919-02260	U13T04-COIL
90919-02262	U13T05-COIL
90919-02265	U13T08-COIL
90919-02266	U13T03-COIL
90919-02269	U23T03-COIL
90919-02270	U23T04-COIL
90919-02271	U23T06-COIL
90919-02272	U21T01-COIL
90919-02273	U23T05-COIL
90919-02276	U23T02-COIL
90919-02277	U23T01-COIL
90919-02281	U22T02-COIL
90919-C2002	U13T04-COIL
90919-C2004	U13T06-COIL
90919-C2006	U13T04-COIL
90919-T2005	U13T04-COIL

純正品番	Astemo品番
トヨタ TOYOTA	
SU003-05259	U23T07-COIL
日産 NISSAN	
22433-25U00	● U09104-COIL
22433-59S11	● U09111-COIL
22433-59S12	● U09111-COIL
22433-60U01	U09121-COIL
22433-60U02	U09121-COIL
22433-8H315	U08103-COIL
22433-8J11C	U16N01-COIL
22433-AA000	U09110-COIL
22433-AL61C	U08105-COIL
22433-HA001	U22M01-COIL
22448-02U10	U09122-COIL
22448-02U11	U09122-COIL
22448-1KCOA	U17N01-COIL
22448-1KTOA	U13N04-COIL
22448-1KTOB	U20N01-COIL
22448-25U00	U09105-COIL
22448-2Y000	U09115-COIL
22448-2Y001	● U09116-COIL
22448-2Y005	U09118-COIL
22448-2Y006	U09119-COIL
22448-2Y007	U09119-COIL
22448-2Y502	U09113-COIL
22448-2Y700	U09114-COIL
22448-31U00	U09101-COIL
22448-31U01	U09101-COIL
22448-31U05	U09106-COIL
22448-31U06	U09106-COIL
22448-31U11	U09101-COIL
22448-31U16	U09106-COIL
22448-3H000	U09103-COIL
22448-3HD0A	U13N03-COIL
22448-3HD0B	U13N03-COIL
22448-3HD0C	U13N03-COIL
22448-4A00A	U21S02-COIL (● U12S01-COIL)
22448-4A00B	U21S02-COIL (● U12S01-COIL)
22448-4A00D	U21S02-COIL (● U12S01-COIL)
22448-4A00F	U21S02-COIL (● U12S01-COIL)
22448-4A00G	U19S01-COIL
22448-4A00H	U19S01-COIL
22448-4A01A	U19S01-COIL
22448-4A01B	U19S01-COIL
22448-4A0A0	U21S02-COIL
22448-4A0A1	U21S02-COIL

TOYOTA トヨタ
 NISSAN 日産
 HONDA ホンダ
 MAZDA マツダ
 SUBARU スバル
 MITSUBISHI ミツビシ
 SUZUKI スズキ
 DAIHATSU ダイハツ
 ISUZU いすゞ
 純正品番順
 対照表-1
 Astemo品番順
 対照表-2

●印：生産終了品

品番対照表 (純正品番順)

トヨタ TOYOTA
日産 NISSAN
ホンダ HONDA
マツダ MAZDA
スバル SUBARU
三菱 MITSUBISHI
スズキ SUZUKI
ダイハツ DAIHATSU
いすゞ ISUZU
対照表-1 純正品番順
対照表-2 Astemo品番順

純正品番	Astemo品番
日産 NISSAN	
22448-4A0A2	U21S02-COIL (● U12S01-COIL)
22448-4M500	U08001-COIL
22448-4M50A	U08001-COIL
22448-4W001	● U09117-COIL
22448-4W011	● U09120-COIL
22448-5CA0A	U24N02-COIL
22448-5L300	U09108-COIL
22448-5TA0A	U20N02-COIL
22448-5TT0A	U20N02-COIL
22448-67U05	● U09107-COIL
22448-6J901	U08002-COIL
22448-6N000	U08101-COIL
22448-6N001	U08101-COIL
22448-6N011	U08101-COIL
22448-6N015	U08101-COIL
22448-6N200	U08102-COIL
22448-6N210	U08102-COIL
22448-6N215	U08102-COIL
22448-6P000	U09103-COIL
22448-6RC0C	U24N03-COIL
22448-7DA0A	U24N01-COIL
22448-8H300	U08103-COIL
22448-8H310	U08103-COIL
22448-8H314	U08103-COIL
22448-8H315	U08103-COIL
22448-8J110	U16N01-COIL
22448-8J111	U16N01-COIL
22448-8J115	U16N01-COIL
22448-8J11C	U16N01-COIL
22448-91F00	U09123-COIL
22448-9Y600	U08103-COIL
22448-AA000	U09110-COIL
22448-AA100	U09108-COIL
22448-AA101	U09108-COIL
22448-AD101	U09101-COIL (● U09102-COIL)
22448-AL500	U08104-COIL
22448-AL510	U08104-COIL
22448-AL515	U08104-COIL
22448-AL600	U08105-COIL
22448-AL610	U08105-COIL
22448-AL615	U08105-COIL
22448-AL61C	U08105-COIL
22448-AR000	U08106-COIL
22448-AR010	U08106-COIL
22448-AR015	U08106-COIL
22448-AR210	U08107-COIL
22448-AR215	U08107-COIL

純正品番	Astemo品番
日産 NISSAN	
22448-AX001	U08108-COIL
22448-ED000	U13N04-COIL
22448-ED800	U15N01-COIL
22448-ED80A	U15N01-COIL
22448-EN200	U13N04-COIL
22448-EY00A	U17N02-COIL
22448-F6513	● U09112-COIL
22448-HA00A	U18M01-COIL
22448-JA00C	U13N04-COIL
22448-JA10A	U16N02-COIL
22448-JA10C	U16N02-COIL
22448-JF00B	U18N02-COIL
22448-VT40A	● U13N02-COIL
22462-4A00A	U21S02-COIL (● U12S01-COIL)
22462-6A00A	U15C01-COIL
22462-6A00B	U15C02-COIL
22462-6A00C	U21C01-COIL
22462-6A00D	U19N02-COIL
22462-6A00E	U19N02-COIL
22462-6A0A0	U11C01-COIL
ホンダ HONDA	
30500-POA-A01	U12H02-COIL
30500-PCA-003	U12H02-COIL
30500-PE0-006	U12H09-COIL
30510-P73-A01	U12H01-COIL
30510-P73-A02	U12H01-COIL
30510-PT2-006	U12H01-COIL (● U12H06-COIL)
30520-58G-003	U20H01-COIL
30520-58G-013	U20H01-COIL
30520-59B-013	U16H07-COIL
30520-59B-023	U16H07-COIL
30520-5A2-A01	U22H02-COIL
30520-5A2-S01	U22H02-COIL
30520-5R0-003	U16H04-COIL
30520-5R0-013	U16H04-COIL
30520-5Z1-003	U16H05-COIL
30520-5Z1-013	U16H05-COIL
30520-5Z1-023	U16H05-COIL
30520-5Z2-003	U16H06-COIL
30520-5Z2-013	U16H06-COIL
30520-P8E-A01	U09001-COIL
30520-P8E-S01	U09001-COIL
30520-PCX-007	U14H01-COIL
30520-PFB-007	U09001-COIL
30520-PFE-004	U09001-COIL
30520-PGK-A01	U09001-COIL
30520-PNA-007	U14H01-COIL

●印：生産終了品

品番対照表 (純正品番順)

純正品番	Astemo品番
ホンダ HONDA	
30520-PNC-004	U14H01-COIL
30520-PPD-003	U09003-COIL
30520-PPD-S01	U09003-COIL
30520-PVF-A01	U09001-COIL
30520-PVJ-A01	U09001-COIL
30520-PWA-003	U09007-COIL
30520-PWA-S01	U09007-COIL
30520-PWC-003	U09008-COIL
30520-PWC-013	U09008-COIL
30520-PWC-S01	U09008-COIL
30520-PXH-004	U09001-COIL
30520-R40-007	U17H01-COIL
30520-R70-A01	U09002-COIL
30520-R70-S01	U09002-COIL
30520-R9G-004	U22H01-COIL
30520-RB0-003	U09005-COIL
30520-RB0-013	U09005-COIL
30520-RB0-S01	U09005-COIL
30520-RBJ-003	U09010-COIL
30520-RBJ-013	U09010-COIL
30520-RBJ-S01	U09010-COIL
30520-RCA-A01	U09001-COIL
30520-RCA-A02	U09001-COIL
30520-RCA-S01	U09001-COIL
30520-RGA-004	U09001-COIL
30520-RNA-A01	U20H03-COIL
30520-RNA-S01	U20H03-COIL
30520-RRA-007	U14H01-COIL
30520-RS8-004	U15H01-COIL
30520-RWC-A01	U14H01-COIL
30521-PWA-003	U09006-COIL
30521-PWA-S01	U09006-COIL
30521-RBJ-003	U09009-COIL
30521-RBJ-013	U09009-COIL
30521-RBJ-S01	U09009-COIL
30521-RLB-003	U09006-COIL
マツダ MAZDA	
1A03-18-100	U21S02-COIL (● U12S01-COIL)
1A03-18-100A	U21S02-COIL (● U12S01-COIL)
1A05-18-100	U21S02-COIL (● U12S01-COIL)
1A05-18-100A	U21S02-COIL (● U12S01-COIL)
1A06-18-100	U21S02-COIL (● U12S01-COIL)
1A07-18-100	U21S02-COIL (● U12S01-COIL)

純正品番	Astemo品番
マツダ MAZDA	
1A07-18-100A	U21S02-COIL (● U12S01-COIL)
1A08-18-100	U21S02-COIL (● U12S01-COIL)
1A09-18-100	U21S02-COIL (● U12S01-COIL)
1A10-18-100	U19S01-COIL
1A12-18-100	U21S02-COIL (● U12S01-COIL)
1A13-18-100	U19S01-COIL
1A14-18-100	U19S01-COIL
1A17-18-100	U22S02-COIL
1A51-18-100	U12S02-COIL
1A51-18-100A	U12S02-COIL
1A51-18-100B	U12S02-COIL
1N01-18-100	U08101-COIL
1N03-18-100	U08101-COIL
1N04-18-100	U08101-COIL
1N06-18-100	U08101-COIL
1N07-18-100	U08108-COIL
1N08-18-100	U13N04-COIL
1N11-18-100	U13N04-COIL
1N12-18-100	U13N04-COIL
B6S7-18-100	U23M01-COIL
FP85-18-100B	U15M02-COIL
FP85-18-100C	U15M02-COIL
L3G2-18-100A	U18M03-COIL
L3G2-18-100B	U18M03-COIL
L813-18-100	U12M01-COIL
LF16-18-100	U18M04-COIL
LF16-18-100B	U18M04-COIL
LF2L-18-100A	U18M01-COIL
LFB6-18-100C	U22M01-COIL
N3H1-18-100	U15M01-COIL
N3H1-18-100A	U15M01-COIL
N3H1-18-100B	U15M01-COIL
N3H1-18-100C	U15M01-COIL
P51R-18-100	U21M01-COIL
ZJ01-18-100	U17M01-COIL
ZJ01-18-100A	U17M01-COIL
ZJ20-18-100A	U19M02-COIL
スバル SUBARU	
19500-B2050	U18D04-COIL
19500-B2051	U18D04-COIL
22433AA430	U13F03-COIL
22433AA451	U13F01-COIL
22433AA480	U18F03-COIL
22433AA500	U15F01-COIL
22433AA540	U18F03-COIL

TOYOTA トヨタ
 NISSAN 日産
 HONDA ホンダ
 MAZDA マツダ
 SUBARU スバル
 MITSUBISHI 三菱
 SUZUKI スズキ
 DAIHATSU ダイハツ
 ISUZU いすゞ
 純正品番順
 対照表-1
 Astemo品番順
 対照表-2

●印：生産終了品

品番対照表 (純正品番順)

トヨタ	TOYOTA
日産	NISSAN
ホンダ	HONDA
マツダ	MAZDA
スバル	SUBARU
三菱	MITSUBISHI
スズキ	SUZUKI
ダイハツ	DAIHATSU
いすゞ	ISUZU
対照表-1	純正品番順
対照表-2	Astemo品番順

純正品番	Astemo品番
スバル SUBARU	
22433AA550	U13F01-COIL
22433AA551	U13F01-COIL
22433AA561	U18F02-COIL
22433AA580	U15F01-COIL
22433AA602	U20F03-COIL
22433AA621	U19F03-COIL
22433AA630	U22F01-COIL
22433AA640	U18F03-COIL
22433AA641	U18F03-COIL
22433AA682	U20F04-COIL
22433AA700	U19F01-COIL
22433AA730	U23T07-COIL
22433AA741	U20F01-COIL
22433AA781	U20F02-COIL
22433AA800	U21F01-COIL
22433AA840	U20F02-COIL
22433AA850	U21F01-COIL
22433KA470	U12F01-COIL
22433KA581	U13F02-COIL
22433KA610	U15F04-COIL
22433KA611	U15F04-COIL
22433KA612	U15F04-COIL
22433KA630	U15F04-COIL
22433KA631	U15F04-COIL
22433KA632	U15F04-COIL
22448-4M50A	U08001-COIL
22448-6N015	U08101-COIL
90919-02260	U13T04-COIL
三菱 MITSUBISHI	
1832A016	U18C02-COIL
1832A028	U20C02-COIL
1832A057	U19N02-COIL
1832A059	U21C01-COIL
1832A062	U21C03-COIL
1832A080	U19N02-COIL
MD308914	U12C04-COIL
MD314583	U15C03-COIL
MD315999	U13C01-COIL
MD321461	U12C03-COIL
MD325048	U11C02-COIL
MD325592	U15C01-COIL
MD338017	U13C01-COIL
MD344196	U11C03-COIL
MD346383	U11C01-COIL
MD346866	U11C03-COIL
MD353882	U11C03-COIL
MD354007	U11C03-COIL
MD358244	U11C03-COIL
MD360384	U11C02-COIL

純正品番	Astemo品番
三菱 MITSUBISHI	
MD362907	U11C02-COIL
MD362913	U11C03-COIL
MD363552	U12C03-COIL
MD366821	U11C03-COIL
MN115259	U15C02-COIL
MN195616	U21C02-COIL
MQ500763	U15S02-COIL
MQ509900	U22S01-COIL
MQ701132	U08108-COIL
MQ701133	U15N01-COIL
MQ701134	U13N04-COIL
MQ703889	U13N04-COIL
MQ712809	U15N01-COIL
MQ913543	U22M01-COIL
スズキ SUZUKI	
33400-50M00	U19S01-COIL
33400-50M10	U19S01-COIL
33400-50Z01	U13N04-COIL
33400-50Z02	U13N04-COIL
33400-51K00	U15S02-COIL
33400-51K20	U15S02-COIL
33400-51K40	U15S02-COIL
33400-51K41	U15S02-COIL
33400-52Z10	U20N02-COIL
33400-59S00	U21S01-COIL
33400-63R00	U22S02-COIL
33400-64P00	U19S01-COIL
33400-64P10	U19S01-COIL
33400-65G00	U12S03-COIL
33400-65G01	U12S03-COIL
33400-65G02	U12S03-COIL
33400-74P00	U19S02-COIL
33400-74P10	U19S02-COIL
33400-76G00	U21S02-COIL (●U12S01-COIL)
33400-76G01	U21S02-COIL (●U12S01-COIL)
33400-76G11	U21S02-COIL (●U12S01-COIL)
33400-76G20	U21S02-COIL (●U12S01-COIL)
33400-76G21	U21S02-COIL (●U12S01-COIL)
33400-76G30	U21S02-COIL (●U12S01-COIL)
33400-76S00	U24S01-COIL
33400-77R00	U19S06-COIL
33400-77R01	U19S06-COIL
33400-77R10	U19S06-COIL

●印：生産終了品

品番対照表 (純正品番順)

純正品番	Astemo品番
スズキ SUZUKI	
33400-78R00	U19S07-COIL
33400-78R01	U19S07-COIL
33400-78R10	U19S07-COIL
33400-81P00	U22S01-COIL
33400-85K00	U21S02-COIL (●U12S01-COIL)
33400-85K10	U21S02-COIL (●U12S01-COIL)
33400-85K20	U21S02-COIL (●U12S01-COIL)
33410-66D00	U12S04-COIL
33410-66D01	U12S04-COIL
33410-71G00	U13S01-COIL
33410-77E20	U12S02-COIL
33410-77E21	U12S02-COIL
33410-77E22	U12S02-COIL
ダイハツ DAIHATSU	
19070-97201-000	U15D06-COIL
19070-97203-000	U15D06-COIL
19070-97204-000	U15D01-COIL
19070-97205	U15D04-COIL
19070-97205-000	U15D04-COIL
19070-97206	U15D02-COIL
19070-97206-000	U15D02-COIL
19070-97207	U18D03-COIL
19070-97207-000	U18D03-COIL
19070-97501	U15D01-COIL
19070-97501-000	U15D01-COIL
19500-87101	U18D02-COIL
19500-87101-000	U18D02-COIL
19500-97201	U18D01-COIL
19500-B1010	U12D01-COIL
19500-B2010	U17D01-COIL
19500-B2030	U17D01-COIL
19500-B2040	U12D01-COIL
19500-B2050	U18D04-COIL
19500-B2051	U18D04-COIL
19500-B2060	U22D01-COIL
19500-B2070	U24D01-COIL
90048-52111-000	U11D01-COIL
90048-52117-000	U13D02-COIL
90048-52119-000	U13D01-COIL
90048-52125	U21D01-COIL
90048-52126	U21D01-COIL
90048-52126-000	U21D01-COIL
90048-52127-000	U11D02-COIL
90048-52130	U15D03-COIL
90048-52130-000	U15D03-COIL
90919-02135	U12T12-COIL

純正品番	Astemo品番
ダイハツ DAIHATSU	
90919-02135-000	U12T12-COIL
90919-02139	U12T13-COIL
90919-02139-000	U12T13-COIL
90919-02217	U12T18-COIL
90919-02218	U12T18-COIL
90919-02220	U12T18-COIL
90919-02237	U13T07-COIL
90919-02239	U13T05-COIL
90919-02243	U13T03-COIL
90919-02244	U13T03-COIL
90919-02248	U13T04-COIL
90919-02256	U13T06-COIL
90919-02258	U19T14-COIL
90919-02260	U13T04-COIL
90919-02262	U13T05-COIL
90919-02266	U13T03-COIL
90919-02281	U22T02-COIL
いすゞ ISUZU	
5-86141-317-0	U13N04-COIL
5-86153-966-0	U13N04-COIL

TOYOTA トヨタ
 NISSAN 日産
 HONDA ホンダ
 MAZDA マツダ
 SUBARU スバル
 MITSUBISHI 三菱
 SUZUKI スズキ
 DAIHATSU ダイハツ
 ISUZU いすゞ
 純正品番順 対照表-1
 Astemo品番順 対照表-2

●印：生産終了品

品番対照表 (Astemo 品番順)

トヨタ TOYOTA
日産 NISSAN
ホンダ HONDA
マツダ MAZDA
スバル SUBARU
三菱 MITSUBISHI
スズキ SUZUKI
ダイハツ DAIHATSU
いすゞ ISUZU
対照表-1 純正品番
対照表-2 Astemo品番順

Astemo品番	純正品番
トヨタ TOYOTA	
U12T01-COIL	90919-02164
U12T02-COIL	90919-02197
U12T12-COIL	90919-02135
U12T13-COIL	90919-02139
U12T14-COIL	90919-02163
U12T18-COIL	90919-02217
	90919-02218
	90919-02220
U13T01-COIL	90919-02229
	90919-02240
U13T02-COIL	90919-02230
U13T03-COIL	90919-02243
	90919-02244
	90919-02266
U13T04-COIL	90919-02247
	90919-02248
	90919-02260
	90919-C2002
	90919-C2006
	90919-T2005
U13T05-COIL	90919-02239
	90919-02262
U13T06-COIL	90919-02250
	90919-02256
	90919-C2004
U13T07-COIL	90919-02237
U13T08-COIL	90919-02265
U15D03-COIL	90048-52130
U18D02-COIL	19500-87101
	19500-B2050
U18D04-COIL	19500-B2051
	19500-B2051
U19T11-COIL	90919-02234
U19T14-COIL	90919-02258
U19T15-COIL	90919-02251
	90919-02255
U20T02-COIL	19070-B1011
U20T03-COIL	90919-02257
U21D01-COIL	90048-52126
U21T01-COIL	90919-02272
U21T04-COIL	19070-BZ031
U22T01-COIL	90919-02216
U22T02-COIL	90919-02281
U23T01-COIL	90919-02277
U23T02-COIL	90919-02276
U23T03-COIL	90919-02269
U23T04-COIL	90919-02270
U23T05-COIL	90919-02273
U23T06-COIL	90919-02271
U23T07-COIL	SU003-05259

Astemo品番	純正品番
トヨタ TOYOTA	
U24D01-COIL	19500-B2070
日産 NISSAN	
U08001-COIL	22448-4M500
	22448-4M50A
U08002-COIL	22448-6J901
U08101-COIL	22448-6N000
	22448-6N001
	22448-6N011
	22448-6N015
U08102-COIL	22448-6N200
	22448-6N210
	22448-6N215
U08103-COIL	22433-8H315
	22448-8H300
	22448-8H310
	22448-8H314
	22448-8H315
U08104-COIL	22448-9Y600
	22448-AL500
	22448-AL510
U08105-COIL	22448-AL515
	22433-AL61C
	22448-AL600
	22448-AL610
	22448-AL615
U08106-COIL	22448-AL61C
	22448-AR000
	22448-AR010
	22448-AR015
U08107-COIL	22448-AR210
	22448-AR215
U08108-COIL	22448-AX001
U09101-COIL	22448-31U00
	22448-31U01
	22448-31U11
U09101-COIL (● U09102-COIL)	22448-AD101
U09103-COIL	22448-3H000
	22448-6P000
● U09104-COIL	22433-25U00
U09105-COIL	22448-25U00
U09106-COIL	22448-31U05
	22448-31U06
	22448-31U16
● U09107-COIL	22448-67U05
U09108-COIL	22448-5L300
	22448-AA100
	22448-AA101

●印：生産終了品

品番対照表 (Astemo 品番順)

Astemo品番	純正品番
日産 NISSAN	
U09110-COIL	22433-AA000 22448-AA000
● U09111-COIL	22433-59S11 22433-59S12
● U09112-COIL	22448-F6513
U09113-COIL	22448-2Y502
U09114-COIL	22448-2Y700
U09115-COIL	22448-2Y000
● U09116-COIL	22448-2Y001
● U09117-COIL	22448-4W001
U09118-COIL	22448-2Y005
U09119-COIL	22448-2Y006 22448-2Y007
● U09120-COIL	22448-4W011
U09121-COIL	22433-60U01 22433-60U02
U09122-COIL	22448-02U10 22448-02U11
U09123-COIL	22448-91F00
U11C01-COIL	22462-6A0A0
● U13N02-COIL	22448-VT40A
U13N03-COIL	22448-3HDOA 22448-3HDOB 22448-3HDOC
U13N04-COIL	22448-1KTOA 22448-ED000 22448-EN200 22448-JA00C
U15C01-COIL	22462-6A00A
U15C02-COIL	22462-6A00B
U15N01-COIL	22448-ED800 22448-ED80A
U16N01-COIL	22433-8J11C 22448-8J110 22448-8J111 22448-8J115 22448-8J11C
U16N02-COIL	22448-JA10A 22448-JA10C
U17N01-COIL	22448-1KCOA
U17N02-COIL	22448-EY00A
U18N02-COIL	22448-JF00B
U18M01-COIL	22448-HA00A
U19N02-COIL	22462-6A00D 22462-6A00E
U19S01-COIL	22448-4A00G 22448-4A00H 22448-4A01A 22448-4A01B

Astemo品番	純正品番
日産 NISSAN	
U20N01-COIL	22448-1KTOB
U20N02-COIL	22448-5TA0A 22448-5TTOA
U21C01-COIL	22462-6A00C
U21S02-COIL	22448-4A0A0 22448-4A0A1
U21S02-COIL (● U12S01-COIL)	22448-4A00A 22448-4A00B 22448-4A00D 22448-4A00F 22448-4A0A2 22462-4A00A
U22M01-COIL	22433-HA001
U24N01-COIL	22448-7DA0A
U24N02-COIL	22448-5CA0A
U24N03-COIL	22448-6RC0C
ホンダ HONDA	
U09001-COIL	30520-P8E-A01 30520-P8E-S01 30520-PFB-007 30520-PFE-004 30520-PGK-A01 30520-PVF-A01 30520-PVJ-A01 30520-PXH-004 30520-RCA-A01 30520-RCA-A02 30520-RCA-S01 30520-RGA-004
U09002-COIL	30520-R70-A01 30520-R70-S01
U09003-COIL	30520-PPD-003 30520-PPD-S01
U09005-COIL	30520-RB0-003 30520-RB0-013 30520-RB0-S01
U09006-COIL	30521-PWA-003 30521-PWA-S01 30521-RLB-003
U09007-COIL	30520-PWA-003 30520-PWA-S01
U09008-COIL	30520-PWC-003 30520-PWC-013 30520-PWC-S01
U09009-COIL	30521-RBJ-003 30521-RBJ-013 30521-RBJ-S01

TOYOTA トヨタ
 NISSAN 日産
 HONDA ホンダ
 MAZDA マツダ
 SUBARU スバル
 MITSUBISHI 三菱
 SUZUKI スズキ
 DAIHATSU ダイハツ
 ISUZU いすゞ
 純正品番順
 対照表-1
 Astemo品番順
 対照表-2

●印：生産終了品

品番対照表 (Astemo 品番順)

トヨタ TOYOTA
日産 NISSAN
ホンダ HONDA
マツダ MAZDA
スバル SUBARU
三菱 MITSUBISHI
スズキ SUZUKI
ダイハツ DAIHATSU
いすゞ ISUZU
対照表-1 純正品番順
対照表-2 Astemo品番順

Astemo品番	純正品番
ホンダ HONDA	
U09010-COIL	30520-RBJ-003
	30520-RBJ-013
	30520-RBJ-S01
U12H01-COIL	30510-P73-A01
	30510-P73-A02
U12H01-COIL (● U12H06-COIL)	30510-PT2-006
U12H02-COIL	30500-POA-A01
	30500-PCA-003
U12H09-COIL	30500-PE0-006
U14H01-COIL	30520-PCX-007
	30520-PNA-007
	30520-PNC-004
	30520-RRA-007
U15H01-COIL	30520-RWC-A01
U15H01-COIL	30520-RS8-004
U16H04-COIL	30520-5R0-003
	30520-5R0-013
U16H05-COIL	30520-5Z1-003
	30520-5Z1-013
	30520-5Z1-023
U16H06-COIL	30520-5Z2-003
	30520-5Z2-013
U16H07-COIL	30520-59B-013
	30520-59B-023
U17H01-COIL	30520-R40-007
U20H01-COIL	30520-58G-003
	30520-58G-013
U20H03-COIL	30520-RNA-A01
	30520-RNA-S01
U22H01-COIL	30520-R9G-004
U22H02-COIL	30520-5A2-A01
	30520-5A2-S01
マツダ MAZDA	
U08101-COIL	1N01-18-100
	1N03-18-100
	1N04-18-100
	1N06-18-100
U08108-COIL	1N07-18-100
U12M01-COIL	L813-18-100
U12S02-COIL	1A51-18-100
	1A51-18-100A
	1A51-18-100B
U13N04-COIL	1N08-18-100
	1N11-18-100
	1N12-18-100

Astemo品番	純正品番
マツダ MAZDA	
U15M01-COIL	N3H1-18-100
	N3H1-18-100A
	N3H1-18-100B
	N3H1-18-100C
U15M02-COIL	FP85-18-100B
	FP85-18-100C
U17M01-COIL	ZJ01-18-100
	ZJ01-18-100A
U18M01-COIL	LF2L-18-100A
U18M03-COIL	L3G2-18-100A
	L3G2-18-100B
U18M04-COIL	LF16-18-100
	LF16-18-100B
U19M02-COIL	ZJ20-18-100A
U19S01-COIL	1A10-18-100
	1A13-18-100
	1A14-18-100
U21M01-COIL	P51R-18-100
U21S02-COIL (● U12S01-COIL)	1A03-18-100
	1A03-18-100A
	1A05-18-100
	1A05-18-100A
	1A06-18-100
	1A07-18-100
	1A07-18-100A
	1A08-18-100
1A09-18-100	
1A12-18-100	
U22M01-COIL	LFB6-18-100C
U22S02-COIL	1A17-18-100
U23M01-COIL	B6S7-18-100
スバル SUBARU	
U08001-COIL	22448-4M50A
U08101-COIL	22448-6N015
U12F01-COIL	22433KA470
	22433AA451
	22433AA550
	22433AA551
U13F02-COIL	22433KA581
U13F03-COIL	22433AA430
U13T04-COIL	90919-02260
U15F01-COIL	22433AA500
	22433AA580
U15F04-COIL	22433KA610
	22433KA611
	22433KA612
	22433KA630
	22433KA631
	22433KA632

●印：生産終了品

品番対照表 (Astemo 品番順)

Astemo品番	純正品番
スバル SUBARU	
U18F02-COIL	22433AA561
U18F03-COIL	22433AA480
	22433AA540
	22433AA640
	22433AA641
U18D04-COIL	19500-B2050
	19500-B2051
U19F01-COIL	22433AA700
U19F03-COIL	22433AA621
U20F01-COIL	22433AA741
U20F02-COIL	22433AA781
	22433AA840
U20F03-COIL	22433AA602
U20F04-COIL	22433AA682
U21F01-COIL	22433AA800
	22433AA850
U22F01-COIL	22433AA630
U23T07-COIL	22433AA730
三菱 MITSUBISHI	
U08108-COIL	MQ701132
U11C01-COIL	MD346383
U11C02-COIL	MD325048
	MD360384
	MD362907
U11C03-COIL	MD344196
	MD346866
	MD353882
	MD354007
	MD358244
	MD362913
	MD366821
U12C03-COIL	MD321461
	MD363552
U12C04-COIL	MD308914
U13C01-COIL	MD315999
	MD338017
U13N04-COIL	MQ701134
	MQ703889
U15C01-COIL	MD325592
U15C02-COIL	MN115259
U15C03-COIL	MD314583
U15N01-COIL	MQ701133
	MQ712809
U15S02-COIL	MQ500763
U18C02-COIL	1832A016
U19N02-COIL	1832A057
	1832A080
U20C02-COIL	1832A028
U21C01-COIL	1832A059

Astemo品番	純正品番
三菱 MITSUBISHI	
U21C02-COIL	MN195616
U21C03-COIL	1832A062
U22M01-COIL	MQ913543
U22S01-COIL	MQ509900
スズキ SUZUKI	
U12S02-COIL	33410-77E20
	33410-77E21
	33410-77E22
U12S03-COIL	33400-65G00
	33400-65G01
	33400-65G02
U12S04-COIL	33410-66D00
	33410-66D01
U13N04-COIL	33400-50Z01
	33400-50Z02
U13S01-COIL	33410-71G00
U15S02-COIL	33400-51K00
	33400-51K20
	33400-51K40
	33400-51K41
U19S01-COIL	33400-50M00
	33400-50M10
	33400-64P00
	33400-64P10
U19S02-COIL	33400-74P00
	33400-74P10
	33400-74P10
U19S06-COIL	33400-77R00
	33400-77R01
	33400-77R10
U19S07-COIL	33400-78R00
	33400-78R01
	33400-78R10
U20N02-COIL	33400-52Z10
U21S01-COIL	33400-59S00
U21S02-COIL (● U12S01-COIL)	33400-76G00
	33400-76G01
	33400-76G11
	33400-76G20
	33400-76G21
	33400-76G30
	33400-85K00
	33400-85K10
	33400-85K20
	33400-81P00
U22S01-COIL	33400-63R00
U22S02-COIL	33400-63R00
U24S01-COIL	33400-76S00
ダイハツ DAIHATSU	
U11D01-COIL	90048-52111-000
U11D02-COIL	90048-52127-000

TOYOTA トヨタ
 NISSAN 日産
 HONDA ホンダ
 MAZDA マツダ
 SUBARU スバル
 MITSUBISHI 三菱
 SUZUKI スズキ
 DAIHATSU ダイハツ
 ISUZU いすゞ
 純正品番順
 対照表-1
 Astemo品番順
 対照表-2

●印：生産終了品

品番対照表 (Astemo 品番順)

トヨタ
TOYOTA

日産
NISSAN

ホンダ
HONDA

マツダ
MAZDA

スバル
SUBARU

三菱
MITSUBISHI

スズキ
SUZUKI

ダイハツ
DAIHATSU

いすゞ
ISUZU

対照表-1
純正品番順

対照表-2
Astemo品番順

Astemo品番	純正品番
ダイハツ DAIHATSU	
U12D01-COIL	19500-B1010
	19500-B2040
U12T12-COIL	90919-02135
	90919-02135-000
U12T13-COIL	90919-02139
	90919-02139-000
U12T18-COIL	90919-02217
	90919-02218
	90919-02220
U13D01-COIL	90048-52119-000
U13D02-COIL	90048-52117-000
U13T03-COIL	90919-02243
	90919-02244
	90919-02266
U13T04-COIL	90919-02248
	90919-02260
U13T05-COIL	90919-02239
	90919-02262
U13T06-COIL	90919-02256
U13T07-COIL	90919-02237
U15D01-COIL	19070-97204-000
	19070-97501
	19070-97501-000
U15D02-COIL	19070-97206
	19070-97206-000
U15D03-COIL	90048-52130
	90048-52130-000
U15D04-COIL	19070-97205
	19070-97205-000
U15D06-COIL	19070-97201-000
	19070-97203-000
U17D01-COIL	19500-B2010
	19500-B2030
U18D01-COIL	19500-97201
U18D02-COIL	19500-87101
	19500-87101-000
U18D03-COIL	19070-97207
	19070-97207-000
U18D04-COIL	19500-B2050
	19500-B2051
U19T14-COIL	90919-02258
U21D01-COIL	90048-52125
	90048-52126
	90048-52126-000
U22D01-COIL	19500-B2060
U22T02-COIL	90919-02281
U24D01-COIL	19500-B2070

Astemo品番	純正品番
いすゞ ISUZU	
U13N04-COIL	5-86141-317-0
	5-86153-966-0

●印：生産終了品

Memo

A series of horizontal dashed lines for writing a memo.

Memo

A series of horizontal dashed lines spanning the width of the page, intended for writing a memo.

■ 販売元

Astemoアフターマーケットジャパン株式会社
Astemo Aftermarket Japan, Ltd.



FSC®認証材および管理原材料から作られた紙と
ノンVOCインキを使用し、印刷工程で廃液の出ない
「水なし印刷」を採用した環境配慮型印刷物です。